



CERTIFICATION OF TAX DEED APPLICATION

Sections 197.502 and 197.542, Florida Statutes

DR-513
Rule 12D-16.002 F.A.C
Effective 07/19
Page 1 of 2

0522.SA

Part 1: Tax Deed Application Information

Applicant Name Applicant Address	KEYS FUNDING LLC - 2019 US BANK CF KEYS FUNDING LLC - 2019 PO BOX 645040 CINCINNATI, OH 45264-5040	Application date	Apr 22, 2021
Property description	PALMER JIMMIE TROY 330 BUNKER HILL DR PENSACOLA, FL 32506 330 BUNKER HILL DR 09-4524-180 LT 26 BLK B LAKE CHARLENE PB 9 P 53 A B C D OR 7951 P 988 SEC 20/21 T2S R31W SEC 56 T2S R30W	Certificate #	2019 / 4832
		Date certificate issued	06/01/2019

Part 2: Certificates Owned by Applicant and Filed with Tax Deed Application

Column 1 Certificate Number	Column 2 Date of Certificate Sale	Column 3 Face Amount of Certificate	Column 4 Interest	Column 5: Total (Column 3 + Column 4)
# 2019/4832	06/01/2019	2,614.28	130.71	2,744.99
→Part 2: Total*				2,744.99

Part 3: Other Certificates Redeemed by Applicant (Other than County)

Column 1 Certificate Number	Column 2 Date of Other Certificate Sale	Column 3 Face Amount of Other Certificate	Column 4 Tax Collector's Fee	Column 5 Interest	Total (Column 3 + Column 4 + Column 5)
# 2020/5183	06/01/2020	2,678.32	6.25	133.92	2,818.49
Part 3: Total*					2,818.49

Part 4: Tax Collector Certified Amounts (Lines 1-7)

1. Cost of all certificates in applicant's possession and other certificates redeemed by applicant (*Total of Parts 2 + 3 above)	5,563.48
2. Delinquent taxes paid by the applicant	0.00
3. Current taxes paid by the applicant	0.00
4. Property information report fee	200.00
5. Tax deed application fee	175.00
6. Interest accrued by tax collector under s.197.542, F.S. (see Tax Collector Instructions, page 2)	0.00
7. Total Paid (Lines 1-6)	5,938.48

I certify the above information is true and the tax certificates, interest, property information report fee, and tax collector's fees have been paid, and that the property information statement is attached.

Sign here: Shirley Bish, CCA Escambia, Florida
 Signature, Tax Collector or Designee Date May 7th, 2021

Send this certification to the Clerk of Court by 10 days after the date signed. See Instructions on Page 2

Part 5: Clerk of Court Certified Amounts (Lines 8-14)	
8. Processing tax deed fee	
9. Certified or registered mail charge	
10. Clerk of Court advertising, notice for newspaper, and electronic auction fees	
11. Recording fee for certificate of notice	
12. Sheriff's fees	
13. Interest (see Clerk of Court Instructions, page 2)	
14. Total Paid (Lines 8-13)	
15. Plus one-half of the assessed value of homestead property, if applicable under s. 197.502(6)(c), F.S.	
16. Statutory opening bid (total of Lines 7, 14, 15, and 16 if applicable)	
Sign here: _____ Date of sale <u>05/02/2022</u>	
Signature, Clerk of Court or Designee	

INSTRUCTIONS

PLUS \$6.25

Tax Collector (complete Parts 1-4)

Part 2: Certificates Owned by Applicant and Filed with Tax Deed Application

Enter the Face Amount of Certificate in Column 3 and the Interest in Column 4 for each certificate number. Add Columns 3 and 4 and enter the amount in Column 5.

Part 3: Other Certificates Redeemed by Applicant (Other than County)

Total. Add the amounts in Columns 3, 4 and 5

Part 4: Tax Collector Certified Amounts (Lines 1-7)

Line 1, enter the total of Part 2 plus the total of Part 3 above.

Total Paid, Line 7: Add the amounts of Lines 1-6

Line 6, Interest accrued by tax collector. Calculate the 1.5 percent interest accrued from the month after the date of application through the month this form is certified to the clerk. Enter the amount to be certified to the clerk on **Line 6**. The interest calculated by the tax collector stops before the interest calculated by the clerk begins. See Section 197.542, F.S., and Rule 12D-13.060(3), Florida Administrative Code.

The tax collector's interest for redemption at the time of the tax deed application is a cost of redemption, which encompasses various percentages of interest on certificates and omitted or delinquent taxes under Section 197.502, F.S. This interest is calculated before the tax collector calculates the interest in Section 197.542, F.S.

Attach certified statement of names and addresses of persons who must be notified before the sale of the property. Send this form and any required attachments to the Clerk of Court within 10 days after it is signed.

Clerk of Court (complete Part 5)

Line 13: Interest is calculated at the rate of 1.5 percent per month starting from the first day of the month after the month of certification of this form through the last day of the month in which the sale will be held. Multiply the calculated rate by the total of **Line 7**, minus **Line 6**, plus **Lines 8** through **12**. Enter the amount on **Line 13**.

Line 14: Enter the total of Lines 8-13. Complete Lines 15-18, if applicable.

APPLICATION FOR TAX DEED

Section 197.502, Florida Statutes

512
R. 12/16

Application Number: 2100409

To: Tax Collector of ESCAMBIA COUNTY, Florida

I,
KEYS FUNDING LLC - 2019
US BANK CF KEYS FUNDING LLC - 2019
PO BOX 645040
CINCINNATI, OH 45264-5040,

hold the listed tax certificate and hereby surrender the same to the Tax Collector and make tax deed application thereon:

Account Number	Certificate No.	Date	Legal Description
09-4524-180	2019/4832	06-01-2019	LT 26 BLK B LAKE CHARLENE PB 9 P 53 A B C D OR 7951 P 988 SEC 20/21 T2S R31W SEC 56 T2S R30W

I agree to:

- pay any current taxes, if due and
- redeem all outstanding tax certificates plus interest not in my possession, and
- pay all delinquent and omitted taxes, plus interest covering the property.
- pay all Tax Collector's fees, property information report costs, Clerk of the Court costs, charges and fees, and Sheriff's costs, if applicable.

Attached is the tax sale certificate on which this application is based and all other certificates of the same legal description which are in my possession.

Electronic signature on file
KEYS FUNDING LLC - 2019
US BANK CF KEYS FUNDING LLC - 2019
PO BOX 645040
CINCINNATI, OH 45264-5040

04-22-2021
Application Date

Applicant's signature



Chris Jones Escambia County Property Appraiser

[Real Estate Search](#)

[Tangible Property Search](#)

[Sale List](#)

← Nav. Mode Account Parcel ID →

[Printer Friendly Version](#)

<p>General Information</p> <p>Parcel ID: 202S314110026002 Account: 094524180 Owners: HOGAN SHARON Mail: 6679 LAKE JOANNE DR PENSACOLA, FL 32506 Situs: 330 BUNKER HILL DR 32506 Use Code: SINGLE FAMILY RESID Taxing Authority: COUNTY MSTU Tax Inquiry: Open Tax Inquiry Window Tax Inquiry link courtesy of Scott Lunsford Escambia County Tax Collector</p>	<p>Assessments</p> <table border="1"> <thead> <tr> <th>Year</th> <th>Land</th> <th>Imprv</th> <th>Total</th> <th>Cap Val</th> </tr> </thead> <tbody> <tr> <td>2020</td> <td>\$38,000</td> <td>\$137,773</td> <td>\$175,773</td> <td>\$175,773</td> </tr> <tr> <td>2019</td> <td>\$38,000</td> <td>\$128,587</td> <td>\$166,587</td> <td>\$166,587</td> </tr> <tr> <td>2018</td> <td>\$38,000</td> <td>\$121,059</td> <td>\$159,059</td> <td>\$159,059</td> </tr> </tbody> </table> <p>Disclaimer</p> <p>Market Value Breakdown Letter</p> <p>Tax Estimator</p> <p>File for New Homestead Exemption Online</p> <p>Report Storm Damage</p>	Year	Land	Imprv	Total	Cap Val	2020	\$38,000	\$137,773	\$175,773	\$175,773	2019	\$38,000	\$128,587	\$166,587	\$166,587	2018	\$38,000	\$121,059	\$159,059	\$159,059																																		
Year	Land	Imprv	Total	Cap Val																																																			
2020	\$38,000	\$137,773	\$175,773	\$175,773																																																			
2019	\$38,000	\$128,587	\$166,587	\$166,587																																																			
2018	\$38,000	\$121,059	\$159,059	\$159,059																																																			
<p>Sales Data</p> <table border="1"> <thead> <tr> <th>Sale Date</th> <th>Book</th> <th>Page</th> <th>Value</th> <th>Type</th> <th>Official Records (New Window)</th> </tr> </thead> <tbody> <tr> <td>10/20/2020</td> <td>8387</td> <td>1945</td> <td>\$180,200</td> <td>CT</td> <td></td> </tr> <tr> <td>08/10/2018</td> <td>7951</td> <td>988</td> <td>\$189,900</td> <td>WD</td> <td></td> </tr> <tr> <td>05/29/2015</td> <td>7351</td> <td>1558</td> <td>\$100</td> <td>OT</td> <td></td> </tr> <tr> <td>11/26/2012</td> <td>6938</td> <td>1318</td> <td>\$100</td> <td>QC</td> <td></td> </tr> <tr> <td>04/2003</td> <td>5123</td> <td>1735</td> <td>\$100</td> <td>QC</td> <td></td> </tr> <tr> <td>03/2003</td> <td>5093</td> <td>681</td> <td>\$132,000</td> <td>WD</td> <td></td> </tr> <tr> <td>01/2001</td> <td>4650</td> <td>1800</td> <td>\$100</td> <td>WD</td> <td></td> </tr> <tr> <td>01/1976</td> <td>981</td> <td>889</td> <td>\$53,000</td> <td>WD</td> <td></td> </tr> </tbody> </table> <p>Official Records Inquiry courtesy of Pam Childers Escambia County Clerk of the Circuit Court and Comptroller</p>	Sale Date	Book	Page	Value	Type	Official Records (New Window)	10/20/2020	8387	1945	\$180,200	CT		08/10/2018	7951	988	\$189,900	WD		05/29/2015	7351	1558	\$100	OT		11/26/2012	6938	1318	\$100	QC		04/2003	5123	1735	\$100	QC		03/2003	5093	681	\$132,000	WD		01/2001	4650	1800	\$100	WD		01/1976	981	889	\$53,000	WD		<p>2020 Certified Roll Exemptions</p> <p>None</p> <p>Legal Description</p> <p>LT 26 BLK B LAKE CHARLENE PB 9 P 53 A B C D OR 8387 P 1945 SEC 20/21 T2S R31W SEC 56 T2S R30W</p> <p>Extra Features</p> <p>None</p>
Sale Date	Book	Page	Value	Type	Official Records (New Window)																																																		
10/20/2020	8387	1945	\$180,200	CT																																																			
08/10/2018	7951	988	\$189,900	WD																																																			
05/29/2015	7351	1558	\$100	OT																																																			
11/26/2012	6938	1318	\$100	QC																																																			
04/2003	5123	1735	\$100	QC																																																			
03/2003	5093	681	\$132,000	WD																																																			
01/2001	4650	1800	\$100	WD																																																			
01/1976	981	889	\$53,000	WD																																																			

<p>Parcel Information Launch Interactive Map</p> <p>Section</p> <p>Map Id: 20-2S-31-2</p> <p>Approx. Acreage: 0.3449</p> <p>Zoned: LDR</p> <p>Evacuation & Flood Information Open Report</p>
--

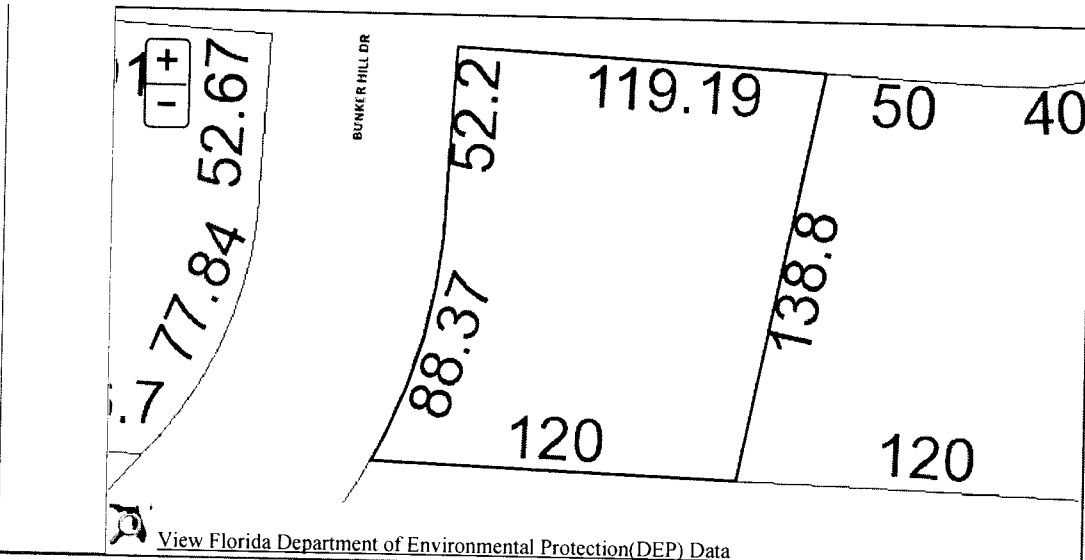

View Florida Department of Environmental Protection (DEP) Data

Buildings

Address: 330 BUNKER HILL DR, Year Built: 1976, Effective Year: 1976, PA Building ID#: 106183

- Structural Elements**
- DECOR/MILLWORK-ABOVE AVERAGE
 - DWELLING UNITS-1
 - EXTERIOR WALL-BRICK-FACE/VENEER
 - FLOOR COVER-CARPET
 - FOUNDATION-SLAB ON GRADE
 - HEAT/AIR-CENTRAL H/AC
 - INTERIOR WALL-DRYWALL-PLASTER
 - NO. PLUMBING FIXTURES-9
 - NO. STORIES-1
 - ROOF COVER-DIMEN/ARCH SHNG
 - ROOF FRAMING-GABLE
 - STORY HEIGHT-0
 - STRUCTURAL FRAME-WOOD FRAME

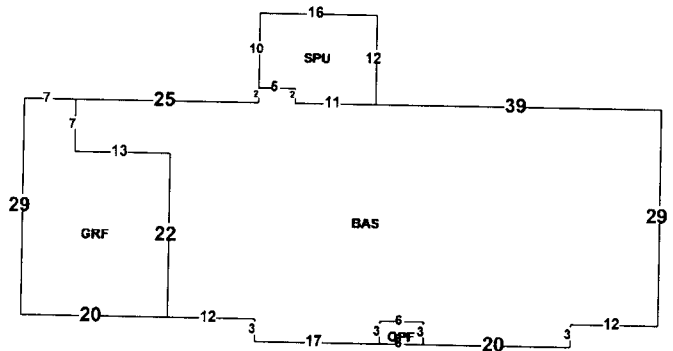

- Areas - 2862 Total SF**
- BASE AREA - 2173
 - GARAGE FIN - 489
 - OPEN PORCH FIN - 18
 - SCRN PORCH UNF - 182

Images



3/22/19

The primary use of the assessment data is for the preparation of the current year tax roll. No responsibility or liability is assumed for inaccuracies or errors.

PAM CHILDERS
 CLERK OF THE CIRCUIT COURT
 ARCHIVES AND RECORDS
 CHILDSUPPORT
 CIRCUIT CIVIL
 CIRCUIT CRIMINAL
 COUNTY CIVIL
 COUNTY CRIMINAL
 DOMESTIC RELATIONS
 FAMILY LAW
 JURY ASSEMBLY
 JUVENILE
 MENTAL HEALTH
 MIS
 OPERATIONAL SERVICES
 PROBATE
 TRAFFIC



BRANCH OFFICES
ARCHIVES AND RECORDS
JUVENILE DIVISION
CENTURY

CLERK TO THE BOARD OF
 COUNTY COMMISSIONERS
 OFFICIAL RECORDS
 COUNTY TREASURY
 AUDITOR

COUNTY OF ESCAMBIA
OFFICE OF THE
CLERK OF THE CIRCUIT COURT

PAM CHILDERS, CLERK OF THE CIRCUIT COURT
Tax Certificate Redeemed From Sale
Account: 094524180 Certificate Number: 004832 of 2019

Payor: SHARON M HOGAN 6979 LAKE JOANNE DR PENSACOLA FL 32506 Date 06/15/2021

Clerk's Check #	105914	Clerk's Total	\$558.07
Tax Collector Check #	1	Tax Collector's Total	\$7,402.73
		Postage	\$60.00
		Researcher Copies	\$0.00
		Recording	\$10.00
		Prep Fee	\$7.00
		Total Received	\$7,737.80

6283.89

\$16,300.89

PAM CHILDERS
 Clerk of the Circuit Court

Received By: _____
 Deputy Clerk

PAM CHILDERS
 CLERK OF THE CIRCUIT COURT
 ARCHIVES AND RECORDS
 CHILDSUPPORT
 CIRCUIT CIVIL
 CIRCUIT CRIMINAL
 COUNTY CIVIL
 COUNTY CRIMINAL
 DOMESTIC RELATIONS
 FAMILY LAW
 JURY ASSEMBLY
 JUVENILE
 MENTAL HEALTH
 MIS
 OPERATIONAL SERVICES
 PROBATE
 TRAFFIC



BRANCH OFFICES
ARCHIVES AND RECORDS
JUVENILE DIVISION
CENTURY

CLERK TO THE BOARD OF
 COUNTY COMMISSIONERS
 OFFICIAL RECORDS
 COUNTY TREASURY
 AUDITOR

COUNTY OF ESCAMBIA
OFFICE OF THE
CLERK OF THE CIRCUIT COURT

Case # 2019 TD 004832
Redeemed Date 06/15/2021

Name SHARON M HOGAN 6979 LAKE JOANNE DR PENSACOLA FL 32506

Clerk's Total = TAXDEED	\$ 558.07	6283.89
Due Tax Collector = TAXDEED	\$7,02.73	
Postage = TD2	\$60.00	
ResearcherCopies = TD6	\$0.00	
Release TDA Notice (Recording) = RECORD2	\$10.00	
Release TDA Notice (Prep Fee) = TD4	\$7.00	

• For Office Use Only

Date	Docket	Desc	Amount Owed	Amount Due	Payee Name
------	--------	------	-------------	------------	------------

No Information Available - See Dockets



**PAM CHILDERS
CLERK OF THE CIRCUIT COURT
ESCAMBIA COUNTY, FLORIDA**

Tax Deed - Redemption Calculator

Account: 094524180 Certificate Number: 004832 of 2019

Redemption No Application Date Interest Rate

	Final Redemption Payment ESTIMATED	Redemption Overpayment ACTUAL
	Auction Date <input type="text" value="05/02/2022"/>	Redemption Date <input type="text" value="06/15/2021"/>
Months	13	2
Tax Collector	<input type="text" value="\$5,938.48"/>	<input type="text" value="\$5,938.48"/>
Tax Collector Interest	\$1,158.00	\$178.15
Tax Collector Fee	<input type="text" value="\$6.25"/>	<input type="text" value="\$6.25"/>
Total Tax Collector	\$7,102.73	<input type="text" value="\$6,122.88"/> TC
Record TDA Notice	<input type="text" value="\$17.00"/>	<input type="text" value="\$17.00"/>
Clerk Fee	<input type="text" value="\$130.00"/>	<input type="text" value="\$130.00"/>
Sheriff Fee	<input type="text" value="\$120.00"/>	<input type="text" value="\$120.00"/>
Legal Advertisement	<input type="text" value="\$200.00"/>	<input type="text" value="\$200.00"/>
App. Fee Interest	\$91.07	\$14.01
Total Clerk	\$558.07	<input type="text" value="\$481.01"/> CH
Release TDA Notice (Recording)	<input type="text" value="\$10.00"/>	<input type="text" value="\$10.00"/>
Release TDA Notice (Prep Fee)	<input type="text" value="\$7.00"/>	<input type="text" value="\$7.00"/>
Postage	<input type="text" value="\$60.00"/>	<input type="text" value="\$0.00"/>
Researcher Copies	<input type="text" value="\$0.00"/>	<input type="text" value="\$0.00"/>
Total Redemption Amount	\$7,737.80	\$6,620.89
	Repayment Overpayment Refund Amount	\$1,116.91
Book/Page	<input type="text" value="8538"/>	<input type="text" value="7"/>

RELEASE OF NOTICE OF APPLICATION FOR TAX DEED

Pursuant to § 197.502(5)(c), Florida Statutes, the Escambia County Clerk of Court fully releases the Notice of Tax Deed Application recorded at Official Records Book 8538, Page 7, of Escambia County, for the tax certificate, tax deed, and property described below:

Tax Certificate No. Certificate No. 04832, issued the 1st day of June, A.D., 2019

TAX ACCOUNT NUMBER: 094524180 (0522-59)

DESCRIPTION OF PROPERTY:

LT 26 BLK B LAKE CHARLENE PB 9 P 53 A B C D OR 7951 P 988 SEC 20/21 T2S R31W SEC 56
T2S R30W

SECTION 20, TOWNSHIP 2 S, RANGE 31 W

NAME IN WHICH ASSESSED: JIMMIE TROY PALMER

Dated this 15th day of June 2021.

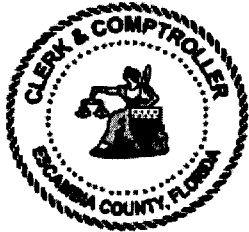

PAM CHILDERS
CLERK OF THE CIRCUIT COURT
ESCAMBIA COUNTY, FLORIDA

By:
Emily Hogg
Deputy Clerk

Pam Childers
CLERK OF THE CIRCUIT COURT
ESCAMBIA COUNTY FLORIDA
INST# 2021057564 5/25/2021 2:59 PM
OFF REC BK: 8538 PG: 7 Doc Type: TDN

NOTICE OF APPLICATION FOR TAX DEED

NOTICE IS HEREBY GIVEN, That **KEYS TAX FUNDING LLC – 19 US BANK** holder of **Tax Certificate No. 04832**, issued the **1st** day of **June, A.D., 2019** has filed same in my office and has made application for a tax deed to be issued thereon. Said certificate embraces the following described property in the County of Escambia, State of Florida, to wit:

LT 26 BLK B LAKE CHARLENE PB 9 P 53 A B C D OR 7951 P 988 SEC 20/21 T2S R31W SEC 56 T2S R30W

SECTION 20, TOWNSHIP 2 S, RANGE 31 W

TAX ACCOUNT NUMBER 094524180 (0522-59)

The assessment of the said property under the said certificate issued was in the name of

JIMMIE TROY PALMER

Unless said certificate shall be redeemed according to law, the property described therein will be sold to the highest bidder at public auction at 9:00 A.M. on the **first** Monday in the month of May, which is the **2nd day** of **May 2022**.

Dated this 25th day of May 2021.

In accordance with the AMERICANS WITH DISABILITIES ACT, if you are a person with a disability who needs special accommodation in order to participate in this proceeding you are entitled to the provision of certain assistance. Please contact Emily Hogg not later than seven days prior to the proceeding at Escambia County Government Complex, 221 Palafox Place Ste 110, Pensacola FL 32502. Telephone: 850-595-3793.



PAM CHILDERS
CLERK OF THE CIRCUIT COURT
ESCAMBIA COUNTY, FLORIDA

By:
Emily Hogg
Deputy Clerk



PROPERTY INFORMATION REPORT
3050 Concho Drive, Pensacola, Florida 32507 | Phone: 850-466-3077

THE ATTACHED REPORT IS ISSUED TO:

SCOTT LUNSFORD, ESCAMBIA COUNTY TAX COLLECTOR

TAX ACCOUNT #: 09-4524-180 CERTIFICATE #: 2019-4832

THIS REPORT IS NOT TITLE INSURANCE. THE LIABILITY FOR ERRORS OR OMISSIONS IN THIS REPORT IS LIMITED TO THE PERSON(S) EXPRESSLY IDENTIFIED BY NAME IN THE PROPERTY INFORMATION REPORT AS THE RECIPIENT(S) OF THE PROPERTY INFORMATION REPORT.

The attached Report prepared in accordance with the instructions given by the user named above includes a listing of the owner(s) of record of the land described herein together with current and delinquent ad valorem tax information and a listing and copies of all open or unsatisfied leases, mortgages, judgments and encumbrances recorded in the Official Record Books of Escambia County, Florida that appear to encumber the title to said land as listed on page 2 herein. It is the responsibility of the party named above to verify receipt of each document listed. If a copy of any document listed is not received, the office issuing this Report must be contacted immediately.

This Report is subject to: Current year taxes; taxes and assessments due now or in subsequent years; oil, gas, and mineral or any subsurface rights of any kind or nature; easements, restrictions and covenants of record; encroachments, overlaps, boundary line disputes, and any other matters that would be disclosed by an accurate survey and inspection of the premises.

This Report does not insure or guarantee the validity or sufficiency of any document attached, nor is it to be considered a title insurance policy, an opinion of title, a guarantee of title, or as any other form of guarantee or warranty of title.

Use of the term "Report" herein refers to the Property Information Report and the documents attached hereto.

Period Searched: February 17, 2002 to and including February 17, 2022 Abstractor: Cody Campbell

BY

Michael A. Campbell,
As President
Dated: February 28, 2022

PROPERTY INFORMATION REPORT
CONTINUATION PAGE

February 28, 2022

Tax Account #: **09-4524-180**

1. The Grantee(s) of the last deed(s) of record is/are: **SHARON HOGAN**

By Virtue of Certificate of Title recorded 10/21/2020 in OR 8387/1945 (add additional information/ abstractor's notes here or delete)

2. The land covered by this Report is: **See Attached Exhibit "A"**

3. The following unsatisfied mortgages, liens, and judgments affecting the land covered by this Report appear of record:

- a. **Civil Lien in favor of the State of FL/Escambia County recorded 1/7/2016 – OR 7461/63**

4. Taxes:

Taxes for the year(s) NONE are delinquent.

Tax Account #: 09-4524-180

Assessed Value: \$175,773.00

Exemptions: NONE

5. We find the following HOA names in our search (if a condominium, the condo docs book and page are included for your review): **LAKE CHARLENE HOMEOWNERS ASSOCIATION, INC.**

Payment of any special liens/assessments imposed by City, County, and/or State.

Note: Escambia County and/or local municipalities may impose special liens/assessments. These liens/assessments are not discovered in a title search or shown above. These special assessments typically create a lien on real property. The entity that governs subject property must be contacted to verify payment status.

PERDIDO TITLE & ABSTRACT, INC.
PROPERTY INFORMATION REPORT
3050 Concho Drive, Pensacola, Florida 32507 | Phone 850-466-3077

Scott Lunsford
Escambia County Tax Collector
P.O. Box 1312
Pensacola, FL 32591

CERTIFICATION: TITLE SEARCH FOR TDA

TAX DEED SALE DATE: _____ **MAY 2, 2022**

TAX ACCOUNT #: _____ **09-4524-180**

CERTIFICATE #: _____ **2019-4832**

In compliance with Section 197.522, Florida Statutes, the following is a list of names and addresses of those persons, firms, and/or agencies having legal interest in or claim against the above-described property. The above-referenced tax sale certificate is being submitted as proper notification of tax deed sale.

YES	NO	
<input type="checkbox"/>	<input type="checkbox"/>	Notify City of Pensacola, P.O. Box 12910, 32521
<input type="checkbox"/>	<input type="checkbox"/>	Notify Escambia County, 190 Governmental Center, 32502
<input type="checkbox"/>	<input type="checkbox"/>	Homestead for <u>2020</u> tax year.

**SHARON HOGAN AKA SHARON A. HOGAN
AKA SHARON ALLEN MARTIN HOGAN
AND JIMMIE TROY PALMER
300 BUNKER HILL DR
PENSACOLA, FL 32506**

**SHARON HOGAN AKA SHARON A. HOGAN
AKA SHARON ALLEN MARTIN HOGAN
6979 LAKE JOANNE DR
PENSACOLA, FL 32506**

**LAKE CHARLENE HOMEOWNERS ASSOCIATION, INC.
P.O. BOX 36277
PENSACOLA, FL 32516**

Certified and delivered to Escambia County Tax Collector, this 28th day of February, 2022.

PERDIDO TITLE & ABSTRACT, INC.



BY: Michael A. Campbell, As It's President

NOTE: The above listed addresses are based upon current information available, but addresses are not guaranteed to be true or correct.

PROPERTY INFORMATION REPORT

February 28, 2022

Tax Account #:09-4524-180

**LEGAL DESCRIPTION
EXHIBIT "A"**

**LT 26 BLK B LAKE CHARLENE PB 9 P 53 A B C D OR 7951 P 988 SEC 20/21 T2S R31W SEC 56 T2S
R30W**

SECTION 20, TOWNSHIP 2 S, RANGE 31 W

TAX ACCOUNT NUMBER 09-4524-180(0522-59)

Recorded in Public Records 10/21/2020 10:34 AM OR Book 8387 Page 1945,
Instrument #2020087701, Pam Childers Clerk of the Circuit Court Escambia
County, FL Deed Stamps \$1,261.40

**IN THE CIRCUIT COURT OF THE FIRST JUDICIAL CIRCUIT
IN AND FOR ESCAMBIA COUNTY, FLORIDA
CIVIL ACTION**

CASE NO. 2020 CA 000091

SHARON HOGAN AKA SHARON ALLEN MARTIN HOGAN
Plaintiff

VS.

PALMER, JIMMIE TROY ; UNKNOWN SPOUSE OF JIMMIE TROY PALMER ;
UNKNOWN PARTY IN POSSESSION 1 ; UNKNOWN PARTY IN POSSESSION 2
Defendant

CERTIFICATE OF TITLE

The undersigned, Pam Childers, Clerk of the Circuit Court, hereby certifies that a certificate of sale has been
executed and filed in this action on October 08, 2020, for the property described herein and that no objections to
the sale have been filed within the time allowed for filing objections.

The following property in Escambia County, Florida was sold to

HOGAN, SHARON
6979 Lake Joanne Drive PENSACOLA, FL, 32506

**Lot 26, Block "B", Lake Charlene, being a subdivision of a portion of Sections 20 and
21, Township 2 South, Range 31 West, and Section 56, Township 2 South, Range 30
West, Escambia County, Florida, as recorded in Plat Book 9, at Page 53, of the Public
Records of said County.**

The successful bid was in the amount of \$180200.00.

WITNESS my hand and the official seal on this 20 day of October, 2020, as Clerk of the Circuit Court.

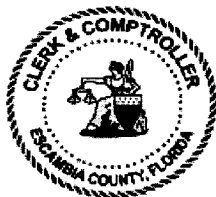

Pam Childers
Clerk of the Circuit Court

BY: *[Signature]*
Deputy Clerk

Conformed copies to all parties

IN THE COUNTY COURT IN AND FOR ESCAMBIA COUNTY, FLORIDA

STATE OF FLORIDA,

Plaintiff,

CASE NO: 2015-MM-006504-A

vs.

James Palmer

DIVISION: III

Defendant.

CIVIL LIEN

THIS CAUSE came before the Court for plea on **12/17/15**
Upon the evidence presented, the Court assessed **\$330.00 cost of supervision fee and \$50.00 Hearing Fee.** Therefore, the Court determines that **\$380.00** is due to **Department of Community Corrections**. Accordingly, pursuant to the provisions of §938.30, Florida Statutes, it is,

ORDERED AND ADJUDGED that the above-named Defendant shall pay arrears to the **Department of Community Corrections**, in the amount of **\$380.00** which shall accrue interest at the rate of four and seventy five percent (4.75%) per annum.

ORDERED FURTHER that nothing in this Civil Lien will bar any subsequent civil remedy or recovery, but the amount paid under this order shall be a set-off against any subsequent independent civil recovery. Any default in payment of the amount due hereunder may be collected by any means authorized by law for the enforcement of a civil judgment, for which let execution issue.

DONE AND ORDERED in Chambers, at Pensacola, Escambia County, Florida, the 31 day of Dec. 2015



Judge Thomas Dannheisser

cc: Community Corrections, Sue Mayo

FILED & RECORDED
2016 JAN -4 P 2:57
CLERK OF CIRCUIT COURT
ESCAMBIA COUNTY, FL

CERTIFIED TO BE A TRUE COPY OF THE ORIGINAL ON FILE IN THIS OFFICE
WITNESS MY HAND AND OFFICIAL SEAL
PAM CHILDERS
CLERK OF THE CIRCUIT COURT & COMPTROLLER
ESCAMBIA COUNTY, FLORIDA
BY Kaitlyn Bonam
DATE: 1/16/16

