

19-450

Tax Collector's Certification

CTY-513

Tax Deed Application Number
1900156

Date of Tax Deed Application
Apr 17, 2019

This is to certify that **CATALINA TAX CO LLC SERIES 17 US BANK % CATALINA TAX -SER 17**, holder of **Tax Sale Certificate Number 2017 / 1318**, Issued the 1st Day of June, 2017 and which encumbers the following described property in the county of Escambia County, State of Florida, to wit: **03-1986-012**

Cert Holder:
CATALINA TAX CO LLC SERIES 17 US BANK % CATALINA TAX -SER 17
PO BOX 645040
CINCINNATI, OH 45264-5040

Property Owner:
HARRIS JERNIGAN JR
6217 SARAH DR
PENSACOLA, FL 32503

LT 21 BLK 5 OAKFIELD ACRES PARCEL NO 6 PB 6 P 38 OR 7220 P
768 OR 7540 P 1544

has surrendered same in my office and made written application for tax deed in accordance with Florida Statutes. I certify that the following tax certificates, interest, ownership and encumbrance report fee, and Tax Collector's fees have been paid, or if the certificate is held by the County, all appropriate fees have been deposited.

Certificates owned by applicant and filed in connection with this application:

Certificate Year/Number	Account Number	Sale Date	Face Amount of Certificate	Interest	Total
2017/1318	03-1986-012	06/01/2017	1,744.61	87.23	1,831.84

Certificates redeemed by applicant or included (County) in connection with this tax deed application:

Certificate Year/Number	Account Number	Sale Date	Face Amount of Certificate	Tax Collector's Fee	Interest	Total
2018/1348	03-1986-012	06/01/2018	1,759.58	6.25	87.98	1,853.81

Amounts Certified by Tax Collector (Lines 1-7):**Total Amount Paid**

1. Total of all Certificates in Applicant's Possession and Cost of the Certificates Redeemed by Applicant	3,685.65
2. Total of Delinquent Taxes Paid by Tax Deed Applicant	0.00
3. Total of Current Taxes Paid by Tax Deed Applicant	1,629.65
4. Property Information Report Fee	200.00
5. Tax Deed Application Fee	175.00
6. Total Interest Accrued by Tax Collector Pursuant to Section 197.542, F.S.	
7. Total (Lines 1 - 6)	5,690.30

Amounts Certified by Clerk of Court (Lines 8-15):**Total Amount Paid**

8. Clerk of Court Statutory Fee for Processing Tax Deed	
9. Clerk of Court Certified Mail Charge	
10. Clerk of Court Advertising Charge	
11. Clerk of Court Recording Fee for Certificate of Notice	
12. Sheriff's Fee	
13. Interest Computed by Clerk of Court Pursuant to Section 197.542, F.S.	
14. Total (Lines 8 - 13)	
15. One-half Assessed Value of Homestead Property, if Applicable per F.S.	71,319.00
16. Other Outstanding Certificates and Delinquent Taxes Not Included in this Application,	
17. Statutory (Opening) Bid; Total of Lines 7, 14, 15 (if applicable) and 16 (if	
18. Redemption Fee	6.25
19. Total Amount to Redeem	

Done this the 24th day of April, 2019 Scott Lunsford, Tax Collector of Escambia County

Date of Sale: 9-3-19

By 

*This certification must be surrendered to the Clerk of the Circuit Court no later than ten (10) days after this date.
03-1986-012 2017

APPLICATION FOR TAX DEED

Section 197.502, Florida Statutes

512
R. 12/16

Application Number: 1900156

To: Tax Collector of ESCAMBIA COUNTY, Florida

I,
CATALINA TAX CO LLC SERIES 17 US BANK % CATALINA TAX -SER 17
PO BOX 645040
CINCINNATI, OH 45264-5040,

hold the listed tax certificate and hereby surrender the same to the Tax Collector and make tax deed application thereon:

Account Number	Certificate No.	Date	Legal Description
03-1986-012	2017/1318	06-01-2017	LT 21 BLK 5 OAKFIELD ACRES PARCEL NO 6 PB 6 P 38 OR 7220 P 768 OR 7540 P 1544

I agree to:

- pay any current taxes, if due and
- redeem all outstanding tax certificates plus interest not in my possession, and
- pay all delinquent and omitted taxes, plus interest covering the property.
- pay all Tax Collector's fees, property information report costs, Clerk of the Court costs, charges and fees, and Sheriff's costs, if applicable.

Attached is the tax sale certificate on which this application is based and all other certificates of the same legal description which are in my possession.

Electronic signature on file
CATALINA TAX CO LLC SERIES 17 US BANK %
CATALINA TAX -SER 17
PO BOX 645040
CINCINNATI, OH 45264-5040

04-17-2019
Application Date

Applicant's signature



Chris Jones
Escambia County Property Appraiser

Real Estate Search Tangible Property Search Sale List

[Back](#)

← Navigate Mode Account Reference →

[Printer Friendly Version](#)

<p>General Information</p> <p>Reference: 281S304200210005 Account: 031986012 Owners: HARRIS JERNIGAN JR Mail: 6217 SARAH DR PENSACOLA, FL 32503 Situs: 6217 SARAH DR 32503 Use Code: SINGLE FAMILY RESID Taxing Authority: COUNTY MSTU Tax Inquiry: Open Tax Inquiry Window Tax Inquiry link courtesy of Scott Lunsford Escambia County Tax Collector</p>	<p>Assessments</p> <table border="1"> <thead> <tr> <th>Year</th> <th>Land</th> <th>Imprv</th> <th>Total</th> <th>Cap Val</th> </tr> </thead> <tbody> <tr> <td>2018</td> <td>\$22,800</td> <td>\$131,524</td> <td>\$154,324</td> <td>\$142,638</td> </tr> <tr> <td>2017</td> <td>\$22,800</td> <td>\$121,810</td> <td>\$144,610</td> <td>\$139,705</td> </tr> <tr> <td>2016</td> <td>\$22,800</td> <td>\$117,964</td> <td>\$140,764</td> <td>\$136,832</td> </tr> </tbody> </table> <p style="text-align: center;">Disclaimer</p> <p style="text-align: center;">Tax Estimator</p> <p style="text-align: center;">> File for New Homestead Exemption Online</p>	Year	Land	Imprv	Total	Cap Val	2018	\$22,800	\$131,524	\$154,324	\$142,638	2017	\$22,800	\$121,810	\$144,610	\$139,705	2016	\$22,800	\$117,964	\$140,764	\$136,832
Year	Land	Imprv	Total	Cap Val																	
2018	\$22,800	\$131,524	\$154,324	\$142,638																	
2017	\$22,800	\$121,810	\$144,610	\$139,705																	
2016	\$22,800	\$117,964	\$140,764	\$136,832																	

<p>Sales Data</p> <table border="1"> <thead> <tr> <th>Sale Date</th> <th>Book</th> <th>Page</th> <th>Value</th> <th>Type</th> <th>Official Records (New Window)</th> </tr> </thead> <tbody> <tr> <td>06/14/2016</td> <td>7540</td> <td>1544</td> <td>\$100</td> <td>QC</td> <td>View Instr</td> </tr> <tr> <td>10/25/2013</td> <td>7220</td> <td>768</td> <td>\$100</td> <td>QC</td> <td>View Instr</td> </tr> </tbody> </table> <p>Official Records Inquiry courtesy of Pam Childers Escambia County Clerk of the Circuit Court and Comptroller</p>	Sale Date	Book	Page	Value	Type	Official Records (New Window)	06/14/2016	7540	1544	\$100	QC	View Instr	10/25/2013	7220	768	\$100	QC	View Instr	<p>2018 Certified Roll Exemptions HOMESTEAD EXEMPTION</p> <p>Legal Description LT 21 BLK 5 OAKFIELD ACRES PARCEL NO 6 PB 6 P 38 OR 7220 P 768 OR 7540 P 1544</p> <p>Extra Features None</p>
Sale Date	Book	Page	Value	Type	Official Records (New Window)														
06/14/2016	7540	1544	\$100	QC	View Instr														
10/25/2013	7220	768	\$100	QC	View Instr														

Parcel Information [Launch Interactive Map](#)

Section Map Id: 28-15-30

Approx. Acreage: 0.3455

Zoned: MDR

Evacuation & Flood Information
[Open Report](#)

[View Florida Department of Environmental Protection\(DEP\) Data](#)

Buildings	
Address:6217 SARAH DR, Year Built: 1975, Effective Year: 1975	
<p>Structural Elements</p> <p>DECOR/MILLWORK-AVERAGE DWELLING UNITS-1 EXTERIOR WALL-BRICK-FACE/VENEER FLOOR COVER-CARPET FOUNDATION-SLAB ON GRADE HEAT/AIR-CENTRAL H/AC INTERIOR WALL-DRYWALL-PLASTER NO. PLUMBING FIXTURES-8 NO. STORIES-2</p>	

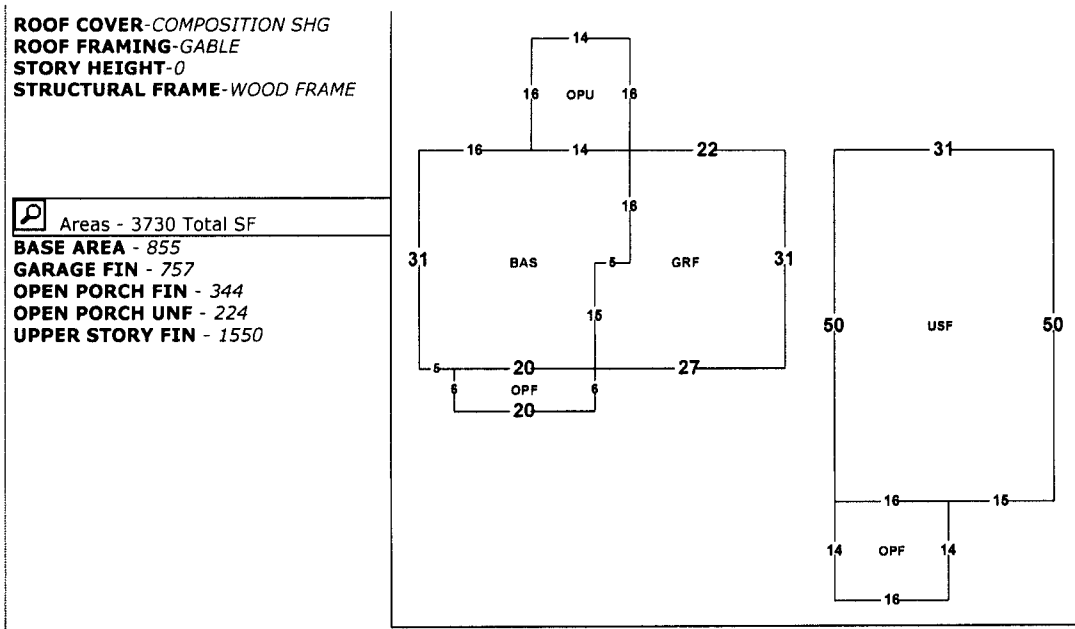

Images



2/21/19

The primary use of the assessment data is for the preparation of the current year tax roll. No responsibility or liability is assumed for inaccuracies or errors.

Last Updated: 04/25/2019 (tc.27218)

NOTICE OF APPLICATION FOR TAX DEED

NOTICE IS HEREBY GIVEN, That **CATALINA TAX CO LLC SERIES 17 US BANK** holder of **Tax Certificate No. 01318**, issued the **1st** day of **June, A.D., 2017** has filed same in my office and has made application for a tax deed to be issued thereon. Said certificate embraces the following described property in the County of Escambia, State of Florida, to wit:

LT 21 BLK 5 OAKFIELD ACRES PARCEL NO 6 PB 6 P 38 OR 7220 P 768 OR 7540 P 1544

SECTION 28, TOWNSHIP 1 S, RANGE 30 W

TAX ACCOUNT NUMBER 031986012 (19-450)

The assessment of the said property under the said certificate issued was in the name of

JERNIGAN HARRIS JR

Unless said certificate shall be redeemed according to law, the property described therein will be sold to the highest bidder at public auction at 9:00 A.M. on the **first** Tuesday in the month of September, which is the **3rd day of September 2019**.

Dated this 29th day of April 2019.

In accordance with the AMERICANS WITH DISABILITIES ACT, if you are a person with a disability who needs special accommodation in order to participate in this proceeding you are entitled to the provision of certain assistance. Please contact Emily Hogg not later than seven days prior to the proceeding at Escambia County Government Complex, 221 Palafox Place Ste 110, Pensacola FL 32502. Telephone: 850-595-3793.



PAM CHILDERS
CLERK OF THE CIRCUIT COURT
ESCAMBIA COUNTY, FLORIDA

By:
Emily Hogg
Deputy Clerk

19-450

Southern Guaranty Title Company

4400 Bayou Boulevard, Suite 13B
Pensacola, Florida 32503
Telephone: 850-478-8121
Facsimile: 850-476-1437

PROPERTY INFORMATION REPORT

File No.: 15204

June 4, 2019

Escambia County Tax Collector
P.O. Box 1312
Pensacola, Florida 32591

Pursuant to your request, the Company has caused a search to be made of the Public Records of Escambia County, Florida, solely as revealed by records maintained from 06-04-1999, through 06-04-2019, and said search reveals the following:

1. THE GRANTEE(S) OF THE LAST DEED(S) OF RECORD IS:

Jernigan Harris, Jr.

2. The land covered by this Report is:

LEGAL DESCRIPTION IS ATTACHED HERETO AND MADE A PART HEREOF

3. The following unsatisfied mortgages, liens and judgments affecting the land covered by this Report appear of record:

SEE CONTINUATION PAGE ATTACHED HERETO AND MADE A PART HEREOF

4. Taxes:

SEE CONTINUATION PAGE ATTACHED HERETO AND MADE A PART HEREOF

This report is not title insurance. Pursuant to s. 627.7843, Florida Statutes, the maximum liability of the issuer of this property information report for errors or omissions in this property information report is limited to the amount paid for this property information report, and is further limited to the person(s) expressly identified by name in the property information report as the recipients(s) of the property information report.

THIS REPORT SHALL NOT BE USED FOR THE ISSUANCE OF TITLE INSURANCE.

Southern Guaranty Title Company

By: 

June 4, 2019

**PROPERTY INFORMATION REPORT
LEGAL DESCRIPTION**

File No.: 15204

June 4, 2019

Lot 21, Block 5, Oakfield Acres Parcel Number 6, as per plat thereof, recorded in Plat Book 6, Page 38, of the Public Records of Escambia County, Florida

**PROPERTY INFORMATION REPORT
CONTINUATION PAGE**

File No.: 15204

June 4, 2019

UNSATISFIED MORTGAGES, LIENS AND JUDGMENTS AFFECTING THE LAND COVERED BY THIS REPORT THAT APPEAR OF RECORD:

1. Taxes for the year 2016-2018 delinquent. The assessed value is \$154,324.00. Tax ID 03-1986-012.

PLEASE NOTE THE FOLLOWING:

- A. Subject to current year taxes.
- B. Taxes and assessments due now or in subsequent years.
- C. Subject to Easements, Restrictions and Covenants of record.
- D. Encroachments, overlaps, boundary line disputes, and any other matters which would be disclosed by an accurate survey and inspection of the premises.
- E. Oil, gas and mineral or any other subsurface rights of any kind or nature.

SOUTHERN GUARANTY TITLE COMPANY

4400 BAYOU BLVD., SUITE 13-B, CORDOVA SQUARE

PENSACOLA, FLORIDA 32503

TEL. (850) 478-8121 FAX (850) 476-1437

Email: rcsgt@aol.com

Scott Lunsford
Escambia County Tax Collector
P.O. Box 1312
Pensacola, FL 32591

CERTIFICATION: TITLE SEARCH FOR TDA

TAX DEED SALE DATE: 9-3-2019

TAX ACCOUNT NO.: 03-1986-012

CERTIFICATE NO.: 2017-1318

In compliance with Section 197.256, Florida Statutes, the following is a list of names and addresses of those persons, firms and/or agencies having legal interest in or claim against the above described property. The above referenced tax sale certificate is being submitted as proper notification of tax deed sale.

YES NO

 X Notify City of Pensacola, P.O. Box 12910, 32521

 X Notify Escambia County, 190 Governmental Center, 32502

 X Homestead for 2018 tax year.

Jernigan Harris, Jr.
6217 Sarah Dr.
Pensacola, FL 32503

Certified and delivered to Escambia County Tax Collector,
this 4th day of June, 2019.

SOUTHERN GUARANTY TITLE COMPANY

by: Richard S. Combs, President

NOTE: The above listed addresses are based upon current information available, but said addresses are not guaranteed to be true or correct.

Prepared by:
Jernigan Harris, Jr.
6217 Sarah Dr.
Pensacola, Fl. 32503
Tax Number 281S304200210005

CORRECTIVE QUIT CLAIM DEED

Wherever used herein, the term "party" shall include the heirs, personal representatives, successors and/or assigns of the respective parties hereto; the use of the singular number shall include the plural, and the plural the singular; the use of any gender shall include all genders; and, if used, the term "note" shall include all the notes herein described if more than one.

MADE THIS 14th day of June, 2016, to correct the signature line for Jernigan Harris, Sr. on the Quit Claim Deed recorded in OR Book 7220, Page 768 of the public records of Escambia County, Florida, BETWEEN Vernester A. Harris and Jernigan Harris, Sr., wife and husband, 6324 Antietam Drive, Pensacola, Fl. 32503, Escambia County, Florida (Grantor) and Jernigan Harris, Jr., 6217 Sarah Drive, Pensacola, Fl. 32503, Escambia County, Florida (Grantee).

The said Grantor, for and in consideration of the sum of Ten and 00/100 Dollars, paid by the said Grantee, the receipt of which is hereby acknowledged, has remised, released and quitclaimed, and by these presents does remise, release, and quitclaim unto the said Grantee all the right, title, interest, claim and demand which the said Grantor has in and to the following described property, situate lying and being in the County of Escambia, State of Florida, to-wit:

Lot 21, Block 5, of Oakfield Acres Parcel Number 6, according to plat thereof recorded in Plat Book 6, Page 38, of the Public Records of Escambia County, Florida.

TO HAVE AND TO HOLD the same, together with all and singular the appurtenances thereunto belonging or in anywise appertaining, and all the estate, right, title, interest and claim whatsoever of the said Grantor, either in law or equity, to the only proper use, benefit and behoove of the said Grantee.

IN WITNESS WHEREOF, the said party of the first part has hereunto set his hand and seal on the day and year first above written.

Vernester A. Harris
Vernester A. Harris

Jernigan Harris, Sr. by Vernester A. Harris
Vernester A. Harris as his attorney-in-fact
Jernigan Harris, Sr., by Vernester A. Harris as his attorney-in-fact

Signed, sealed and delivered in the presence of:

Witness #1 Sign: [Signature]
Witness #1 Print Name: M. A. [Signature]

Witness #2 Sign: [Signature]
Witness #2 Print Name: JENNIFER GANTT

STATE OF Florida
COUNTY OF Escambia

THE FOREGOING INSTRUMENT was acknowledged before me this 14th day of June, 2016, by Vernester A. Harris and Jernigan Harris, Sr. by Vernester A. Harris as his attorney-in-fact, wife and husband, having provided DRIVERS LICENSE as identification, and who did take an oath.

My Commission expires:
(Notary Stamp or Seal)

[Signature]
Notary Public

Notary Public - State of FL
Comm. Exp. June 2, 2018
Comm. No. FF 162362

STATE OF FLORIDA
COUNTY OF ESCAMBIA

**CERTIFICATE OF NOTICE OF MAILING
NOTICE OF APPLICATION FOR TAX DEED**

CERTIFICATE # 01318 of 2017

I, PAM CHILDERS, CLERK OF THE CIRCUIT COURT OF ESCAMBIA COUNTY, FLORIDA, do hereby certify that I did on July 18, 2019, mail a copy of the foregoing Notice of Application for Tax Deed, addressed to:

JERNIGAN HARRIS JR
6217 SARAH DR
PENSACOLA, FL 32503

WITNESS my official seal this 18th day of July 2019.



PAM CHILDERS
CLERK OF THE CIRCUIT COURT
ESCAMBIA COUNTY, FLORIDA

By:
Emily Hogg
Deputy Clerk

WARNING

THERE ARE UNPAID TAXES ON PROPERTY WHICH YOU OWN OR IN WHICH YOU HAVE A LEGAL INTEREST. THE PROPERTY WILL BE SOLD AT PUBLIC AUCTION ON September 3, 2019, UNLESS THE TAXES ARE PAID. SHOULD YOU NEED FURTHER INFORMATION CONTACT THE CLERK OF THE CIRCUIT COURT IMMEDIATELY AT THE COUNTY COURTHOUSE IN PENSACOLA, FLORIDA, OR CALL 850-595-3793.

NOTICE OF APPLICATION FOR TAX DEED

NOTICE IS HEREBY GIVEN, That CATALINA TAX CO LLC SERIES 17 US BANK holder of Tax Certificate No. 01318, issued the 1st day of June, A.D., 2017 has filed same in my office and has made application for a tax deed to be issued thereon. Said certificate embraces the following described property in the County of Escambia, State of Florida, to wit:

LT 21 BLK 5 OAKFIELD ACRES PARCEL NO 6 PB 6 P 38 OR 7220 P 768 OR 7540 P 1544

SECTION 28, TOWNSHIP 1 S, RANGE 30 W

TAX ACCOUNT NUMBER 031986012 (19-450)

The assessment of the said property under the said certificate issued was in the name of

JERNIGAN HARRIS JR

Unless said certificate shall be redeemed according to law, the property described therein will be sold to the highest bidder at public auction at 9:00 A.M. on the first Tuesday in the month of September, which is the 3rd day of September 2019.

Dated this 15th day of July 2019.

In accordance with the AMERICANS WITH DISABILITIES ACT, if you are a person with a disability who needs special accommodation in order to participate in this proceeding you are entitled to the provision of certain assistance. Please contact Emily Hogg not later than seven days prior to the proceeding at Escambia County Government Complex, 221 Palafox Place Ste 110, Pensacola FL 32502. Telephone: 850-595-3793.

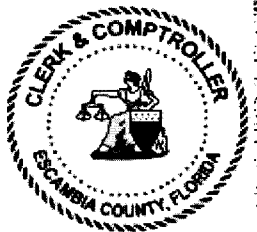

PAM CHILDERS
CLERK OF THE CIRCUIT COURT
ESCAMBIA COUNTY, FLORIDA

By:
Emily Hogg
Deputy Clerk

WARNING

THERE ARE UNPAID TAXES ON PROPERTY WHICH YOU OWN OR IN WHICH YOU HAVE A LEGAL INTEREST. THE PROPERTY WILL BE SOLD AT PUBLIC AUCTION ON September 3, 2019, UNLESS THE TAXES ARE PAID. SHOULD YOU NEED FURTHER INFORMATION CONTACT THE CLERK OF THE CIRCUIT COURT IMMEDIATELY AT THE COUNTY COURTHOUSE IN PENSACOLA, FLORIDA, OR CALL 850-595-3793.

NOTICE OF APPLICATION FOR TAX DEED

NOTICE IS HEREBY GIVEN, That CATALINA TAX CO LLC SERIES 17 US BANK holder of Tax Certificate No. 01318, issued the 1st day of June, A.D., 2017 has filed same in my office and has made application for a tax deed to be issued thereon. Said certificate embraces the following described property in the County of Escambia, State of Florida, to wit:

LT 21 BLK 5 OAKFIELD ACRES PARCEL NO 6 PB 6 P 38 OR 7220 P 768 OR 7540 P 1544

SECTION 28, TOWNSHIP 1 S, RANGE 30 W

TAX ACCOUNT NUMBER 031986012 (19-450)

The assessment of the said property under the said certificate issued was in the name of

JERNIGAN HARRIS JR

Unless said certificate shall be redeemed according to law, the property described therein will be sold to the highest bidder at public auction at 9:00 A.M. on the first Tuesday in the month of September, which is the 3rd day of September 2019.

Dated this 15th day of July 2019.

In accordance with the AMERICANS WITH DISABILITIES ACT, if you are a person with a disability who needs special accommodation in order to participate in this proceeding you are entitled to the provision of certain assistance. Please contact Emily Hogg not later than seven days prior to the proceeding at Escambia County Government Complex, 221 Palafox Place Ste 110, Pensacola FL 32502. Telephone: 850-595-3793.

Post Property:

6217 SARAH DR 32503



PAM CHILDERS
CLERK OF THE CIRCUIT COURT
ESCAMBIA COUNTY, FLORIDA

By:
Emily Hogg
Deputy Clerk

WARNING

THERE ARE UNPAID TAXES ON PROPERTY WHICH YOU OWN OR IN WHICH YOU HAVE A LEGAL INTEREST. THE PROPERTY WILL BE SOLD AT PUBLIC AUCTION ON September 3, 2019, UNLESS THE TAXES ARE PAID. SHOULD YOU NEED FURTHER INFORMATION CONTACT THE CLERK OF THE CIRCUIT COURT IMMEDIATELY AT THE COUNTY COURTHOUSE IN PENSACOLA, FLORIDA, OR CALL 850-595-3793.

NOTICE OF APPLICATION FOR TAX DEED

NOTICE IS HEREBY GIVEN, That CATALINA TAX CO LLC SERIES 17 US BANK holder of Tax Certificate No. 01318, issued the 1st day of June, A.D., 2017 has filed same in my office and has made application for a tax deed to be issued thereon. Said certificate embraces the following described property in the County of Escambia, State of Florida, to wit:

LT 21 BLK 5 OAKFIELD ACRES PARCEL NO 6 PB 6 P 38 OR 7220 P 768 OR 7540 P 1544

SECTION 28, TOWNSHIP 1 S, RANGE 30 W

TAX ACCOUNT NUMBER 031986012 (19-450)

The assessment of the said property under the said certificate issued was in the name of

JERNIGAN HARRIS JR

Unless said certificate shall be redeemed according to law, the property described therein will be sold to the highest bidder at public auction at 9:00 A.M. on the first Tuesday in the month of September, which is the 3rd day of September 2019.

Dated this 15th day of July 2019.

In accordance with the AMERICANS WITH DISABILITIES ACT, if you are a person with a disability who needs special accommodation in order to participate in this proceeding you are entitled to the provision of certain assistance. Please contact Emily Hogg not later than seven days prior to the proceeding at Escambia County Government Complex, 221 Palafox Place Ste 110, Pensacola FL 32502. Telephone: 850-595-3793.

Personal Services:

JERNIGAN HARRIS JR
6217 SARAH DR
PENSACOLA, FL 32503

PAM CHILDERS
CLERK OF THE CIRCUIT COURT
ESCAMBIA COUNTY, FLORIDA



By:
Emily Hogg
Deputy Clerk

ESCAMBIA COUNTY SHERIFF'S OFFICE
ESCAMBIA COUNTY, FLORIDA

19-450

NON-ENFORCEABLE RETURN OF SERVICE

Document Number: ECSO19CIV032907NON

Agency Number: 19-010036

Court: TAX DEED

County: ESCAMBIA

Case Number: CERT NO 01318 2017

Attorney/Agent:

PAM CHILDERS
CLERK OF COURT
TAX DEED

Plaintiff: RE: JERNIGAN HARRIS JR

Defendant:

Type of Process: NOTICE OF APPLICATION FOR TAX DEED

Received this Writ on 7/18/2019 at 7:27 AM and served same at 10:50 AM on 7/19/2019 in ESCAMBIA COUNTY, FLORIDA, by serving POST PROPERTY , the within named, to wit: , .

POSTED TO PROPERTY PER CLERKS OFFICE INSTRUCTIONS

DAVID MORGAN, SHERIFF
ESCAMBIA COUNTY, FLORIDA

By: _____



T. ANTHONY, CPS

Service Fee: \$40.00

Receipt No: BILL

Printed By: KMJACKSON

WARNING

THERE ARE UNPAID TAXES ON PROPERTY WHICH YOU OWN OR IN WHICH YOU HAVE A LEGAL INTEREST. THE PROPERTY WILL BE SOLD AT PUBLIC AUCTION ON September 3, 2019, UNLESS THE TAXES ARE PAID. SHOULD YOU NEED FURTHER INFORMATION CONTACT THE CLERK OF THE CIRCUIT COURT IMMEDIATELY AT THE COUNTY COURTHOUSE IN PENSACOLA, FLORIDA, OR CALL 850-595-3793.

NOTICE OF APPLICATION FOR TAX DEED

NOTICE IS HEREBY GIVEN, That **CATALINA TAX CO LLC SERIES 17 US BANK** holder of **Tax Certificate No. 01318**, issued the **1st day of June, A.D., 2017** has filed same in my office and has made application for a tax deed to be issued thereon. Said certificate embraces the following described property in the County of Escambia, State of Florida, to wit:

LT 21 BLK 5 OAKFIELD ACRES PARCEL NO 6 PB 6 P 38 OR 7220 P 768 OR 7540 P 1544

SECTION 28, TOWNSHIP 1 S, RANGE 30 W

TAX ACCOUNT NUMBER 031986012 (19-450)

The assessment of the said property under the said certificate issued was in the name of

JERNIGAN HARRIS JR

Unless said certificate shall be redeemed according to law, the property described therein will be sold to the highest bidder at public auction at 9:00 A.M. on the **first Tuesday** in the month of **September**, which is the **3rd day of September 2019**.

Dated this 15th day of July 2019.

In accordance with the AMERICANS WITH DISABILITIES ACT, if you are a person with a disability who needs special accommodation in order to participate in this proceeding you are entitled to the provision of certain assistance. Please contact Emily Hogg not later than seven days prior to the proceeding at Escambia County Government Complex, 221 Palafox Place Ste 110, Pensacola FL 32502. Telephone: 850-595-3793.

Post Property:

6217 SARAH DR 32503



PAM CHILDERS
CLERK OF THE CIRCUIT COURT
ESCAMBIA COUNTY, FLORIDA

By:
Emily Hogg
Deputy Clerk

ESCAMBIA COUNTY SHERIFF'S OFFICE
ESCAMBIA COUNTY, FLORIDA

19-450

NON-ENFORCEABLE RETURN OF SERVICE

Document Number: ECSO19CIV032911NON

Agency Number: 19-010037

Court: TAX DEED

County: ESCAMBIA

Case Number: CERT NO 01318 2017

Attorney/Agent:

PAM CHILDERS
CLERK OF COURT
TAX DEED

Plaintiff: RE: JERNIGAN HARRIS JR

Defendant:

Type of Process: NOTICE OF APPLICATION FOR TAX DEED

Non-Executed

Received this Writ on 7/18/2019 at 7:27 AM and after a diligent search in ESCAMBIA COUNTY, FLORIDA for JERNIGAN HARRIS JR , Writ was returned to court UNEXECUTED on 8/12/2019 for the following reason:

PER BROTHER AT 6217 SARAH DRIVE, SUBJECT DOES NOT LIVE HERE AND CURRENT ADDRESS IS UNKNOWN.
NO ADDITIONAL INFORMATION GAINED THROUGH DUE DILIGENCE EFFORTS.

DAVID MORGAN, SHERIFF
ESCAMBIA COUNTY, FLORIDA

By: _____

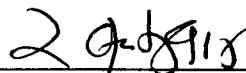

T. ANTHONY, CPS

Service Fee: \$40.00

Receipt No: BILL

Printed By: KMJACKSON

WARNING

THERE ARE UNPAID TAXES ON PROPERTY WHICH YOU OWN OR IN WHICH YOU HAVE A LEGAL INTEREST. THE PROPERTY WILL BE SOLD AT PUBLIC AUCTION ON September 3, 2019, UNLESS THE TAXES ARE PAID. SHOULD YOU NEED FURTHER INFORMATION CONTACT THE CLERK OF THE CIRCUIT COURT IMMEDIATELY AT THE COUNTY COURTHOUSE IN PENSACOLA, FLORIDA, OR CALL 850-595-3793.

NOTICE OF APPLICATION FOR TAX DEED

NOTICE IS HEREBY GIVEN, That CATALINA TAX CO LLC SERIES 17 US BANK holder of Tax Certificate No. 01318, issued the 1st day of June, A.D., 2017 has filed same in my office and has made application for a tax deed to be issued thereon. Said certificate embraces the following described property in the County of Escambia, State of Florida, to wit:

LT 21 BLK 5 OAKFIELD ACRES PARCEL NO 6 PB 6 P 38 OR 7220 P 768 OR 7540 P 1544

SECTION 28, TOWNSHIP 1 S, RANGE 30 W

TAX ACCOUNT NUMBER 031986012 (19-450)

The assessment of the said property under the said certificate issued was in the name of

JERNIGAN HARRIS JR

Unless said certificate shall be redeemed according to law, the property described therein will be sold to the highest bidder at public auction at 9:00 A.M. on the first Tuesday in the month of September, which is the 3rd day of September 2019.

Dated this 15th day of July 2019.

In accordance with the AMERICANS WITH DISABILITIES ACT, if you are a person with a disability who needs special accommodation in order to participate in this proceeding you are entitled to the provision of certain assistance. Please contact Emily Hogg not later than seven days prior to the proceeding at Escambia County Government Complex, 221 Palafox Place Ste 110, Pensacola FL 32502. Telephone: 850-595-3793.

Personal Services:

JERNIGAN HARRIS JR
6217 SARAH DR
PENSACOLA, FL 32503

PAM CHILDERS
CLERK OF THE CIRCUIT COURT
ESCAMBIA COUNTY, FLORIDA



By:
Emily Hogg
Deputy Clerk

WARNING

THERE ARE UNPAID TAXES ON PROPERTY WHICH YOU OWN OR IN WHICH YOU HAVE A LEGAL INTEREST. THE PROPERTY WILL BE SOLD AT PUBLIC AUCTION ON September 3, 2019, UNLESS THE TAXES ARE PAID. SHOULD YOU NEED FURTHER INFORMATION CONTACT THE CLERK OF THE CIRCUIT COURT IMMEDIATELY AT THE COUNTY COURTHOUSE IN PENSACOLA, FLORIDA, OR CALL 850-595-3793.

NOTICE OF APPLICATION FOR TAX DEED

NOTICE IS HEREBY GIVEN, That CATALINA TAX CO LLC SERIES 17 US BANK holder of Tax Certificate No. 01318, issued the 1st day of June, A.D., 2017 has filed same in my office and has made application for a tax deed to be issued thereon. Said certificate embraces the following described property in the County of Escambia, State of Florida, to wit:

LT 21 BLK 5 OAKFIELD ACRES PARCEL NO 6 PB 6 P 38 OR 7220 P 768 OR 7540 P 1544

SECTION 28, TOWNSHIP 1 S, RANGE 30 W

TAX ACCOUNT NUMBER 031986012 (19-450)

The assessment of the said property under the said certificate issued was in the name of

JERNIGAN HARRIS JR

Unless said certificate shall be redeemed according to law, the property described therein will be sold to the highest bidder at public auction at 9:00 A.M. on the first Tuesday in the month of September, which is the 3rd day of September 2019.

Dated this 15th day of July 2019.

In accordance with the AMERICANS WITH DISABILITIES ACT, if you are a person with a disability who needs special accommodation in order to participate in this proceeding you are entitled to the provision of certain assistance. Please contact Emily Hogg not later than seven days prior to the proceeding at Escambia County Government Complex, 221 Palafox Place Ste 110, Pensacola FL 32502. Telephone: 850-595-3793.

Personal Services:

JERNIGAN HARRIS JR
6217 SARAH DR
PENSACOLA, FL 32503

PAM CHILDERS
CLERK OF THE CIRCUIT COURT
ESCAMBIA COUNTY, FLORIDA



By:
Emily Hogg
Deputy Clerk

PAM CHILDERS
 CLERK OF THE CIRCUIT COURT
 ARCHIVES AND RECORDS
 CHILDSUPPORT
 CIRCUIT CIVIL
 CIRCUIT CRIMINAL
 COUNTY CIVIL
 COUNTY CRIMINAL
 DOMESTIC RELATIONS
 FAMILY LAW
 JURY ASSEMBLY
 JUVENILE
 MENTAL HEALTH
 MIS
 OPERATIONAL SERVICES
 PROBATE
 TRAFFIC



BRANCH OFFICES
ARCHIVES AND RECORDS
JUVENILE DIVISION
CENTURY

CLERK TO THE BOARD OF
 COUNTY COMMISSIONERS
 OFFICIAL RECORDS
 COUNTY TREASURY
 AUDITOR

COUNTY OF ESCAMBIA
OFFICE OF THE
CLERK OF THE CIRCUIT COURT

PAM CHILDERS, CLERK OF THE CIRCUIT COURT
Tax Certificate Redeemed From Sale
Account: 031986012 Certificate Number: 001318 of 2017

Payor: JERNIGAN AND GRACE M HARRIS 6217 SARAH DR PENSACOLA, FL 32503 **Date**
 08/26/2019

Clerk's Check #	2871513	Clerk's Total	\$502.03 6492.99
Tax Collector Check #	1	Tax Collector's Total	\$6,123.32
		Postage	\$5.60
		Researcher Copies	\$1.00
		Recording	\$10.00
		Prep Fee	\$7.00
		Total Received	\$6,648.95

\$ 6516.59

PAM CHILDERS
 Clerk of the Circuit Court

Received By: _____
 Deputy Clerk

PAM CHILDERS
 CLERK OF THE CIRCUIT COURT
 ARCHIVES AND RECORDS
 CHILDSUPPORT
 CIRCUIT CIVIL
 CIRCUIT CRIMINAL
 COUNTY CIVIL
 COUNTY CRIMINAL
 DOMESTIC RELATIONS
 FAMILY LAW
 JURY ASSEMBLY
 JUVENILE
 MENTAL HEALTH
 MIS
 OPERATIONAL SERVICES
 PROBATE
 TRAFFIC



BRANCH OFFICES
ARCHIVES AND RECORDS
JUVENILE DIVISION
CENTURY

CLERK TO THE BOARD OF
 COUNTY COMMISSIONERS
 OFFICIAL RECORDS
 COUNTY TREASURY
 AUDITOR

COUNTY OF ESCAMBIA
OFFICE OF THE
CLERK OF THE CIRCUIT COURT

Case # 2017 TD 001318
Redeemed Date 08/26/2019

Name JERNIGAN AND GRACE M HARRIS 6217 SARAH DR PENSACOLA, FL 32503

Clerk's Total = TAXDEED	\$ 502.03 6492.99
Due Tax Collector = TAXDEED	\$6,123.32
Postage = TD2	\$5.60
ResearcherCopies = TD6	\$1.00
Release TDA Notice (Recording) = RECORD2	\$10.00
Release TDA Notice (Prep Fee) = TD4	\$7.00

• For Office Use Only

Date	Docket	Desc	Amount Owed	Amount Due	Payee Name
------	--------	------	-------------	------------	------------

FINANCIAL SUMMARY

No Information Available - See Dockets

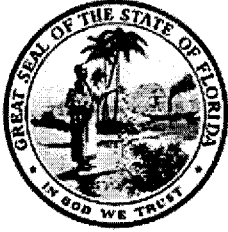

PAM CHILDERS
CLERK OF THE CIRCUIT COURT
ESCAMBIA COUNTY, FLORIDA

Tax Deed - Redemption Calculator

Account: 031986012 Certificate Number: 001318 of 2017

Redemption No Application Date Interest Rate

	Final Redemption Payment ESTIMATED	Redemption Overpayment ACTUAL
	Auction Date <input type="text" value="09/03/2019"/>	Redemption Date <input type="text" value="08/26/2019"/>
Months	5	4
Tax Collector	<input type="text" value="\$5,690.30"/>	<input type="text" value="\$5,690.30"/>
Tax Collector Interest	\$426.77	\$341.42
Tax Collector Fee	<input type="text" value="\$6.25"/>	<input type="text" value="\$6.25"/>
Total Tax Collector	\$6,123.32	<u>\$6,037.97</u> <i>JTC</i>
Record TDA Notice	<input type="text" value="\$17.00"/>	<input type="text" value="\$17.00"/>
Clerk Fee	<input type="text" value="\$130.00"/>	<input type="text" value="\$130.00"/>
Sheriff Fee	<input type="text" value="\$120.00"/>	<input type="text" value="\$120.00"/>
Legal Advertisement	<input type="text" value="\$200.00"/>	<input type="text" value="\$200.00"/>
App. Fee Interest	\$35.03	\$28.02
Total Clerk	\$502.03	<u>\$495.02</u> <i>CH</i>
Release TDA Notice (Recording)	<input type="text" value="\$10.00"/>	<input type="text" value="\$10.00"/>
Release TDA Notice (Prep Fee)	<input type="text" value="\$7.00"/>	<input type="text" value="\$7.00"/>
Postage	<input type="text" value="\$5.60"/>	<input type="text" value="\$5.60"/>
Researcher Copies	<input type="text" value="\$1.00"/>	<input type="text" value="\$1.00"/>
Total Redemption Amount	\$6,648.95	\$6,556.59
	Repayment Overpayment Refund Amount	\$92.36
Book/Page	<input type="text" value="8086"/>	<input type="text" value="579"/>

Notes

RELEASE OF NOTICE OF APPLICATION FOR TAX DEED

Pursuant to § 197.502(5)(c), Florida Statutes, the Escambia County Clerk of Court fully releases the Notice of Tax Deed Application recorded at Official Records Book 8086, Page 579, of Escambia County, for the tax certificate, tax deed, and property described below:

Tax Certificate No. Certificate No. 01318, issued the 1st day of June, A.D., 2017

TAX ACCOUNT NUMBER: 031986012 (19-450)

DESCRIPTION OF PROPERTY:

LT 21 BLK 5 OAKFIELD ACRES PARCEL NO 6 PB 6 P 38 OR 7220 P 768 OR 7540 P 1544

SECTION 28, TOWNSHIP 1 S, RANGE 30 W

NAME IN WHICH ASSESSED: JERNIGAN HARRIS JR

Dated this 26th day of August 2019.



PAM CHILDERS
CLERK OF THE CIRCUIT COURT
ESCAMBIA COUNTY, FLORIDA

By:
Emily Hogg
Deputy Clerk

JERNIGAN HARRIS JR [19-450]
6217 SARAH DR
PENSACOLA, FL 32503

9171 9690 0935 0128 2830 16

Contact ✓
owner



Escambia
Sun Press
 PUBLISHED WEEKLY SINCE 1948
 (Warrington) Pensacola, Escambia County, Florida

STATE OF FLORIDA
 County of Escambia

Before the undersigned authority personally appeared Michael P. Driver who is personally known to me and who on oath says that he is Publisher of The Escambia Sun Press, a weekly newspaper published at (Warrington) Pensacola in Escambia County, Florida; that the attached copy of advertisement, being a

NOTICE in the matter of SALE

SALE DATE - 09-03-2019 - TAX CERTIFICATE # 01318

in the CIRCUIT Court

was published in said newspaper in the issues of

AUGUST 1, 8, 15 & 22, 2019

Affiant further says that the said Escambia Sun-Press is a newspaper published at (Warrington) Pensacola, in said Escambia County, Florida, and that the said newspaper has heretofore been continuously published in said Escambia County, Florida each week and has been entered as second class mail matter at the post office in Pensacola, in said Escambia County, Florida, for a period of one year next preceding the first publication of the attached copy of advertisement; and affiant further says that he has neither paid nor promised any person, firm or corporation any discount, rebate, commission or refund for the purpose of securing this advertisement for publication in the said newspaper.

PUBLISHER

Sworn to and subscribed before me this 22ND day of AUGUST
 A.D., 2019

PAULA D. TURNER
 NOTARY PUBLIC

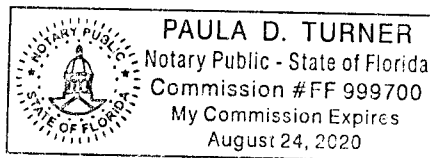

**NOTICE OF APPLICATION FOR
 TAX DEED**

NOTICE IS HEREBY GIVEN, That CATALINA TAX CO LLC SERIES 17 US BANK holder of Tax Certificate No. 01318, issued the 1st day of June, A.D., 2017 has filed same in my office and has made application for a tax deed to be issued thereon. Said certificate embraces the following described property in the County of Escambia, State of Florida, to wit:

LT 21 BLK 5 OAKFIELD ACRES PARCEL NO 6 PB 6 P 38 OR 7220 P 768 OR 7540 P 1544 SECTION 28, TOWNSHIP 1 S, RANGE 30 W

TAX ACCOUNT NUMBER 031986012 (19-450)

The assessment of the said property under the said certificate issued was in the name of JERNIGAN HARRIS JR

Unless said certificate shall be redeemed according to law, the property described therein will be sold to the highest bidder at public auction at 9:00 A.M. on the first Tuesday in the month of September, which is the 3rd day of September 2019.

Dated this 18th day of July 2019.

In accordance with the AMERICANS WITH DISABILITIES ACT, if you are a person with a disability who needs special accommodation in order to participate in this proceeding you are entitled to the provision of certain assistance. Please contact Emily Hogg not later than seven days prior to the proceeding at Escambia County Government Complex, 221 Palafox Place Ste 110, Pensacola FL 32502. Telephone: 850-595-3793.

PAM CHILDERS
 CLERK OF THE CIRCUIT COURT
 ESCAMBIA COUNTY, FLORIDA

By:
 Emily Hogg
 Deputy Clerk

oaw-4w-08-01-08-15-22-2019

JERNIGAN HARRIS JR [19-450]
6217 SARAH DR
PENSACOLA, FL 32503

9171 9690 0935 0128 2830 16

Contact ✓
owner