



# CERTIFICATION OF TAX DEED APPLICATION

Sections 197.502 and 197.542, Florida Statutes

DR-513  
Rule 12D-16.002 F.A.C  
Effective 07/19  
Page 1 of 2

0125.28

(H)

### Part 1: Tax Deed Application Information

Applicant Name Applicant Address	JUAN C CAPOTE MIKON FINANCIAL SERVICES, INC. AND OCEAN BANK 780 NW 42 AVE #204 MIAMI, FL 33126	Application date	Apr 17, 2024
Property description	SCOTT DALTON ALAN BOYD SCOTT VAN ALAN 3 NORWOOD DR PENSACOLA, FL 32506 3 NORWOOD DR 07-1794-000 LT 5 BLK 7 1ST ADDN TO PEN HAVEN PB 3 P 14 OR 7934 P 1144 CA 173	Certificate #	2022 / 3175
		Date certificate issued	06/01/2022

### Part 2: Certificates Owned by Applicant and Filed with Tax Deed Application

Column 1 Certificate Number	Column 2 Date of Certificate Sale	Column 3 Face Amount of Certificate	Column 4 Interest	Column 5: Total (Column 3 + Column 4)
# 2022/3175	06/01/2022	1,400.48	70.02	1,470.50
<b>→Part 2: Total*</b>				<b>1,470.50</b>

### Part 3: Other Certificates Redeemed by Applicant (Other than County)

Column 1 Certificate Number	Column 2 Date of Other Certificate Sale	Column 3 Face Amount of Other Certificate	Column 4 Tax Collector's Fee	Column 5 Interest	Total (Column 3 + Column 4 + Column 5)
# 2023/3186	06/01/2023	1,080.17	6.25	69.31	1,155.73
<b>Part 3: Total*</b>					<b>1,155.73</b>

### Part 4: Tax Collector Certified Amounts (Lines 1-7)

1. Cost of all certificates in applicant's possession and other certificates redeemed by applicant (*Total of Parts 2 + 3 above)	2,626.23
2. Delinquent taxes paid by the applicant	0.00
3. Current taxes paid by the applicant	1,012.45
4. Property information report fee	200.00
5. Tax deed application fee	175.00
6. Interest accrued by tax collector under s.197.542, F.S. (see Tax Collector Instructions, page 2)	0.00
7. <b>Total Paid (Lines 1-6)</b>	<b>4,013.68</b>

I certify the above information is true and the tax certificates, interest, property information report fee, and tax collector's fees have been paid, and that the property information statement is attached.

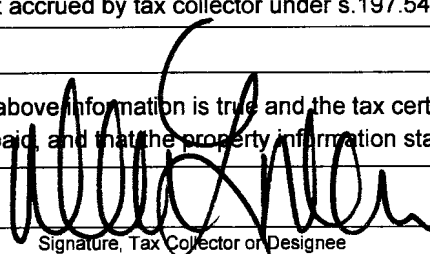
Sign here:   
Signature, Tax Collector or Designee

Escambia, Florida  
Date April 25th, 2024

Send this certification to the Clerk of Court by 10 days after the date signed. See Instructions on Page 2

+6.25

<b>Part 5: Clerk of Court Certified Amounts (Lines 8-14)</b>	
8. Processing tax deed fee	
9. Certified or registered mail charge	
10. Clerk of Court advertising, notice for newspaper, and electronic auction fees	
11. Recording fee for certificate of notice	
12. Sheriff's fees	
13. Interest (see Clerk of Court Instructions, page 2)	
14. <b>Total Paid (Lines 8-13)</b>	
15. Plus one-half of the assessed value of homestead property, if applicable under s. 197.502(6)(c), F.S.	52,480.50
16. Statutory opening bid (total of Lines 7, 14, 15, and 16 if applicable)	
Sign here: _____ Date of sale <u>01/08/2025</u>	
Signature, Clerk of Court or Designee	

**INSTRUCTIONS**

**Tax Collector (complete Parts 1-4)**

**Part 2: Certificates Owned by Applicant and Filed with Tax Deed Application**

Enter the Face Amount of Certificate in Column 3 and the Interest in Column 4 for each certificate number. Add Columns 3 and 4 and enter the amount in Column 5.

**Part 3: Other Certificates Redeemed by Applicant (Other than County)**

**Total.** Add the amounts in Columns 3, 4 and 5

**Part 4: Tax Collector Certified Amounts (Lines 1-7)**

**Line 1,** enter the total of Part 2 plus the total of Part 3 above.

**Total Paid, Line 7:** Add the amounts of Lines 1-6

**Line 6, Interest accrued by tax collector.** Calculate the 1.5 percent interest accrued from the month after the date of application through the month this form is certified to the clerk. Enter the amount to be certified to the clerk on **Line 6**. The interest calculated by the tax collector stops before the interest calculated by the clerk begins. See Section 197.542, F.S., and Rule 12D-13.060(3), Florida Administrative Code.

The tax collector's interest for redemption at the time of the tax deed application is a cost of redemption, which encompasses various percentages of interest on certificates and omitted or delinquent taxes under Section 197.502, F.S. This interest is calculated before the tax collector calculates the interest in Section 197.542, F.S.

Attach certified statement of names and addresses of persons who must be notified before the sale of the property. Send this form and any required attachments to the Clerk of Court within 10 days after it is signed.

**Clerk of Court (complete Part 5)**

**Line 13: Interest** is calculated at the rate of 1.5 percent per month starting from the first day of the month after the month of certification of this form through the last day of the month in which the sale will be held. Multiply the calculated rate by the total of **Line 7**, minus **Line 6**, plus **Lines 8** through **12**. Enter the amount on **Line 13**.

**Line 14:** Enter the total of Lines 8-13. Complete Lines 15-18, if applicable.

# APPLICATION FOR TAX DEED

Section 197.502, Florida Statutes

512  
R. 12/16

Application Number: 2400385

To: Tax Collector of ESCAMBIA COUNTY, Florida

I,  
JUAN C CAPOTE  
MIKON FINANCIAL SERVICES, INC. AND OCEAN BANK  
780 NW 42 AVE #204  
MIAMI, FL 33126,

hold the listed tax certificate and hereby surrender the same to the Tax Collector and make tax deed application thereon:

Account Number	Certificate No.	Date	Legal Description
07-1794-000	2022/3175	06-01-2022	LT 5 BLK 7 1ST ADDN TO PEN HAVEN PB 3 P 14 OR 7934 P 1144 CA 173

I agree to:

- pay any current taxes, if due and
- redeem all outstanding tax certificates plus interest not in my possession, and
- pay all delinquent and omitted taxes, plus interest covering the property.
- pay all Tax Collector's fees, property information report costs, Clerk of the Court costs, charges and fees, and Sheriff's costs, if applicable.

Attached is the tax sale certificate on which this application is based and all other certificates of the same legal description which are in my possession.

Electronic signature on file  
JUAN C CAPOTE  
MIKON FINANCIAL SERVICES, INC. AND OCEAN BANK  
780 NW 42 AVE #204  
MIAMI, FL 33126

04-17-2024  
Application Date

\_\_\_\_\_  
Applicant's signature



# Chris Jones Escambia County Property Appraiser

[Real Estate Search](#)

[Tangible Property Search](#)

[Sale List](#)

[Back](#)

← Nav. Mode  Account  Parcel ID →

[Printer Friendly Version](#)

General Information		Assessments				
<b>Parcel ID:</b>	342S301151005007	<b>Year</b>	<b>Land</b>	<b>Imprv</b>	<b>Total</b>	<b>Cap Val</b>
<b>Account:</b>	071794000	2023	\$12,500	\$104,794	\$117,294	\$104,961
<b>Owners:</b>	SCOTT DALTON ALAN BOYD SCOTT VAN ALAN	2022	\$7,000	\$94,904	\$101,904	\$101,904
<b>Mail:</b>	3 NORWOOD DR PENSACOLA, FL 32506	2021	\$7,000	\$74,722	\$81,722	\$80,755
<b>Situs:</b>	3 NORWOOD DR 32506	<b>Disclaimer</b>				
<b>Use Code:</b>	SINGLE FAMILY RESID	<b>Tax Estimator</b>				
<b>Taxing Authority:</b>	COUNTY MSTU	<b>File for Exemption(s) Online</b>				
<b>Tax Inquiry:</b>	<a href="#">Open Tax Inquiry Window</a>	<b>Report Storm Damage</b>				
Tax Inquiry link courtesy of Scott Lunsford Escambia County Tax Collector						

Sales Data						2023 Certified Roll Exemptions
Sale Date	Book	Page	Value	Type	Official Records (New Window)	HOMESTEAD EXEMPTION
07/18/2018	7934	1144	\$100	QC		
07/17/2018	7933	1781	\$100	OT		
05/21/2013	7019	335	\$100	QC		
01/10/2013	6959	1153	\$100	QC		
01/1969	429	750	\$11,500	WD		
Official Records Inquiry courtesy of Pam Childers Escambia County Clerk of the Circuit Court and Comptroller						<b>Legal Description</b> LT 5 BLK 7 1ST ADDN TO PEN HAVEN PB 3 P 14 OR 7934 P 1144 CA 173
						<b>Extra Features</b> None

**Section Map Id:**  
CA173

**Approx. Acreage:**  
0.2224

**Zoned:**

- MDR
- MDR
- MDR
- MDR
- MDR
- MDR
- MDR
- MDR
- MDR
- MDR
- MDR
- MDR
- MDR

[Launch Interactive Map](#)

[View Florida Department of Environmental Protection \(DEP\) Data](#)

MDR

**Evacuation  
& Flood  
Information**  
Open  
Report

**Buildings**

Address: 3 NORWOOD DR, Year Built: 1953, Effective Year: 1970, PA Building ID#: 83444

**Structural Elements**

DECOR/MILLWORK-AVERAGE  
DWELLING UNITS-1  
EXTERIOR WALL-CONCRETE BLOCK  
FLOOR COVER-CARPET  
FOUNDATION-SLAB ON GRADE  
HEAT/AIR-CENTRAL H/AC  
INTERIOR WALL-DRYWALL-PLASTER  
NO. PLUMBING FIXTURES-3  
NO. STORIES-1  
ROOF COVER-COMPOSITION SHG  
ROOF FRAMING-GABLE  
STORY HEIGHT-0  
STRUCTURAL FRAME-MASONRY PIL/STL

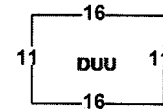

**Areas - 2097 Total SF**

BASE AREA - 1486  
CARPORT UNF - 387  
DET UTILITY UNF - 176  
OPEN PORCH FIN - 48

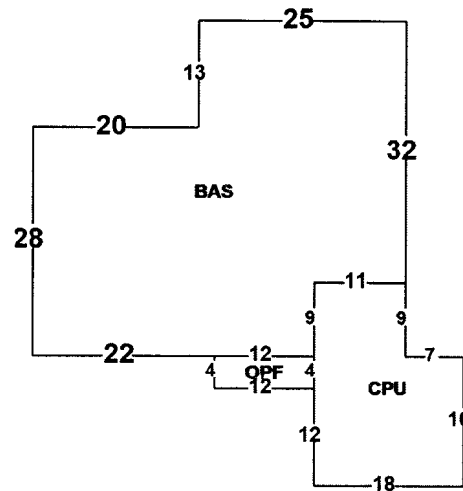

**Images**



7/18/2023 12:00:00 AM

The primary use of the assessment data is for the preparation of the current year tax roll. No responsibility or liability is assumed for inaccuracies or errors.

## NOTICE OF APPLICATION FOR TAX DEED

NOTICE IS HEREBY GIVEN, That **MIKON FINANCIAL SERVICES INC AND OCEAN BANK** holder of **Tax Certificate No. 03175**, issued the **1st** day of **June, A.D., 2022** has filed same in my office and has made application for a tax deed to be issued thereon. Said certificate embraces the following described property in the County of Escambia, State of Florida, to wit:

**LT 5 BLK 7 1ST ADDN TO PEN HAVEN PB 3 P 14 OR 7934 P 1144 CA 173**

**SECTION 34, TOWNSHIP 2 S, RANGE 30 W**

**TAX ACCOUNT NUMBER 071794000 (0125-28)**

The assessment of the said property under the said certificate issued was in the name of

**DALTON ALAN BOYD SCOTT and VAN ALAN SCOTT**

Unless said certificate shall be redeemed according to law, the property described therein will be sold to the highest bidder at public auction at 9:00 A.M. on the **second** Wednesday in the month of January, which is the **8th day of January 2025**.

Dated this 1st day of May 2024.

In accordance with the AMERICANS WITH DISABILITIES ACT, if you are a person with a disability who needs special accommodation in order to participate in this proceeding you are entitled to the provision of certain assistance. Please contact Emily Hogg not later than seven days prior to the proceeding at Escambia County Government Complex, 221 Palafox Place Ste 110, Pensacola FL 32502. Telephone: 850-595-3793.



PAM CHILDERS  
CLERK OF THE CIRCUIT COURT  
ESCAMBIA COUNTY, FLORIDA

By:  
Emily Hogg  
Deputy Clerk



**PROPERTY INFORMATION REPORT**  
3050 Concho Drive, Pensacola, Florida 32507 | Phone: 850-466-3077

THE ATTACHED REPORT IS ISSUED TO:

SCOTT LUNSFORD, ESCAMBIA COUNTY TAX COLLECTOR

TAX ACCOUNT #: 07-1794-000 CERTIFICATE #: 2022-3175

THIS REPORT IS NOT TITLE INSURANCE. THE LIABILITY FOR ERRORS OR OMISSIONS IN THIS REPORT IS LIMITED TO THE PERSON(S) EXPRESSLY IDENTIFIED BY NAME IN THE PROPERTY INFORMATION REPORT AS THE RECIPIENT(S) OF THE PROPERTY INFORMATION REPORT.

The attached Report prepared in accordance with the instructions given by the user named above includes a listing of the owner(s) of record of the land described herein together with current and delinquent ad valorem tax information and a listing and copies of all open or unsatisfied leases, mortgages, judgments and encumbrances recorded in the Official Record Books of Escambia County, Florida that appear to encumber the title to said land as listed on page 2 herein. It is the responsibility of the party named above to verify receipt of each document listed. If a copy of any document listed is not received, the office issuing this Report must be contacted immediately.

**This Report is subject to:** Current year taxes; taxes and assessments due now or in subsequent years; oil, gas, and mineral or any subsurface rights of any kind or nature; easements, restrictions and covenants of record; encroachments, overlaps, boundary line disputes, and any other matters that would be disclosed by an accurate survey and inspection of the premises.

This Report does not insure or guarantee the validity or sufficiency of any document attached, nor is it to be considered a title insurance policy, an opinion of title, a guarantee of title, or as any other form of guarantee or warranty of title.

Use of the term "Report" herein refers to the Property Information Report and the documents attached hereto.

Period Searched: September 02, 2004 to and including September 02, 2024 Abstractor: Mike Campbell

BY

Michael A. Campbell,  
As President  
Dated: September 9, 2024

**PROPERTY INFORMATION REPORT**  
**CONTINUATION PAGE**

September 9, 2024

Tax Account #: **07-1794-000**

1. The Grantee(s) of the last deed(s) of record is/are: **VAN ALAN SCOTT AND DALTON ALAN BOYD SCOTT, AS JOINT TENANTS WITH RIGHTS OF SURVIVORSHIP**

**By Virtue of Quit Claim Deed recorded 7/18/2018 in OR 7934/1144**

2. The land covered by this Report is: **See Attached Exhibit "A"**
3. The following unsatisfied mortgages, liens, and judgments affecting the land covered by this Report appear of record:
  - a. **Lien in favor of the State of FL/Escambia County recorded 4/24/2019 – OR 8083/761**
  - b. **Judgment in favor of Portfolio Recovery Associates, LLC recorded 9/1/2006 – OR 5984/455, together with Order recorded 9/6/2007 – OR 6213/1010**
  - c. **Judgment in favor of State of FL/Escambia County recorded 6/27/2024 OR 9167/441**

4. Taxes:

**Taxes for the year(s) 2021-2023 are delinquent.**

**Tax Account #: 07-1794-000**

**Assessed Value: \$104,961**

**Exemptions: HOMESTEAD**

5. We find the following HOA names in our search (if a condominium, the condo docs book and page are included for your review): **NONE**

Payment of any special liens/assessments imposed by City, County, and/or State.

Note: Escambia County and/or local municipalities may impose special liens/assessments. These liens/assessments are not discovered in a title search or shown above. These special assessments typically create a lien on real property. The entity that governs subject property must be contacted to verify payment status.





**PROPERTY INFORMATION REPORT**

**September 9, 2024**

**Tax Account #:07-1794-000**

**LEGAL DESCRIPTION  
EXHIBIT "A"**

**LT 5 BLK 7 1ST ADDN TO PEN HAVEN PB 3 P 14 OR 7934 P 1144 CA 173**

**SECTION 34, TOWNSHIP 2 S, RANGE 30 W**

**TAX ACCOUNT NUMBER 07-1794-000(0125-28)**

Recorded in Public Records 7/18/2018 8:08 AM OR Book 7934 Page 1144,  
Instrument #2018056155, Pam Childers Clerk of the Circuit Court Escambia  
County, FL Recording \$18.50 Deed Stamps \$0.70

**Prepared By**

Name: Kembrlee Scott Potter  
Address: 612 S 1<sup>st</sup> Street, Unit 34  
City: Pensacola  
State: Florida Zip Code: 32506

**After Recording Return To**

Name: Van Alan Scott  
Address: 3 Norwood Drive  
City: Pensacola  
State: Florida Zip Code: 32506

Space Above This Line for Recorder's Use

**FLORIDA QUIT CLAIM DEED**

STATE OF FLORIDA

ESCAMBIA COUNTY

KNOW ALL MEN BY THESE PRESENTS, That for and in consideration of the sum of One Hundred Dollars (\$100.00) in hand paid to Kembrlee Scott Potter, a married woman, residing at 612 S 1<sup>st</sup> Street, Unit 34, County of Escambia, City of Pensacola, State of Florida (hereinafter known as the "Grantor(s)") hereby quitclaims to Van Alan Scott, a married man, and Dalton Alan Boyd Scott, an unmarried man, (*as joint tenants with rights of survivorship*) residing at 3 Norwood Drive, County of Escambia, City of Pensacola, State of Florida (hereinafter known as the "Grantee(s)") all the rights, title, interest, and claim in or to the following described real estate, situated in Escambia County, Florida to-wit:

Property Tax Parcel/Account Number: **34-2S-30-1151-005-007**

**Lot 5, Block 7, first addition to Pen Haven, a subdivision according to plat recorded in Plat Book 3, at Page 14, of the Public Records of Escambia County, Florida.**

**To have and to hold**, the same together with all and singular the appurtenances thereunto belonging or in anywise appertaining, and all the estate, right, title, interest, lien, equity and claim whatsoever for the said first party, either in law or equity, to the only proper use, benefit and behoof of the said second party forever.

BK: 7934 PG: 1145 Last Page

Kembrlee Scott Potter  
Grantor's Signature

Kembrlee Scott Potter  
Grantor's Name

612 S. 1st Street, Unit 34  
Address

Pensacola, FL 32507  
City, State & Zip

\_\_\_\_\_  
Grantor's Signature

\_\_\_\_\_  
Grantor's Name

\_\_\_\_\_  
Address

\_\_\_\_\_  
City, State & Zip

**In Witness Whereof,**

Whitney Coppage  
Witness's Signature

Whitney Coppage  
Witness's Name

221 Palatka Place Suite 110  
Address

Pensacola, FL 32502  
City, State & Zip

Ashley Walker  
Witness's Signature

Ashley Walker  
Witness's Name

221 Palatka Place Suite 110  
Address

Pensacola FL 32502  
City, State & Zip

STATE OF FLORIDA)

COUNTY OF Escambia)

I, the undersigned, a Notary Public in and for said County, in said State, hereby certify that Kembrlee Scott Potter whose names are signed to the foregoing instrument, and who is known to me, acknowledged before me on this day that, being informed of the contents of the instrument, they, executed the same voluntarily on the day the same bears date.

Given under my hand this 18<sup>th</sup> day of July, 2018.

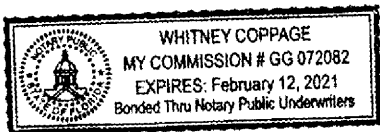

Whitney Coppage  
Notary Public

My Commission Expires: 02-12-2021

Filing # 88177418 E-Filed 04/18/2019 11:09:45 AM

IN THE CIRCUIT COURT IN AND FOR ESCAMBIA COUNTY, FLORIDA

STATE OF FLORIDA,

Plaintiff,

vs.

Dalton Allen Boyd Scott  
3 Norwood Drive  
Pensacola, FL 32506

Defendant.

CASE NO: 2018 CF 006718 A

DIVISION: A

CIVIL LIEN

**THIS CAUSE** came before the Court for assessment of Electronic Monitoring Fees. Upon the evidence presented, the Court assessed a \$785.00 Electronic Monitoring Fee. Total of **\$785.00** is due to **Department of Community Corrections**. Accordingly, pursuant to the provisions of §938.30, Florida Statutes, it is,

**ORDERED AND ADJUDGED** that the above-named Defendant shall pay arrears to the **Department of Community Corrections**, in the amount of \$785.00 which shall accrue interest at the rate of **6.33%** per annum.

**ORDERED FURTHER** that nothing in this Civil Lien will bar any subsequent civil remedy or recovery, but the amount paid under this order shall be a set-off against any subsequent independent civil recovery. Any default in payment of the amount due hereunder may be collected by any means authorized by law for the enforcement of a civil judgment, for which let execution issue.

**DONE AND ORDERED** in Chambers, at Pensacola, Escambia County, Florida.

cc: **Community Corrections Accounting Defendant**

  
eSigned by CIRCUIT COURT JUDGE STEPHEN PITRE in 2018 CF-006718 A on 04/18/2019 10:08:32 ZscPpuy

CERTIFIED TO BE A TRUE COPY OF THE ORIGINAL ON FILE IN THIS OFFICE. WITNESS MY HAND AND OFFICIAL SEAL.  
PAM CHILDERS  
CLERK OF THE CIRCUIT COURT & COMPTROLLER  
ESCAMBIA COUNTY, FLORIDA  
BY: *Kim French* D.C.  
DATE: *4-24-2019*



CERTIFIED TO BE A TRUE COPY  
OF THE ORIGINAL ON FILE IN THIS  
WITNESS MY HAND AND OFFICIAL SEAL  
ERNIE LEE MAGAHA, CLERK  
CIRCUIT COURT AND COUNTY COURT  
ESCAMBIA COUNTY FLORIDA

BY Cynthia Jean D.C.  
DATE 8-31-2006

IN THE COUNTY COURT IN AND  
FOR ESCAMBIA COUNTY, FLORIDA

CASE NO: 2006-CC-1686

PORTFOLIO RECOVERY  
ASSOCIATES, LLC

Plaintiff

vs.

VAN A SCOTT

Defendant(s)

FINAL JUDGMENT EXECUTION  
WITHHELD

Ernie Lee Magaha  
CLERK OF THE CIRCUIT COURT  
ESCAMBIA COUNTY FLORIDA  
INST# 200609118 09/12/2006 at 01:02 PM  
OFF REC BK: 5828 PG: 479 - 479 Doc Type: FJ

IT IS HEREBY Ordered and Adjudged as follows:

1. Plaintiff is entitled to a Final Judgment Execution Withheld against the Defendant(s).
2. Payment(s) of more than the amount of the installment due or down payment shall not relieve the Defendant(s) of its obligations to make the next monthly payment on the date agreed to. In the event that Defendant(s) fail to make any payment when due the Plaintiff shall be entitled to an execution order for the full amount then owing plus costs, interest and reasonable attorneys' fees to be determined by the Court.
3. It is agreed that Plaintiff, whose address is 140 Corporate Blvd, Suite #100, Norfolk, VA 23502, shall recover from the Defendant(s) the principal sum of \$9,135.30, court costs in the amount of \$275.00, pre-judgment interest in the amount of \$6,914.76, attorney's fees in the amount of \$400.00, and post judgment interest at the rate of 24.980% per annum, to be paid as follows: the sum of \$150.00, due on or before 05/02/06, and the sum of \$150.00, which shall be due on or before the 2nd day of each month thereafter until paid in full.
4. That in the event of default, Plaintiff shall be entitled to an execution order upon the filing of a verified notice of default by counsel for Plaintiff without notice or hearing.

DONE AND ORDERED at Pensacola, Escambia County, Florida on this the 7<sup>th</sup> day of

August, 2006.

[Signature]  
COUNTY COURT JUDGE

Copies furnished to:  
HAYT, HAYT & LANDAU  
7765 SW 87 Ave, Suite 101  
Miami, Fl 33173

VAN A SCOTT  
3117 Fayal Dr  
Pensacola Florida 32526  
05-04465-0 4264291999311507

Case: 2006 CC 001686  
00062885271  
Dkt: CC1033 Pg#: 1

IN THE COUNTY COURT IN AND  
FOR ESCAMBIA COUNTY, FLORIDA  
CASE NO: 2006-CC-1686

PORTFOLIO RECOVERY  
ASSOCIATES, LLC

Plaintiff,

ORDER FOR EXECUTION

vs.

VAN A SCOTT

Defendant(s).

THIS CAUSE having come on to be heard before me upon the Plaintiff's Verified Notice of Default and Demand for Execution Order, and it appearing that the Defendant(s) has/have failed to abide by the Final Judgment Execution Withheld heretofore entered by this Court on June 7, 2006 and the Court, being otherwise fully advised in the premises, it is, upon consideration,

ORDERED AND ADJUDGED that:

Execution is hereby issued for the Judgment entered on June 7, 2006. There remains due and owing a principal balance on said stipulation of \$9,135.30, attorney's fees in the amount of \$400.00, and interest in the amount of \$10,502.63. In addition, to the Judgment amount, Plaintiff is entitled to attorneys fees in the sum of \$ 750, that shall accrue interest at the rate of 24.980%, for all of the above let execution issue.

IT IS FURTHER ORDERED AND ADJUDGED THAT:

The Defendant(s) shall complete under oath the attached Fact Information Sheet (Florida Rules of Civil Procedure Form 1.977) including all required attachments, and return it to the Plaintiff's attorney, within 45 days from the date of this Order, unless the Order is satisfied or a post judgment discovery is stayed.

Jurisdiction of this case is retained to enter further orders that are proper to compel the Defendant(s) to complete the Fact Information Sheet and return it to the Plaintiff's attorney.

DONE AND ORDERED at Pensacola, Escambia County, Florida on this the

27 day of August, 2007

  
\_\_\_\_\_  
COUNTY COURT JUDGE

Copies furnished to:  
HAYT, HAYT & LANDAU  
Attorneys for Plaintiff  
7765 SW 87 Ave, Suite 101  
Miami, Florida 33173

VAN A SCOTT  
3117 Fayal Dr  
Pensacola Florida 32526  
05-04465-0

CLERK OF CIRCUIT COURT  
ESCAMBIA COUNTY, FL  
2007 AUG 27 A 9 18  
COUNTY CIVIL DIVISION  
FILED & RECORDED

Case: 2006 CC 001686  
  
00085673544  
Dkt: cc1071 Pg#: 3

**FORM 1.977  
FACT INFORMATION SHEET**

Full Legal Name: \_\_\_\_\_

Nicknames or Aliases: \_\_\_\_\_

Residence Address: \_\_\_\_\_

Mailing Address (if different): \_\_\_\_\_

Telephone Numbers (Home) \_\_\_\_\_ (Business) \_\_\_\_\_

Name of Employer: \_\_\_\_\_

Address of Employer: \_\_\_\_\_

Position or Job Description: \_\_\_\_\_

Rate of Pay: \$ \_\_\_\_\_ per \_\_\_\_\_ . Average Paycheck: \$ \_\_\_\_\_ per \_\_\_\_\_

Average Commissions or Bonuses \$ \_\_\_\_\_ per \_\_\_\_\_ . Commissions or Bonuses are based on \_\_\_\_\_

Other Personal Income: \$ \_\_\_\_\_ from \_\_\_\_\_

(Explain details on the back of this sheet or an additional sheet if necessary.)

Social Security Number: \_\_\_\_\_ Birth date: \_\_\_\_\_

Driver's License Number: \_\_\_\_\_

Marital Status: \_\_\_\_\_ Spouse's Name: \_\_\_\_\_

Spouse's Address (if different): \_\_\_\_\_

Spouse's Social Security Number: \_\_\_\_\_ Birth date: \_\_\_\_\_

Spouse's Employer: \_\_\_\_\_

Spouses's Average Paycheck or Income: \$ \_\_\_\_\_ per \_\_\_\_\_

Other Family Income: \$ \_\_\_\_\_ from \_\_\_\_\_

(Explain details on the back of this sheet or an additional sheet if necessary.)

Names and Ages of All of Children (and addresses if not living with you): \_\_\_\_\_

Child Support or Alimony Paid \$ \_\_\_\_\_ per \_\_\_\_\_

Names of Others You Live With: \_\_\_\_\_

Who is Head of Your Household? \_\_\_\_\_ You \_\_\_\_\_ Spouse \_\_\_\_\_ Other Person

Checking Account at: \_\_\_\_\_ Account # \_\_\_\_\_

Savings Account at: \_\_\_\_\_ Account # \_\_\_\_\_

(Describe all other accounts or investments you may have, including stocks, mutual funds savings bonds, or annuities, on the back of this sheet or an additional sheet if necessary.)

**For Real Estate (land) You Own or Are Buying:**

Address: \_\_\_\_\_

All Names on Title: \_\_\_\_\_

Mortgage Owed to: \_\_\_\_\_

Balance Owed: \_\_\_\_\_

Monthly Payment: \_\_\_\_\_

(Attach a copy of the deed or mortgage, or list the legal description of the property on the back of this sheet or an additional sheet if necessary. Also provide the same information on any other property you own or are buying.)

**For All Motor Vehicles You Own or Are Buying:**

Year/Make/Model: \_\_\_\_\_ Color: \_\_\_\_\_

Vehicle ID#: \_\_\_\_\_ Tag No: \_\_\_\_\_ Mileage: \_\_\_\_\_

Names on title: \_\_\_\_\_ Present Value: \$ \_\_\_\_\_

Loan Owed to: \_\_\_\_\_



Balance on Loan: \_\_\_\_\_  
Monthly Payment: \$ \_\_\_\_\_ (List all other automobiles, as well as other vehicles, such as boats, motorcycles, bicycles, or aircraft, on the back of this sheet or an additional sheet if necessary.)  
\_\_\_\_\_  
\_\_\_\_\_

Have you given, sold, loaned, or transferred any real or personal property worth more than \$100 to any persons in the last year? If your answer is "Yes" describe the property and sale price, and give the names and address of the persons who received the property.

Does anyone owe you money? Amount owed: \$ \_\_\_\_\_  
Names and Address of Person Owing Money: \_\_\_\_\_  
Reason money is owed: \_\_\_\_\_

Please attach copies of the following:

- a. Your last pay stub.
- b. Your last 3 statements for each bank, savings, credit union, or other financial account.
- c. Your motor vehicle registrations and titles.
- d. Any deeds or titles to any real or personal property you own or are buying, or leases to property you are renting.

UNDER PENALTY OF PERJURY, I SWEAR OR AFFIRM THAT THE FOREGOING ANSWERS ARE TRUE AND COMPLETE.

\_\_\_\_\_  
JUDGMENT DEBTOR

STATE OF FLORIDA  
COUNTY OF \_\_\_\_\_

The foregoing instrument was acknowledged before me this \_\_\_\_\_ day of \_\_\_\_\_, 20\_\_\_\_, by \_\_\_\_\_, who is personally known to me or has produced \_\_\_\_\_ as identification and who \_\_ did/did\_\_ not take an oath.

WITNESS my hand and official seal, this \_\_\_\_\_ day of \_\_\_\_\_, 20\_\_\_\_

\_\_\_\_\_  
Notary Public  
State of Florida

My Commission expires:

**MAIL OR DELIVER THIS FORM TO THE CLERK OF THE COURT, AND MAIL OR DELIVER A COPY OF THE COMPLETED FORM TO THE JUDGMENT CREDITOR'S ATTORNEY.**

Recorded in Public Records 6/27/2024 3:02 PM OR Book 9167 Page 441,  
Instrument #2024049416, Pam Childers Clerk of the Circuit Court Escambia  
County, FL



## Electronically Certified Court Record

This is to certify that this is a true and correct copy of the original document, which may have redactions as required by law.

---

### DOCUMENT INFORMATION

<b>Agency Name:</b>	Escambia County Clerk of the Court and Comptroller
<b>Clerk of the Circuit Court:</b>	The Honorable Pam Childers
<b>Date Issued:</b>	6/27/2024 7:15:19 AM
<b>Unique Reference Number:</b>	CAA-CACABFBCCDAHCG-BCADD-BDIBDIAAG-JDGADA-J
<b>Case Number:</b>	172018CF006718XXXAXX
<b>Case Docket:</b>	CIVIL LIEN FOR UNPAID FINES & COSTS
<b>Requesting Party Code:</b>	20201512230726
<b>Requesting Party Reference:</b>	cassie.gilmore@escambiaclerk.com

---

### CERTIFICATION

Pursuant to Sections 90.955(1) and 90.902(1), Florida Statutes, and Federal Rules of Evidence 901(a), 901(b)(7), and 902(1), the attached document is electronically certified by The Honorable Pam Childers, Escambia County Clerk of the Court and Comptroller, to be a true and correct copy of an official record or document authorized by law to be recorded or filed and actually recorded or filed in the office of the Escambia Clerk of the Court. The document may have redactions as required by law.

### HOW TO VERIFY THIS DOCUMENT

This document contains a Unique Reference Number for identification purposes and a tamper-evident seal to indicate if the document has been tampered with. To view the tamper-evident seal and verify the certifier's digital signature, open this document with Adobe Reader software. You can also verify this document by scanning the QR code or visiting <https://Verify.Clerkecertify.com/VerifyImage>.

\*\*The web address shown above contains an embedded link to the verification page for this particular document.



BK: 9167 PG: 442 Last Page

Filing # 201407918 E-Filed 06/26/2024 03:18:09 PM

IN THE CIRCUIT COURT IN AND FOR ESCAMBIA COUNTY, FLORIDA

STATE OF FLORIDA

VS

CASE NO: 2018 CF 006718 A

DALTON ALLEN BOYD SCOTT  
3 NORWOOD DRIVE  
PENSACOLA, FL 32506

DIVISION: A  
DATE OF BIRTH: 09/23/1999

FINAL JUDGMENT FOR FINES, COSTS, AND ADDITIONAL CHARGES

On JUNE 19, 2024, an order assessing fines, costs, and additional charges was entered against the Defendant, DALTON ALLEN BOYD SCOTT. Defendant has failed to make payment in full in accordance with this order. Therefore,

IT IS ADJUDGED that the Escambia County Clerk of the Circuit Court, 190 W GOVERNMENT ST, PENSACOLA, FLORIDA 32502 recover from Defendant those remaining unpaid fines, costs and additional charges in the amount of \$200.00, which shall bear interest at the rate prescribed by law, 9.34%, until satisfied.

It is FURTHER ORDERED AND ADJUDGED that a lien is hereby created against all currently owned and after acquired property, both real and personal, of the defendant.

FOR WHICH LET EXECUTION ISSUE.

DONE AND ORDERED in open court/chambers in Pensacola, Escambia County, Florida.

06/26/2024 13:18:04  
2018 CF 006718 A

signed by CIRCUIT COURT JUDGE COLEMAN L. ROBINSON 06/26/2024 01:18:04 QHlpEPw8

CIRCUIT JUDGE

(CFCTMMFNLCHRGS2 #24984)

Unique Code : CAA-CACABFBCCDAHCG-BCADD-BDIBDIAAG-JDGADA-J Page 1 of 1

I HEREBY CERTIFY THAT THIS DOCUMENT IS A TRUE AND CORRECT COPY OF AN OFFICIAL RECORD OR DOCUMENT AUTHORIZED BY LAW TO BE RECORDED OR FILED AND ACTUALLY RECORDED OR FILED IN THE OFFICE OF THE ESCAMBIA COUNTY CLERK OF THE CIRCUIT COURT. THIS DOCUMENT MAY HAVE REDACTIONS AS REQUIRED BY LAW. VISIT <https://www.escambiacountyclerk.com/verify> TO VALIDATE THIS DOCUMENT



Digitally signed by Pamela L Childers  
Date: 2024.06.27 07:15:21 -05:00  
Escambia County Clerk of the Court and Comptroller  
Location: 190 W Government St., Pensacola, FL 32502