



# CERTIFICATION OF TAX DEED APPLICATION

Sections 197.502 and 197.542, Florida Statutes

DR-513  
Rule 12D-16.002 F.A.C  
Effective 07/19  
Page 1 of 2

1024-19

Part 1: Tax Deed Application Information			
Applicant Name Applicant Address	ASSEMBLY TAX 36, LLC ASSEMBLY TAX 36 LLC FBO SEC PTY PO BOX 12225 NEWARK, NJ 07101-3411	Application date	Apr 11, 2024
Property description	WARREN DENNIS 3499 N ALCANIZ ST PENSACOLA, FL 32503 1815 N 58TH AVE 05-4401-000 BEG AT SE COR OF LT 6 N ALG E LI 1020 FT W 266 FT FOR POB CONTINUE W 394 FT N 150 FT E 394 FT S 150 (Full legal attached.)	Certificate #	2022 / 2343
		Date certificate issued	06/01/2022

Part 2: Certificates Owned by Applicant and Filed with Tax Deed Application				
Column 1 Certificate Number	Column 2 Date of Certificate Sale	Column 3 Face Amount of Certificate	Column 4 Interest	Column 5: Total (Column 3 + Column 4)
# 2022/2343	06/01/2022	1,992.91	99.65	2,092.56
<b>→Part 2: Total*</b>				<b>2,092.56</b>

Part 3: Other Certificates Redeemed by Applicant (Other than County)					
Column 1 Certificate Number	Column 2 Date of Other Certificate Sale	Column 3 Face Amount of Other Certificate	Column 4 Tax Collector's Fee	Column 5 Interest	Total (Column 3 + Column 4 + Column 5)
# 2023/2308	06/01/2023	2,177.40	6.25	134.73	2,318.38
<b>Part 3: Total*</b>					<b>2,318.38</b>

Part 4: Tax Collector Certified Amounts (Lines 1-7)	
1. Cost of all certificates in applicant's possession and other certificates redeemed by applicant (*Total of Parts 2 + 3 above)	4,410.94
2. Delinquent taxes paid by the applicant	0.00
3. Current taxes paid by the applicant	2,168.04
4. Property information report fee	200.00
5. Tax deed application fee	175.00
6. Interest accrued by tax collector under s.197.542, F.S. (see Tax Collector Instructions, page 2)	0.00
7. <b>Total Paid (Lines 1-6)</b>	<b>6,953.98</b>

I certify the above information is true and the tax certificates, interest, property information report fee, and tax collector's fees have been paid, and that the property information statement is attached.

Sign here: Candice Lewis Signature, Tax Collector or Designee

Escambia, Florida  
Date April 22nd, 2024

Send this certification to the Clerk of Court by 10 days after the date signed. See Instructions on Page 2

<b>Part 5: Clerk of Court Certified Amounts (Lines 8-14)</b>	
8. Processing tax deed fee	
9. Certified or registered mail charge	
10. Clerk of Court advertising, notice for newspaper, and electronic auction fees	
11. Recording fee for certificate of notice	
12. Sheriff's fees	
13. Interest (see Clerk of Court Instructions, page 2)	
14. <b>Total Paid (Lines 8-13)</b>	
15. Plus one-half of the assessed value of homestead property, if applicable under s. 197.502(6)(c), F.S.	
16. Statutory opening bid (total of Lines 7, 14, 15, and 16 if applicable)	
Sign here: _____ Date of sale <u>10/02/2024</u>	
Signature, Clerk of Court or Designee	

INSTRUCTIONS + 6.25

**Tax Collector (complete Parts 1-4)**

**Part 2: Certificates Owned by Applicant and Filed with Tax Deed Application**

Enter the Face Amount of Certificate in Column 3 and the Interest in Column 4 for each certificate number. Add Columns 3 and 4 and enter the amount in Column 5.

**Part 3: Other Certificates Redeemed by Applicant (Other than County)**

Total. Add the amounts in Columns 3, 4 and 5

**Part 4: Tax Collector Certified Amounts (Lines 1-7)**

Line 1, enter the total of Part 2 plus the total of Part 3 above.

Total Paid, Line 7: Add the amounts of Lines 1-6

**Line 6, Interest accrued by tax collector.** Calculate the 1.5 percent interest accrued from the month after the date of application through the month this form is certified to the clerk. Enter the amount to be certified to the clerk on Line 6. The interest calculated by the tax collector stops before the interest calculated by the clerk begins. See Section 197.542, F.S., and Rule 12D-13.060(3), Florida Administrative Code.

The tax collector's interest for redemption at the time of the tax deed application is a cost of redemption, which encompasses various percentages of interest on certificates and omitted or delinquent taxes under Section 197.502, F.S. This interest is calculated before the tax collector calculates the interest in Section 197.542, F.S.

Attach certified statement of names and addresses of persons who must be notified before the sale of the property. Send this form and any required attachments to the Clerk of Court within 10 days after it is signed.

**Clerk of Court (complete Part 5)**

**Line 13: Interest** is calculated at the rate of 1.5 percent per month starting from the first day of the month after the month of certification of this form through the last day of the month in which the sale will be held. Multiply the calculated rate by the total of Line 7, minus Line 6, plus Lines 8 through 12. Enter the amount on Line 13.

**Line 14:** Enter the total of Lines 8-13. Complete Lines 15-18, if applicable.

BEG AT SE COR OF LT 6 N ALG E LI 1020 FT W 266 FT FOR POB CONTINUE W 394 FT N 150 FT E 394 FT S 150 FT TO POB OR 813 P 689 OR 913 P 196 LTS 55 56 OF AN UNRECORDED PLAT

# APPLICATION FOR TAX DEED

Section 197.502, Florida Statutes

512  
R. 12/16

Application Number: 2400135

To: Tax Collector of ESCAMBIA COUNTY, Florida

I,  
ASSEMBLY TAX 36, LLC  
ASSEMBLY TAX 36 LLC FBO SEC PTY  
PO BOX 12225  
NEWARK, NJ 07101-3411,

hold the listed tax certificate and hereby surrender the same to the Tax Collector and make tax deed application thereon:

Account Number	Certificate No.	Date	Legal Description
05-4401-000	2022/2343	06-01-2022	BEG AT SE COR OF LT 6 N ALG E LI 1020 FT W 266 FT FOR POB CONTINUE W 394 FT N 150 FT E 394 FT S 150 FT TO POB OR 813 P 689 OR 913 P 196 LTS 55 56 OF AN UNRECORDED PLAT

I agree to:

- pay any current taxes, if due and
- redeem all outstanding tax certificates plus interest not in my possession, and
- pay all delinquent and omitted taxes, plus interest covering the property.
- pay all Tax Collector's fees, property information report costs, Clerk of the Court costs, charges and fees, and Sheriff's costs, if applicable.

Attached is the tax sale certificate on which this application is based and all other certificates of the same legal description which are in my possession.

Electronic signature on file  
ASSEMBLY TAX 36, LLC  
ASSEMBLY TAX 36 LLC FBO SEC PTY  
PO BOX 12225  
NEWARK, NJ 07101-3411

04-11-2024  
Application Date

\_\_\_\_\_  
Applicant's signature



# Chris Jones Escambia County Property Appraiser

[Real Estate Search](#)

[Tangible Property Search](#)

[Sale List](#)

[Back](#)

← Nav. Mode  Account  Parcel ID →

[Printer Friendly Version](#)

General Information		Assessments				
<b>Parcel ID:</b>	142S306101000055	<b>Year</b>	<b>Land</b>	<b>Imprv</b>	<b>Total</b>	<b>Cap Val</b>
<b>Account:</b>	054401000	2023	\$40,980	\$110,877	\$151,857	\$141,359
<b>Owners:</b>	WARREN DENNIS	2022	\$34,901	\$104,054	\$138,955	\$128,509
<b>Mail:</b>	3499 N ALCANIZ ST PENSACOLA, FL 32503	2021	\$34,901	\$81,926	\$116,827	\$116,827
<b>Situs:</b>	1815 N 58TH AVE 32506	<b>Disclaimer</b>				
<b>Use Code:</b>	SINGLE FAMILY RESID 🔑	<b>Tax Estimator</b>				
<b>Taxing Authority:</b>	COUNTY MSTU	<b>File for Exemption(s) Online</b>				
<b>Tax Inquiry:</b>	<a href="#">Open Tax Inquiry Window</a>	<b>Report Storm Damage</b>				
Tax Inquiry link courtesy of Scott Lunsford Escambia County Tax Collector						

Sales Data						2023 Certified Roll Exemptions
<b>Sale Date</b>	<b>Book</b>	<b>Page</b>	<b>Value</b>	<b>Type</b>	<b>Official Records (New Window)</b>	None
01/1975	913	196	\$100	QC		<b>Legal Description</b> BEG AT SE COR OF LT 6 N ALG E LI 1020 FT W 266 FT FOR POB CONTINUE W 394 FT N 150 FT E 394 FT S 150 FT TO POB OR 813... 🔑
01/1974	813	689	\$28,500	WD		
Official Records Inquiry courtesy of Pam Childers Escambia County Clerk of the Circuit Court and Comptroller						<b>Extra Features</b> None

**Section**  
Map Id:  
14-2S-30-2

**Approx. Acreage:**  
1.3660

**Zoned:** 🔑  
MDR  
MDR  
MDR  
MDR  
MDR  
MDR  
MDR

**Evacuation & Flood Information** 🔑  
[View Florida Department of Environmental Protection \(DEP\) Data](#)

[Open Report](#)

Launch Interactive Map

Buildings
Address: 1815 N 58TH AVE, Year Built: 1950, Effective Year: 1956, PA Building ID#: 76500

Structural Elements

DECOR/MILLWORK-AVERAGE  
DWELLING UNITS-1  
EXTERIOR WALL-SIDING-LAP.AAVG  
EXTERIOR WALL-CONCRETE BLOCK  
FLOOR COVER-CARPET  
FOUNDATION-SLAB ON GRADE  
HEAT/AIR-CENTRAL H/AC  
INTERIOR WALL-DRYWALL-PLASTER  
NO. PLUMBING FIXTURES-6  
NO. STORIES-2  
ROOF COVER-COMPOSITION SHG  
ROOF FRAMING-HIP  
STORY HEIGHT-0  
STRUCTURAL FRAME-MASONRY PIL/STL

Areas - 2445 Total SF

BASE AREA - 1086  
GARAGE UNFIN - 713  
OPEN PORCH FIN - 190  
OPEN PORCH UNF - 96  
UPPER STORY FIN - 360

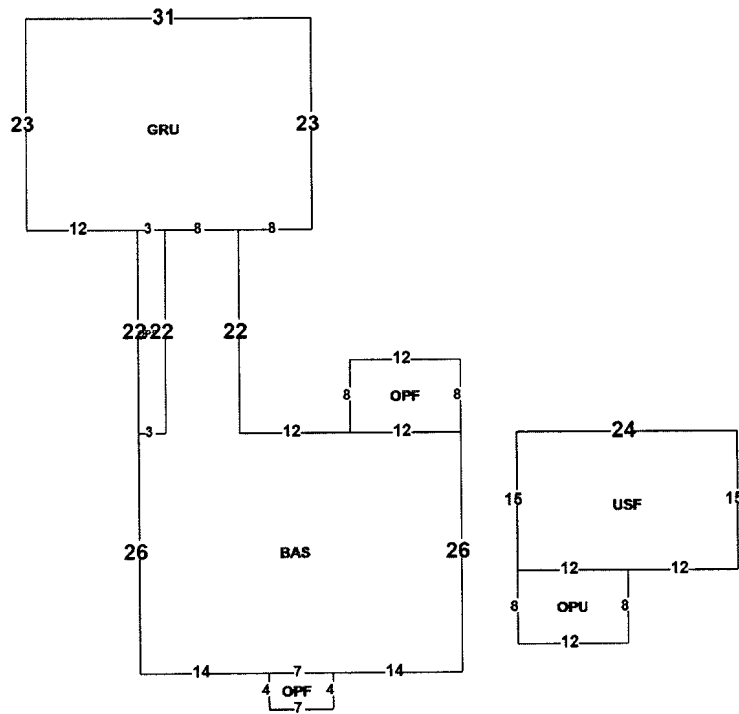

Images



10/21/2019 12:00:00 AM

The primary use of the assessment data is for the preparation of the current year tax roll. No responsibility or liability is assumed for inaccuracies or errors.

## NOTICE OF APPLICATION FOR TAX DEED

NOTICE IS HEREBY GIVEN, That **ASSEMBLY TAX 36 LLC** holder of **Tax Certificate No. 02343**, issued the **1st** day of **June, A.D., 2022** has filed same in my office and has made application for a tax deed to be issued thereon. Said certificate embraces the following described property in the County of Escambia, State of Florida, to wit:

**BEG AT SE COR OF LT 6 N ALG E LI 1020 FT W 266 FT FOR POB CONTINUE W 394 FT N 150 FT  
E 394 FT S 150 FT TO POB OR 813 P 689 OR 913 P 196 LTS 55 56 OF AN UNRECORDED PLAT**

**SECTION 14, TOWNSHIP 2 S, RANGE 30 W**

**TAX ACCOUNT NUMBER 054401000 (1024-19)**

The assessment of the said property under the said certificate issued was in the name of

**DENNIS WARREN**

Unless said certificate shall be redeemed according to law, the property described therein will be sold to the highest bidder at public auction at 9:00 A.M. on the **first** Wednesday in the month of October, which is the **2nd** day of **October 2024**.

Dated this 26th day of April 2024.

In accordance with the AMERICANS WITH DISABILITIES ACT, if you are a person with a disability who needs special accommodation in order to participate in this proceeding you are entitled to the provision of certain assistance. Please contact Emily Hogg not later than seven days prior to the proceeding at Escambia County Government Complex, 221 Palafox Place Ste 110, Pensacola FL 32502. Telephone: 850-595-3793.

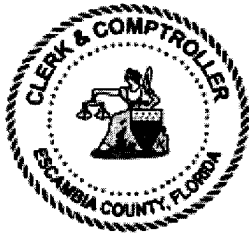

PAM CHILDERS  
CLERK OF THE CIRCUIT COURT  
ESCAMBIA COUNTY, FLORIDA

By:  
Emily Hogg  
Deputy Clerk



**PROPERTY INFORMATION REPORT**  
3050 Concho Drive, Pensacola, Florida 32507 | Phone: 850-466-3077

THE ATTACHED REPORT IS ISSUED TO:

SCOTT LUNSFORD, ESCAMBIA COUNTY TAX COLLECTOR

TAX ACCOUNT #: 05-4401-000 CERTIFICATE #: 2022-2343

THIS REPORT IS NOT TITLE INSURANCE. THE LIABILITY FOR ERRORS OR OMISSIONS IN THIS REPORT IS LIMITED TO THE PERSON(S) EXPRESSLY IDENTIFIED BY NAME IN THE PROPERTY INFORMATION REPORT AS THE RECIPIENT(S) OF THE PROPERTY INFORMATION REPORT.

The attached Report prepared in accordance with the instructions given by the user named above includes a listing of the owner(s) of record of the land described herein together with current and delinquent ad valorem tax information and a listing and copies of all open or unsatisfied leases, mortgages, judgments and encumbrances recorded in the Official Record Books of Escambia County, Florida that appear to encumber the title to said land as listed on page 2 herein. It is the responsibility of the party named above to verify receipt of each document listed. If a copy of any document listed is not received, the office issuing this Report must be contacted immediately.

**This Report is subject to:** Current year taxes; taxes and assessments due now or in subsequent years; oil, gas, and mineral or any subsurface rights of any kind or nature; easements, restrictions and covenants of record; encroachments, overlaps, boundary line disputes, and any other matters that would be disclosed by an accurate survey and inspection of the premises.

This Report does not insure or guarantee the validity or sufficiency of any document attached, nor is it to be considered a title insurance policy, an opinion of title, a guarantee of title, or as any other form of guarantee or warranty of title.

Use of the term "Report" herein refers to the Property Information Report and the documents attached hereto.

Period Searched: June 4, 2004 to and including June 4, 2024 Abstractor: Vicki Campbell

BY

Michael A. Campbell,  
As President  
Dated: June 5, 2024

**PROPERTY INFORMATION REPORT**  
**CONTINUATION PAGE**

June 5, 2024

Tax Account #: **05-4401-000**

1. The Grantee(s) of the last deed(s) of record is/are: **DENNIS O. WARREN**

**By Virtue of Quit Claim Deed recorded 7/1/1975 in OR 913/196 and Warranty Deed recorded 06/27/1974 - OR 813/689**

2. The land covered by this Report is: **See Attached Exhibit "A"**

3. The following unsatisfied mortgages, liens, and judgments affecting the land covered by this Report appear of record:

- a. **Fire Protection MSBU Lien in favor of Escambia County, Florida recorded 10/05/1998 in OR 4315/1526**
- b. **Fire Protection MSBU Lien in favor of Escambia County, Florida recorded 08/03/1999 in OR 4447/145**
- c. **Code Enforcement Lien in favor of Escambia County, Florida recorded 05/12/2008 in OR 6326/760**
- d. **Code Enforcement Lien in favor of Escambia County, Florida recorded 07/24/2017 in OR 7748/811**

4. Taxes:

**Taxes for the year(s) 2021-2023 are delinquent.**

**Tax Account #: 05-4401-000**

**Assessed Value: \$141,359.00**

**Exemptions: NONE**

5. We find the following HOA names in our search (if a condominium, the condo docs book and page are included for your review): **NONE**

Payment of any special liens/assessments imposed by City, County, and/or State.

Note: Escambia County and/or local municipalities may impose special liens/assessments. These liens/assessments are not discovered in a title search or shown above. These special assessments typically create a lien on real property. The entity that governs subject property must be contacted to verify payment status.



**PERDIDO TITLE & ABSTRACT, INC.**  
**PROPERTY INFORMATION REPORT**  
3050 Concho Drive, Pensacola, Florida 32507 | Phone 850-466-3077

**Scott Lunsford**  
**Escambia County Tax Collector**  
P.O. Box 1312  
Pensacola, FL 32591

**CERTIFICATION: TITLE SEARCH FOR TDA**

**TAX DEED SALE DATE:** \_\_\_\_\_ **OCT 2, 2024**  
**TAX ACCOUNT #:** \_\_\_\_\_ **05-4401-000**  
**CERTIFICATE #:** \_\_\_\_\_ **2022-2343**

In compliance with Section 197.522, Florida Statutes, the following is a list of names and addresses of those persons, firms, and/or agencies having legal interest in or claim against the above-described property. The above-referenced tax sale certificate is being submitted as proper notification of tax deed sale.

YES	NO	
<input type="checkbox"/>	<input checked="" type="checkbox"/>	Notify City of Pensacola, P.O. Box 12910, 32521
<input checked="" type="checkbox"/>	<input type="checkbox"/>	Notify Escambia County, 190 Governmental Center, 32502
<input type="checkbox"/>	<input checked="" type="checkbox"/>	Homestead for <u>2023</u> tax year.

**DENNIS O. WARREN**  
**1815 N. 58TH AVE**  
**PENSACOLA, FL 32503**

**DENNIS O. WARREN**  
**3499 N. ALCANIZ ST**  
**PENSACOLA, FL 32503**

**ESCAMBIA COUNTY CODE ENFORCEMENT**  
**3363 W. PARK PL**  
**PENSACOLA, FL 32505**

**Certified and delivered to Escambia County Tax Collector, this 5<sup>th</sup> day of June, 2024.**

**PERDIDO TITLE & ABSTRACT, INC.**



BY: Michael A. Campbell, As It's President

NOTE: The above listed addresses are based upon current information available, but addresses are not guaranteed to be true or correct.

**PROPERTY INFORMATION REPORT**

**June 5, 2024**

**Tax Account #:05-4401-000**

**LEGAL DESCRIPTION  
EXHIBIT "A"**

**BEG AT SE COR OF LT 6 N ALG E LI 1020 FT W 266 FT FOR POB CONTINUE W 394 FT N 150 FT  
E 394 FT S 150 FT TO POB OR 813 P 689 OR 913 P 196 LTS 55 56 OF AN UNRECORDED PLAT**

**SECTION 14, TOWNSHIP 2 S, RANGE 30 W**

**TAX ACCOUNT NUMBER 05-4401-000(1024-19)**

**ABTRACTOR'S NOTE: WE CAN NOT CERTIFY LEGAL AS WRITTEN ON TAX ROLL  
WITHOUT A CURRENT SURVEY.**

140.0 Rec  
85.50  
31.35  
120.85

WARRANTY DEED  
INDIVID. TO INDIVID

OFF REC BOOK 813 PAGE 689

RAMCO FORM 01

This Warranty Deed Made the \_\_\_\_\_ day of \_\_\_\_\_ A. D. 1974 by  
Will T. Cooper Jr. and Burnis Irene Cooper, husband and wife,  
A/KN Burnis D. Cooper  
hereinafter called the grantor, to  
Dennis O. Warren and Marcia Warren, husband and wife,

whose postoffice address is Route # 1  
hereinafter called the grantees: Pensacola, Florida

(Wherever used herein the terms "grantor" and "grantee" include all the parties to this instrument and the heirs, legal representatives and assigns of individuals, and the successors and assigns of corporations)

Witnesseth: That the grantor, for and in consideration of the sum of \$ 10.00 and other valuable considerations, receipt whereof is heruby acknowledged, hereby grants, bargains, sells, aliens, releases, conveys and confirms unto the grantees, all that certain land situate in \_\_\_\_\_ County, Florida, viz:

That certain parcel of land situate, lying and being in Section 14, Township 2 South, Range 30 West, more particularly described as follows, to-wit: Commencing at the Southeast corner of Lot 6, in said Section, Township and Range; thence run North with the East line of said Lot 6 a distance of one thousand and twenty (1020) feet; thence run Westerly two hundred sixty-six (266) feet to the point of beginning; thence continue Westerly three hundred ninety-four (394) feet; thence run North one hundred fifty (150) feet; thence run Easterly three hundred ninety-four (394) feet; thence run Southerly one hundred fifty (150) feet to the point of beginning, all lying and being in the above County.

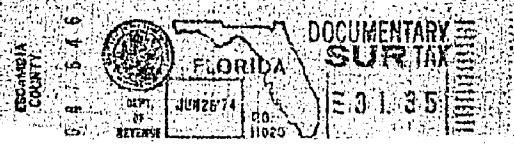

Together with all the tenements, hereditaments and appurtenances thereto belonging or in anywise appertaining.

To Have and to Hold, the same in fee simple forever.

And the grantor hereby covenants with said grantees that the grantor is lawfully seized of said land in fee simple; that the grantor has good right and lawful authority to sell and convey said land; that the grantor hereby fully warrants the title to said land and will defend the same against the lawful claims of all persons whomsoever; and that said land is free of all encumbrances, except taxes accruing subsequent to December 31, 1974.

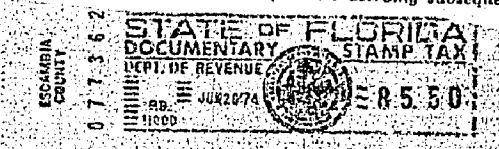

In Witness Whereof, the said grantor has signed and sealed these presents the day and year first above written.

Signed, sealed and delivered in our presence:

Betty J. Clark  
Betty Brundage

Will T. Cooper Jr.  
Burnis Irene Cooper

STATE OF FLORIDA  
COUNTY OF ESCAMBIA

I HEREBY CERTIFY that on this day, before me, an officer duly authorized in the State aforesaid and in the County aforesaid to take acknowledgments, personally appeared Will T. Cooper, Jr and Burnis Irene Cooper

to me known to be the persons described in and who executed the foregoing instrument and they acknowledged before me that they executed the same.

WITNESS my hand and official seal in the County and State last aforesaid this 27th day of June, A. D. 1974

Betty J. Clark  
My Commission Expires July 27, 1974

This instrument prepared by: THIS INSTRUMENT PREPARED BY: MARY E. BOYCETTE  
Address

SPACE BELOW FOR RECORDER'S USE  
FILED & RECORDED IN THE PUBLIC RECORDS OF ESCAMBIA CO. FLA. ON JUN 27 1 51 PM '74 IN BOOK & PAGE NOTED ABOVE JOE A. FLOWERS, CLERK ESCAMBIA COUNTY

619485

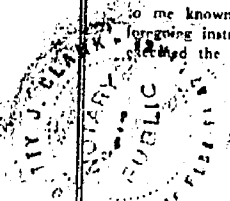

**This Quit-Claim Deed**, Executed this 14th day of June, A. D. 19 75, by  
 Marcia P. Warren, a divorced and unremarried woman  
 first party, to Dennis O. Warren, a divorced and unremarried man

whose postoffice address is 1815 N. 58th Avenue, Pensacola, Florida 32506

second party:

(Wherever used herein the terms "first party" and "second party" shall include singular and plural, heirs, legal representatives, and assigns of individuals, and the successors and assigns of corporations, wherever the context so admits or requires.)

**Witnesseth**, That the said first party, for and in consideration of the sum of \$  
 in hand paid by the said second party, the receipt whereof is hereby acknowledged, does hereby remise, re-  
 lease and quit-claim unto the said second party forever, all the right, title, interest, claim and demand which  
 the said first party has in and to the following described lot, piece or parcel of land, situate, lying and being  
 in the County of Escambia State of Florida, to-wit:

That certain parcel of land situate, lying and being in  
 Section 14, Township 2 South, Range 30 West, more particularly  
 described as follows, to-wit: Commencing at the Southeast  
 corner of Lot 6, in said Section, Township and Range; thence  
 run North with the East line of said Lot 6 a distance of one  
 thousand and twenty (1020) feet; thence run Westerly two  
 hundred sixty-six (266) feet for the point of beginning;  
 thence continue Westerly three hundred ninety-four (394)  
 feet; thence run North one hundred fifty (150) feet; thence  
 run Easterly three hundred ninety-four (394) feet; thence  
 run Southerly one hundred fifty (150) feet to the point of  
 beginning, all lying and being in the above County.

DOCUMENTARY  
 SUR TAX  
 00.55

FLORIDA  
 JUL-375  
 DEPT. OF REVENUE  
 P.B. 11114



189600  
 ESCAMBIA  
 COUNTY

ESCAMBIA  
 COUNTY  
 00201  
 STATE OF FLORIDA  
 DOCUMENTARY STAMP TAX  
 DEPT. OF REVENUE  
 JUL-375  
 00.30

JUL 1 1 57 PM '75  
 IN BOOTH ABOVE  
 JOE A. FLOWERS, COMPTROLLER  
 ESCAMBIA COUNTY

FILED & RECORDED IN  
 THE PUBLIC RECORDS OF  
 ESCAMBIA COUNTY FLA. ON

682774

**To Have and to Hold** the same together with all and singular the appurtenances thereunto  
 belonging or in anywise appertaining, and all the estate, right, title, interest, lien, equity and claim what-  
 soever of the said first party, either in law or equity, to the only proper use, benefit and behoof of the said  
 second party forever.

**In Witness Whereof**, The said first party has signed and sealed these presents the day and year  
 first above written.  
 Signed, sealed and delivered in presence of:

KATHRYN L. GATTERDAM  
 Marcia P. Warren

X  
 Roxanne R. P. [Signature]

STATE OF FLORIDA,  
 COUNTY OF Escambia

I HEREBY CERTIFY that on this day, before me, an  
 officer duly authorized in the State aforesaid and in the County aforesaid to take acknowledgments, personally appeared  
 Marcia P. Warren, a divorced and unremarried woman

to me known to be the person described in and who executed the foregoing instrument and who acknowledged  
 before me that she executed the same.

WITNESS my hand and official seal in the County and State last aforesaid this 14th day of  
 June A. D. 19 75.

[Signature]  
 Notary Public  
 My Commission expires June 21, 1977

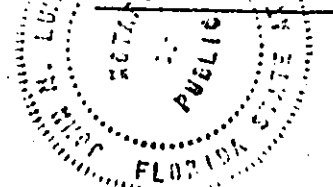

This Instrument prepared by: E. N. Stephens, Jr.  
 Address Suite 130, 200 E. Government Street  
 Pensacola, Florida 32501

OR BK 4315 PG1526  
Escambia County, Florida  
INSTRUMENT 98-530050  
RCD Oct 05, 1998 09:44 am  
Escambia County, Florida

NOTICE OF LIEN

Ernie Lee Magaha  
Clerk of the Circuit Court  
INSTRUMENT 98-530050

STATE OF FLORIDA  
COUNTY OF ESCAMBIA

FIRE PROTECTION MUNICIPAL SERVICE BENEFIT UNIT (MSBU)

Re: WARREN DENNIS  
1815 N 58TH AVE  
PENSACOLA FL 32506

ACCT.NO. 05 4401 000 000  
AMOUNT \$174.33

THIS Notice of Lien is hereby filed pursuant to Section 1-15-63 of the Escambia County, Florida Code of Ordinances for delinquent annual assessments for fiscal years prior to and including September 30, 1998 plus a 10% penalty charge against real property, more particularly described as:

BEG AT SE COR OF LT 6 N ALG  
E LI 1020 FT W 266 FT FOR  
POB CONTINUE W 394 FT N  
150 FT E 394 FT S 150 FT  
TO POB OR 813 P 689  
OR 913 P 196  
PROP.NO. 14 2S 30 6101 000 055

filed in the public records of Escambia County. This constitutes a lien against the property identified above until discharged and satisfied by payment to the Clerk of the Circuit Court of the lien, plus penalties, in the total amount of \$174.33. Evidence of discharge and satisfaction of this lien can be recorded in the public records of Escambia County, Florida by the Clerk of the Circuit Court.

This lien shall not be assigned to any person. Until fully satisfied by payment, discharged or barred by law, this lien shall remain equal in rank and dignity with the liens of all state, county, district or municipal taxes and special assessments and superior in rank and dignity to all other subsequently filed liens, encumbrances, titles and claims in, to, or against the property. This lien may be enforced at any time by the Board of County Commissioners subsequent to the date of recording of this Notice of Lien for the amount due under the recorded lien, including all penalties, plus costs and a reasonable attorney's fee by proceedings in a court of equity to fore-close liens in the manner in which a mortgage lien is foreclosed or under the provisions of Chapter 173, Florida Statutes or the collection and enforcement of payment thereof may be accomplished by any other method authorized by law.

Date: 09/04/1998

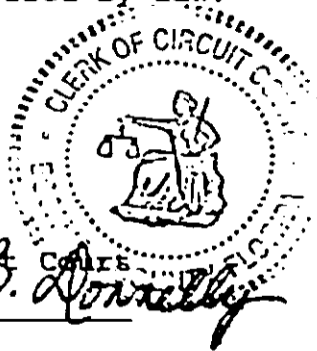

Ernie Lee Magaha  
Clerk of the Circuit Court  
by: *[Signature]*  
Deputy Finance Director

Ernie Lee Magaha  
Clerk of the Circuit Court  
by: *[Signature]*  
Deputy Clerk



147 38163 006

DR BK 4447 P60145  
Escambia County, Florida  
INSTRUMENT 99-638362  
RCD Aug 03, 1999 10:50 am  
Escambia County, Florida

NOTICE OF LIEN

STATE OF FLORIDA  
COUNTY OF ESCAMBIA

Ernie Lee Magaha  
Clerk of the Circuit Court  
INSTRUMENT 99-638362

FIRE PROTECTION MUNICIPAL SERVICE BENEFIT UNIT (MSBU)

Re: WARREN DENNIS  
1815 N 58TH AVE  
PENSACOLA FL 32506

ACCT.NO. 05 4401 000 000  
AMOUNT \$29.92

THIS Notice of Lien is hereby filed pursuant to Section 1-15-63 of the Escambia County, Florida Code of Ordinances for delinquent annual assessments for the fiscal year October 1, 1998 through September 30, 1999 plus a 10% penalty charge against real property, more particularly described as:

BEG AT SE COR OF LT 6 N ALG  
E LI 1020 FT W 266 FT FOR  
POB CONTINUE W 394 FT N  
150 FT E 394 FT S 150 FT  
TO POB OR 813 P 689  
OR 913 P 196  
PROP.NO. 14 2S 30 6101 000 055

filed in the public records of Escambia County. This constitutes a lien against the property identified above until discharged and satisfied by payment to the Clerk of the Circuit Court of the lien, plus penalties, in the total amount of \$29.92. Evidence of discharge and satisfaction of this lien can be recorded in the public records of Escambia County, Florida by the Clerk of the Circuit Court.

This lien shall not be assigned to any person. Until fully satisfied by payment, discharged or barred by law, this lien shall remain equal in rank and dignity with the liens of all state, county, district or municipal taxes and special assessments and superior in rank and dignity to all other subsequently filed liens, encumbrances, titles and claims in, to, or against the property. This lien may be enforced at any time by the Board of County Commissioners subsequent to the date of recording of this Notice of Lien for the amount due under the recorded lien, including all penalties, plus costs and a reasonable attorney's fee by proceedings in a court of equity to foreclose liens in the manner in which a mortgage lien is foreclosed or under the provisions of Chapter 717, Florida Statutes or the collection and enforcement of payment thereof may be accomplished by any other method authorized by law.

Date: 05/24/1999



Ernie Lee Magaha  
Clerk of the Circuit Court  
by *Wanda M. McCreary*  
Wanda M. McCreary  
Deputy Finance Director

Ernie Lee Magaha  
Clerk of the Circuit Court  
by *Barbara B. Donnelly*  
Deputy Clerk

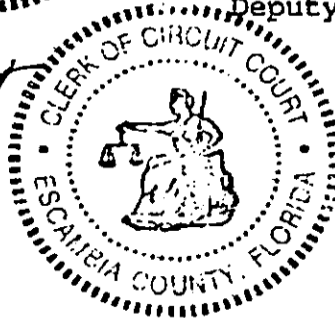

THE OFFICE OF ENVIRONMENTAL CODE ENFORCEMENT  
SPECIAL MASTER  
IN AND FOR THE  
COUNTY OF ESCAMBIA, STATE OF FLORIDA

ESCAMBIA COUNTY, FLORIDA

Vs.

Case No.: 2000-05-0263  
Location: 1815 N. 58th Ave.

Dennis Warren  
1815 N. 58th Ave.  
Pensacola, FL 32506

O R D E R

This CAUSE having come before the Office of  
Environmental Code Enforcement Special Master on the Petition of  
the Environmental Code Enforcement Officer for alleged violation  
of the ordinances of the County of Escambia, State of Florida, and  
the Special Master having considered the evidence before it, and  
the appropriate sections of the Escambia County Code of  
Ordinances, the Special Master makes the following findings of  
fact and conclusions of law:

- A violation of the following ordinance(s) has occurred:  
Code 42-114 (2) (4)
- A violation of the ordinance(s) as set forth in the  
Petition has not occurred.

THEREFORE, The Special Master being otherwise fully  
advised in the premises; it is hereby

ORDERED that: Dennis Warren  
shall have until August 3, 2001 to correct the violation  
and to bring the violation into compliance.

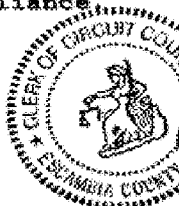
 Certified to be a true copy  
 the original on file in this office  
 by my hand and official seal  
 ERNIE LEE MAGAHA  
 Clerk of the Circuit Court  
 Escambia County, Florida  
 Date 5/12/2008

Correction shall include:

1. Removal of + proper storage of inoperable vehicle/boat  
3-4 beach buggies, car + van in front yard.

2. Removal of + proper storage of debris on porch in  
side yard

3. Keep front + sides of yards free of inoperable  
vehicles, trash + debris

IF you fail to fully correct the violation within the time required, you will be assessed a fine of \$25.<sup>00</sup> per day, commencing August 4 2001. This daily fine shall continue until this violation is abated and the violation brought into compliance or until as otherwise provided by law. Immediately upon your full correction of this violation, you should contact the Escambia County code Enforcement Office in writing to request that they immediately inspect the property to make an official determination of whether the violation has been abated and brought into compliance.

If the violation is not abated within the specified time period, then the County may elect to abate the violation for you and the reasonable cost of such will be assessed against you and will constitute a lien on the your property.

Costs in the amount of \$675.00 are hereby awarded in favor of Escambia County as the prevailing party against

Dennis Warren

These costs will be suspended and will not be assessed



against you if you fully cure the violation within the time provided above.

\_\_\_\_\_ presents a serious threat to the public health, safety and welfare.

\_\_\_\_\_ is irreparable or irreversible in nature and, as such, under Florida Statutes 162.09(2)(a), the fine shall not exceed \$5,000.00

This fine shall be forwarded to the Board of County Commissioners. Under the authority of 162.09(1), F.S. and Sec. 30-34(d) of the Code of Ordinances, the Board of County Commissioners may make all reasonable repairs necessary to bring the property into compliance if the violator does not correct the violation by a specified date. The costs of such repairs shall be certified to the Special Master and may be added to any fines imposed pursuant to this order.

All monies owing hereunder shall constitute a lien on all your real and personal property including any property involved herein, which lien can be enforced by foreclosure and as provided by law.

You have the right to appeal this order to the Circuit Court of Escambia County. If you wish to appeal, you must give notice of such in writing to both the Environmental Code Enforcement Division at 1190 West Leonard Street, Pensacola, Florida 32501 and the Escambia County Circuit Court Clerk at the M.C. Blanchard Judicial Building, 190 Governmental Center, Pensacola, Florida 32501, no later than 30 days from the date of this Order. Failure to timely file a written Notice of Appeal will waive your rights to appeal.

Jurisdiction is retained to enter such further orders as may be appropriate and necessary.

DONE AND ORDERED at Escambia County, Florida on this  
the 3rd day of July, 2001

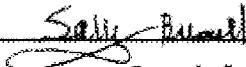
  
\_\_\_\_\_  
Special Master  
Office of Environmental Code Enforcement

Recorded in Public Records 7/24/2017 10:18 AM OR Book 7748 Page 777,  
Instrument #2017055894, Pam Childers Clerk of the Circuit Court Escambia  
County, FL Recording \$44.00

THE OFFICE OF ENVIRONMENTAL ENFORCEMENT  
SPECIAL MAGISTRATE  
IN AND FOR THE  
COUNTY OF ESCAMBIA, STATE OF FLORIDA

PETITIONER  
ESCAMBIA COUNTY FLORIDA,

VS.

CASE NO: CE#16-01-00124  
LOCATION: 1815 N 58<sup>th</sup> Ave  
PR# 142S30610100055

Warren Dennis  
3499 N Alcaniz St  
Pensacola, FL 32503  
RESPONDENT

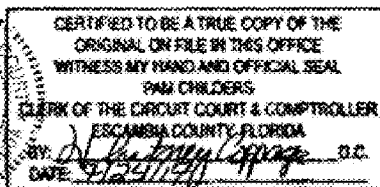

ORDER

This CAUSE having come before the Office of Environmental Enforcement Special Magistrate on the Petition of the Environmental Enforcement Officer for alleged violation of the ordinances of the County of Escambia, State of Florida, and the Special Magistrate having considered the evidence before him in the form of testimony by the Enforcement Officer and the Respondent or representative, thereof, N/A, as well as evidence submitted and after consideration of the appropriate sections of the Escambia County Code of Ordinances, the Special Magistrate finds that a violation of the following Code of Ordinance(s) has occurred and continues

- 42-196 (a) Nuisance Conditions
- 42-196 (b) Trash and Debris
- 42-196 (c) Inoperable Vehicle(s); Described \_\_\_\_\_
- 42-196 (d) Overgrowth

30-203 Unsafe Building; Described as  Main Structure  Accessory Building(s)  
 (a)  (b)  (c)  (d)  (e)  (f)  (g)  (h)  (i)  (j)  (k)  (l)  (m)  (n)  (o)  
 (p)  (q)  (r)  (s)  (t)  (u)  (v)  (w)  (x)  (y)  (z)  (aa)  (bb)  (cc)  (dd)

94-51 Obstruction of County Right-of-Way (ROW)

82-171 Mandatory Residential Waste Collection

82-15 Illegal Burning

82-5 Littering Prohibited

LDC Chapter 3 Commercial in residential and non permitted use

LDC Chapter 2 Article 3 Land Disturbance without permits

LDC Chapter 5 Article 8 Prohibited Signs, Un-permitted Sign ROW

LDC Sec 4-7.9 Outdoor Storage trash, boats, appliances

Other 3-2.7 MDR Does not allow outside

Other STORAGE

Other \_\_\_\_\_

Other \_\_\_\_\_

Other \_\_\_\_\_

THEREFORE, The Special Magistrate being otherwise fully advised in  
the premises; it is hereby **ORDERED** that **RESPONDENT** shall have until 8/1  
**2017** to correct the violation and to bring the violation into compliance.

Corrective action shall include:

- Complete removal of all contributing nuisance conditions; trash, rubbish, overgrowth and legally dispose of. Maintain clean conditions to avoid a repeat violation.
- Remove vehicle. Repair vehicle or store in rear yard behind 6' opaque fencing
- Obtain building permit and restore structure to current building codes or, obtain demolition permit and remove the structure(s), legally disposing of all debris.
- Remove all structures, signs, vehicles, etc. from County ROW; refrain from further obstruction.
- Subscribe for residential waste collection with a legal waste collection service and comply with solid waste disposal methods
- Immediately cease burning and refrain from future burning
- Remove all refuse and dispose of legally and refrain from future littering
- Rezone property and conform to all performance standards or complete removal of the commercial or industrial entity
- Obtain necessary permits or cease operations
- Acquire proper permits or remove sign(s)
- Other CURSE OUTSIDE STORAGE
- Other \_\_\_\_\_
- Other \_\_\_\_\_
- Other \_\_\_\_\_
- Other \_\_\_\_\_

BK: 7748 PG: 780

If you fail to fully correct the violation within the time required, you will be assessed a fine of \$ 28 . 00 per day, commencing 8/2, 2017. This daily fine shall continue until this violation is abated and the violation brought into compliance or until as otherwise provided by law. **YOU ARE REQUIRED,** immediately upon your full correction of this violation(s), to contact the Escambia County Environmental Enforcement Office in writing to request that they immediately inspect the property to make an official determination of whether the violation has been abated and brought into compliance. If the violation is not abated within the specified time period, then the County may elect to take whatever measures are necessary to abate the violation for you. These measures could include, but are not limited to, **DEMOLISHING YOUR STRUCTURE (S), LEGALLY DISPOSING OF ALL CONTRIBUTING CONDITIONS, AND TOWING OF DESCRIBED VEHICLE (S).** The reasonable cost of such will be assessed against you and will constitute a lien on the property.

Costs in the amount of \$ 1,100.00 are awarded in favor of Escambia County as the prevailing party against **RESPONDENT.**

This fine shall be forwarded to the Board of County Commissioners. Under the authority of 162.09(1) F.S. and Sec. 30-34(d) of the Code of Ordinances, the Board of County Commissioners will certify to the Special Magistrate all costs imposed pursuant to this order. All Monies owing hereunder shall constitute a lien on **ALL YOUR REAL AND PERSONAL PROPERTY** including any property involved herein, which lien can be enforced by foreclosure and as provided by law.

**BK: 7748 PG: 781 Last Page**

**You have the right** to appeal orders of the Special Magistrate to the Circuit Court of Escambia County. If you wish to appeal, you must give notice of such in writing to both the Environmental Enforcement Division at 3363 W Park Place, Pensacola, Florida 32505 and the Escambia County Circuit Court at the M.C. Blanchard Judicial Building, 190 Governmental Center, Pensacola, Florida 32501, no later than **30 days** from the date of this Order. Failure to timely file a Written Notice of Appeal will waive your rights to appeal.

Jurisdiction is retained to enter such further orders as may be appropriate and necessary.

**DONE AND ORDERED** at Escambia County, Florida on the 11<sup>th</sup> day of July, 2017.

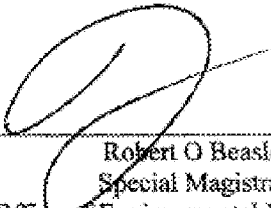
  
\_\_\_\_\_  
Robert O Beasley  
Special Magistrate  
Office of Environmental Enforcement

STATE OF FLORIDA  
COUNTY OF ESCAMBIA

CERTIFICATE OF NOTICE OF MAILING  
NOTICE OF APPLICATION FOR TAX DEED

CERTIFICATE # 02343 of 2022

I, PAM CHILDERS, CLERK OF THE CIRCUIT COURT OF ESCAMBIA COUNTY, FLORIDA, do hereby certify that I did on August 15, 2024, mail a copy of the foregoing Notice of Application for Tax Deed, addressed to:

DENNIS WARREN 3499 N ALCANIZ ST PENSACOLA, FL 32503	DENNIS O. WARREN 1815 N. 58TH AVE PENSACOLA, FL 32503	
ESCAMBIA COUNTY / COUNTY ATTORNEY 221 PALAFOX PLACE STE 430 PENSACOLA FL 32502		ESCAMBIA COUNTY OFFICE OF CODE ENFORCEMENT ESCAMBIA CENTRAL OFFICE COMPLEX 3363 WEST PARK PLACE PENSACOLA FL 32505

WITNESS my official seal this 15th day of August 2024.

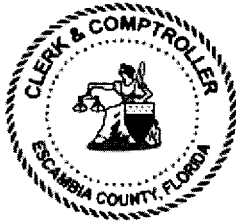

PAM CHILDERS  
CLERK OF THE CIRCUIT COURT  
ESCAMBIA COUNTY, FLORIDA

By:  
Emily Hogg  
Deputy Clerk



## WARNING

THERE ARE UNPAID TAXES ON PROPERTY WHICH YOU OWN OR IN WHICH YOU HAVE A LEGAL INTEREST. THE PROPERTY WILL BE SOLD AT PUBLIC AUCTION ON October 2, 2024, UNLESS THE TAXES ARE PAID. SHOULD YOU NEED FURTHER INFORMATION CONTACT THE CLERK OF THE CIRCUIT COURT IMMEDIATELY AT THE COUNTY COURTHOUSE IN PENSACOLA, FLORIDA, OR CALL 850-595-3793.

## NOTICE OF APPLICATION FOR TAX DEED

NOTICE IS HEREBY GIVEN, That ASSEMBLY TAX 36 LLC holder of Tax Certificate No. 02343, issued the 1st day of June, A.D., 2022 has filed same in my office and has made application for a tax deed to be issued thereon. Said certificate embraces the following described property in the County of Escambia, State of Florida, to wit:

**BEG AT SE COR OF LT 6 N ALG E LI 1020 FT W 266 FT FOR POB CONTINUE W 394 FT N 150 FT E 394 FT S 150 FT TO POB OR 813 P 689 OR 913 P 196 LTS 55 56 OF AN UNRECORDED PLAT**

**SECTION 14, TOWNSHIP 2 S, RANGE 30 W**

**TAX ACCOUNT NUMBER 054401000 (1024-19)**

The assessment of the said property under the said certificate issued was in the name of

**DENNIS WARREN**

Unless said certificate shall be redeemed according to law, the property described therein will be sold to the highest bidder at public auction at 9:00 A.M. on the **first** Wednesday in the month of October, which is the **2nd day of October 2024**.

Dated this 16th day of August 2024.

In accordance with the AMERICANS WITH DISABILITIES ACT, if you are a person with a disability who needs special accommodation in order to participate in this proceeding you are entitled to the provision of certain assistance. Please contact Emily Hogg not later than seven days prior to the proceeding at Escambia County Government Complex, 221 Palafox Place Ste 110, Pensacola FL 32502. Telephone: 850-595-3793.



**PAM CHILDERS  
CLERK OF THE CIRCUIT COURT  
ESCAMBIA COUNTY, FLORIDA**

By:  
Emily Hogg  
Deputy Clerk

DENNIS WARREN [1024-19]  
3499 N ALCANIZ ST  
PENSACOLA, FL 32503

9171 9690 0935 0127 1778 04

DENNIS O. WARREN [1024-19]  
1815 N. 58TH AVE  
PENSACOLA, FL 32503

9171 9690 0935 0127 1777 98

ESCAMBIA COUNTY / COUNTY  
ATTORNEY [1024-19]  
221 PALAFOX PLACE STE 430  
PENSACOLA FL 32502

9171 9690 0935 0127 1777 81

ESCAMBIA COUNTY OFFICE OF CODE  
ENFORCEMENT [1024-19]  
ESCAMBIA CENTRAL OFFICE COMPLEX  
3363 WEST PARK PLACE  
PENSACOLA FL 32505

9171 9690 0935 0127 1777 74

## WARNING

THERE ARE UNPAID TAXES ON PROPERTY WHICH YOU OWN OR IN WHICH YOU HAVE A LEGAL INTEREST. THE PROPERTY WILL BE SOLD AT PUBLIC AUCTION ON **October 2, 2024**, UNLESS THE TAXES ARE PAID. SHOULD YOU NEED FURTHER INFORMATION CONTACT THE CLERK OF THE CIRCUIT COURT IMMEDIATELY AT THE COUNTY COURTHOUSE IN PENSACOLA, FLORIDA, OR CALL 850-595-3793.

## NOTICE OF APPLICATION FOR TAX DEED

NOTICE IS HEREBY GIVEN, That **ASSEMBLY TAX 36 LLC** holder of **Tax Certificate No. 02343**, issued the **1st** day of **June, A.D., 2022** has filed same in my office and has made application for a tax deed to be issued thereon. Said certificate embraces the following described property in the County of Escambia, State of Florida, to wit:

**BEG AT SE COR OF LT 6 N ALG E LI 1020 FT W 266 FT FOR POB CONTINUE W 394 FT N 150 FT E 394 FT S 150 FT TO POB OR 813 P 689 OR 913 P 196 LTS 55 56 OF AN UNRECORDED PLAT**

**SECTION 14, TOWNSHIP 2 S, RANGE 30 W**

**TAX ACCOUNT NUMBER 054401000 (1024-19)**

The assessment of the said property under the said certificate issued was in the name of

**DENNIS WARREN**

Unless said certificate shall be redeemed according to law, the property described therein will be sold to the highest bidder at public auction at 9:00 A.M. on the **first** Wednesday in the month of October, which is the **2nd** day of **October 2024**.

Dated this 15th day of August 2024.

In accordance with the AMERICANS WITH DISABILITIES ACT, if you are a person with a disability who needs special accommodation in order to participate in this proceeding you are entitled to the provision of certain assistance. Please contact Emily Hogg not later than seven days prior to the proceeding at Escambia County Government Complex, 221 Palafox Place Ste 110, Pensacola FL 32502. Telephone: 850-595-3793.

### Post Property:

1815 N 58TH AVE 32506



PAM CHILDERS  
CLERK OF THE CIRCUIT COURT  
ESCAMBIA COUNTY, FLORIDA

By:  
Emily Hogg  
Deputy Clerk

## WARNING

THERE ARE UNPAID TAXES ON PROPERTY WHICH YOU OWN OR IN WHICH YOU HAVE A LEGAL INTEREST. THE PROPERTY WILL BE SOLD AT PUBLIC AUCTION ON October 2, 2024, UNLESS THE TAXES ARE PAID. SHOULD YOU NEED FURTHER INFORMATION CONTACT THE CLERK OF THE CIRCUIT COURT IMMEDIATELY AT THE COUNTY COURTHOUSE IN PENSACOLA, FLORIDA, OR CALL 850-595-3793.

## NOTICE OF APPLICATION FOR TAX DEED

NOTICE IS HEREBY GIVEN, That ASSEMBLY TAX 36 LLC holder of Tax Certificate No. 02343, issued the 1st day of June, A.D., 2022 has filed same in my office and has made application for a tax deed to be issued thereon. Said certificate embraces the following described property in the County of Escambia, State of Florida, to wit:

**BEG AT SE COR OF LT 6 N ALG E LI 1020 FT W 266 FT FOR POB CONTINUE W 394 FT N 150 FT E 394 FT S 150 FT TO POB OR 813 P 689 OR 913 P 196 LTS 55 56 OF AN UNRECORDED PLAT**

**SECTION 14, TOWNSHIP 2 S, RANGE 30 W**

**TAX ACCOUNT NUMBER 054401000 (1024-19)**

The assessment of the said property under the said certificate issued was in the name of

**DENNIS WARREN**

Unless said certificate shall be redeemed according to law, the property described therein will be sold to the highest bidder at public auction at 9:00 A.M. on the **first** Wednesday in the month of October, which is the **2nd** day of **October 2024**.

Dated this 15th day of August 2024.

In accordance with the AMERICANS WITH DISABILITIES ACT, if you are a person with a disability who needs special accommodation in order to participate in this proceeding you are entitled to the provision of certain assistance. Please contact Emily Hogg not later than seven days prior to the proceeding at Escambia County Government Complex, 221 Palafox Place Ste 110, Pensacola FL 32502. Telephone: 850-595-3793.

### Personal Services:

**DENNIS WARREN**  
3499 N ALCANIZ ST  
PENSACOLA, FL 32503

PAM CHILDERS  
CLERK OF THE CIRCUIT COURT  
ESCAMBIA COUNTY, FLORIDA



By:  
Emily Hogg  
Deputy Clerk

ESCAMBIA COUNTY SHERIFF'S OFFICE  
ESCAMBIA COUNTY, FLORIDA

**NON-ENFORCEABLE RETURN OF SERVICE**

1024-19

**Document Number:** ECSO24CIV029152NON

**Agency Number:** 24-008944

**Court:** TAX DEED

**County:** ESCAMBIA

**Case Number:** CERT NO 02343 2022

**Attorney/Agent:**

PAM CHILDERS  
CLERK OF COURT  
TAX DEED

**Plaintiff:** RE: DENNIS WARREN

**Defendant:**

**Type of Process:** NOTICE OF APPLICATION FOR TAX DEED

Received this Writ on 8/23/2024 at 9:09 AM and served same at 9:20 AM on 8/28/2024 in ESCAMBIA COUNTY, FLORIDA, by serving POST PROPERTY , the within named, to wit: , .

POSTED TO THE PROPERTY AS INSTRUCTED BY THE CLERKS OFFICE

CHIP W SIMMONS, SHERIFF  
ESCAMBIA COUNTY, FLORIDA

By:  928

A. DUDA, CPS

Service Fee: \$40.00

Receipt No: BILL

Printed By: LCMITCHE

## WARNING

THERE ARE UNPAID TAXES ON PROPERTY WHICH YOU OWN OR IN WHICH YOU HAVE A LEGAL INTEREST. THE PROPERTY WILL BE SOLD AT PUBLIC AUCTION ON **October 2, 2024**, UNLESS THE TAXES ARE PAID. SHOULD YOU NEED FURTHER INFORMATION CONTACT THE CLERK OF THE CIRCUIT COURT IMMEDIATELY AT THE COUNTY COURTHOUSE IN PENSACOLA, FLORIDA, OR CALL 850-595-3793.

## NOTICE OF APPLICATION FOR TAX DEED

NOTICE IS HEREBY GIVEN, That **ASSEMBLY TAX 36 LLC** holder of **Tax Certificate No. 02343**, issued the **1st** day of **June, A.D., 2022** has filed same in my office and has made application for a tax deed to be issued thereon. Said certificate embraces the following described property in the County of Escambia, State of Florida, to wit:

**BEG AT SE COR OF LT 6 N ALG E LI 1020 FT W 266 FT FOR POB CONTINUE W 394 FT N 150 FT E 394 FT S 150 FT TO POB OR 813 P 689 OR 913 P 196 LTS 55 56 OF AN UNRECORDED PLAT**

**SECTION 14, TOWNSHIP 2 S, RANGE 30 W**

**TAX ACCOUNT NUMBER 054401000 (1024-19)**

The assessment of the said property under the said certificate issued was in the name of

**DENNIS WARREN**

Unless said certificate shall be redeemed according to law, the property described therein will be sold to the highest bidder at public auction at 9:00 A.M. on the **first** Wednesday in the month of October, which is the **2nd** day of **October 2024**.

Dated this 15th day of August 2024.

In accordance with the AMERICANS WITH DISABILITIES ACT, if you are a person with a disability who needs special accommodation in order to participate in this proceeding you are entitled to the provision of certain assistance. Please contact Emily Hogg not later than seven days prior to the proceeding at Escambia County Government Complex, 221 Palafox Place Ste 110, Pensacola FL 32502. Telephone: 850-595-3793.

**Post Property:**

1815 N 58TH AVE 32506

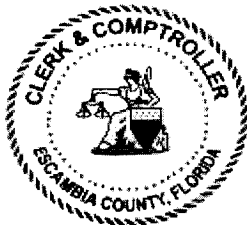

**PAM CHILDERS**  
**CLERK OF THE CIRCUIT COURT**  
**ESCAMBIA COUNTY, FLORIDA**

By:  
Emily Hogg  
Deputy Clerk

ESCAMBIA COUNTY SHERIFF'S OFFICE  
ESCAMBIA COUNTY, FLORIDA

**NON-ENFORCEABLE RETURN OF SERVICE** 1024-19

**Document Number:** ECSO24CIV029161NON

**Agency Number:** 24-008947

**Court:** TAX DEED

**County:** ESCAMBIA

**Case Number:** CERT NO 02343 2022

**Attorney/Agent:**

PAM CHILDERS  
CLERK OF COURT  
TAX DEED

**Plaintiff:** RE: DENNIS WARREN

**Defendant:**

**Type of Process:** NOTICE OF APPLICATION FOR TAX DEED

Non-Executed

Received this Writ on 8/23/2024 at 9:09 AM and after a diligent search in ESCAMBIA COUNTY, FLORIDA for DENNIS WARREN , Writ was returned to court UNEXECUTED on 9/5/2024 for the following reason:

GIVEN ADDRESS APPEARS TO BE A STORAGE BUSINESS; GATE LOCKED. SUBJECT IS DECEASED. NO ADDITIONAL INFORMATION GAINED THROUGH DUE DILIGENCE EFFORTS.

CHIP W SIMMONS, SHERIFF  
ESCAMBIA COUNTY, FLORIDA

By: \_\_\_\_\_

*J. Carnley 926*  
J. CARNLEY, CPS

Service Fee: \$40.00

Receipt No: BILL

Printed By: LCMITCHE

# WARNING

THERE ARE UNPAID TAXES ON PROPERTY WHICH YOU OWN OR IN WHICH YOU HAVE A LEGAL INTEREST. THE PROPERTY WILL BE SOLD AT PUBLIC AUCTION ON October 2, 2024, UNLESS THE TAXES ARE PAID. SHOULD YOU NEED FURTHER INFORMATION CONTACT THE CLERK OF THE CIRCUIT COURT IMMEDIATELY AT THE COUNTY COURTHOUSE IN PENSACOLA, FLORIDA, OR CALL 850-595-3793.

## NOTICE OF APPLICATION FOR TAX DEED

NOTICE IS HEREBY GIVEN, That **ASSEMBLY TAX 36 LLC** holder of **Tax Certificate No. 02343**, issued the **1st** day of **June, A.D., 2022** has filed same in my office and has made application for a tax deed to be issued thereon. Said certificate embraces the following described property in the County of Escambia, State of Florida, to wit:

**BEG AT SE COR OF LT 6 N ALG E LI 1020 FT W 266 FT FOR POB CONTINUE W 394 FT N 150 FT E 394 FT S 150 FT TO POB OR 813 P 689 OR 913 P 196 LTS 55 56 OF AN UNRECORDED PLAT**

**SECTION 14, TOWNSHIP 2 S, RANGE 30 W**

**TAX ACCOUNT NUMBER 054401000 (1024-19)**

The assessment of the said property under the said certificate issued was in the name of

**DENNIS WARREN**

Unless said certificate shall be redeemed according to law, the property described therein will be sold to the highest bidder at public auction at 9:00 A.M. on the **first** Wednesday in the month of October, which is the **2nd** day of **October 2024**.

Dated this 15th day of August 2024.

In accordance with the AMERICANS WITH DISABILITIES ACT, if you are a person with a disability who needs special accommodation in order to participate in this proceeding you are entitled to the provision of certain assistance. Please contact Emily Hogg not later than seven days prior to the proceeding at Escambia County Government Complex, 221 Palafox Place Ste 110, Pensacola FL 32502. Telephone: 850-595-3793.

### Personal Services:

**DENNIS WARREN**  
3499 N ALCANIZ ST  
PENSACOLA, FL 32503

**PAM CHILDERS**  
CLERK OF THE CIRCUIT COURT  
ESCAMBIA COUNTY, FLORIDA

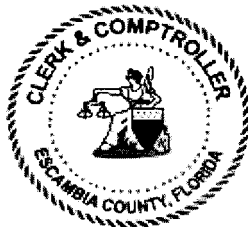

By:  
Emily Hogg  
Deputy Clerk

10/2/24  
2024-10-02 10:00 AM  
10/2/24



# WARNING

THERE ARE UNPAID TAXES ON PROPERTY WHICH YOU OWN OR IN WHICH YOU HAVE A LEGAL INTEREST. THE PROPERTY WILL BE SOLD AT PUBLIC AUCTION ON October 2, 2024, UNLESS THE TAXES ARE PAID. SHOULD YOU NEED FURTHER INFORMATION CONTACT THE CLERK OF THE CIRCUIT COURT IMMEDIATELY AT THE COUNTY COURTHOUSE IN PENSACOLA, FLORIDA, OR CALL 850-595-3793.

## NOTICE OF APPLICATION FOR TAX DEED

NOTICE IS HEREBY GIVEN, That ASSEMBLY TAX 36 LLC holder of Tax Certificate No. 02343, issued the 1st day of June, A.D., 2022 has filed same in my office and has made application for a tax deed to be issued thereon. Said certificate embraces the following described property in the County of Escambia, State of Florida, to wit:

BEG AT SE COR OF LT 6 N ALG E LI 1020 FT W 266 FT FOR POB CONTINUE W 394 FT N 150 FT E 394 FT S 150 FT TO POB OR 813 P 689 OR 913 P 196 LTS 55 56 OF AN UNRECORDED PLAT

SECTION 14, TOWNSHIP 2 S, RANGE 30 W

TAX ACCOUNT NUMBER 054401000 (1024-19) 1815 H 58<sup>th</sup> Ave

The assessment of the said property under the said certificate issued was in the name of

**DENNIS WARREN**

Unless said certificate shall be redeemed according to law, the property described therein will be sold to the highest bidder at public auction at 9:00 A.M. on the first Wednesday in the month of October, which is the 2nd day of October 2024.

Dated this 15th day of August 2024.

In accordance with the AMERICANS WITH DISABILITIES ACT, if you are a person with a disability who needs special accommodation in order to participate in this proceeding you are entitled to the provision of certain assistance. Please contact Emily Hogg not later than seven days prior to the proceeding at Escambia County Government Complex, 221 Palafox Place Ste 110, Pensacola FL 32502. Telephone: 850-595-3793.

### Personal Services:

**DENNIS WARREN**  
3499 N ALCANIZ ST  
PENSACOLA, FL 32503

PAM CHILDERS  
CLERK OF THE CIRCUIT COURT  
ESCAMBIA COUNTY, FLORIDA

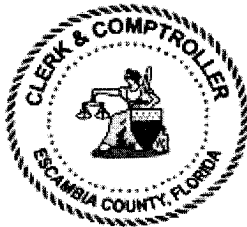

By:  
Emily Hogg  
Deputy Clerk

DENNIS WARREN [1024-19]  
3499 N ALCANIZ ST  
PENSACOLA, FL 32503

9171 9690 0935 0127 1778 04

DENNIS O. WARREN [1024-19]  
1815 N. 58TH AVE  
PENSACOLA, FL 32503

9171 9690 0935 0127 1777 98

ESCAMBIA COUNTY / COUNTY  
ATTORNEY [1024-19]  
221 PALAFOX PLACE STE 430  
PENSACOLA FL 32502

9171 9690 0935 0127 1777 81

ESCAMBIA COUNTY OFFICE OF CODE  
ENFORCEMENT [1024-19]  
ESCAMBIA CENTRAL OFFICE COMPLEX  
3363 WEST PARK PLACE  
PENSACOLA FL 32505

9171 9690 0935 0127 1777 74

Contact ~  
Family

**CERTIFIED MAIL™**



9171 9690 0935 0127 1777 98

PENSACOLA FL 325

25 AUG 2024 PM 1

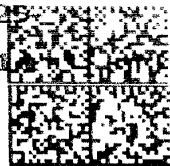

quadrant

FIRST-CLASS MAIL  
IM1

**\$008.16<sup>0</sup>**

08/22/2024 ZIP 32502  
043M31219251

US POSTAGE

**Pam Childers**  
Clerk of the Circuit Court & Comptroller  
Official Records  
221 Palafox Place, Suite 110  
Pensacola, FL 32502

RECEIVED  
10/17/24 10:30 AM  
CLERK OF THE CIRCUIT COURT  
OFFICIAL RECORDS  
221 PALAFOX PLACE  
PENSACOLA, FL 32502

DENNIS O. WARREN [1024-19]  
1815 N. 58TH AVE  
PENSACOLA, FL 32503

WTF

NIXIE

SEE FE 1

0000/29/24

RETURN TO SENDER  
NOT DELIVERABLE AS ADDRESSED  
UNABLE TO FORWARD

BC: 32502583335 \*2638-01088-22-36

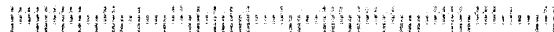

32502583335  
32502583335  
32502583335

POSTNET

**CERTIFIED MAIL™**

**Pam Childers**  
Clerk of the Circuit Court & Comptroller  
Official Records  
221 Palafox Place, Suite 110  
Pensacola, FL 32502



9171 0

PENSACOLA FL 32502  
AUG 22 10 24 PM 1

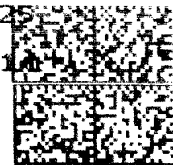

quadrant  
FIRST-CLASS MAIL  
IMI  
**\$008.16**  
08/22/2024 ZIP 32502  
043M31219251

US POSTAGE

*ML8624*

**UNCLAIM UNCLAIMED**

SEP 17 A 11:10  
PENSACOLA CITY, FL

*1024-19*

~~8-24~~  
~~8-19~~  
~~8-8~~

NIXIE 322 DE 1 0009/13/24

RETURN TO SENDER  
UNCLAIMED  
UNABLE TO FORWARD

32502-0570-0000  
32502-5833

BC: 32502583335 \*1087-02909-13-39

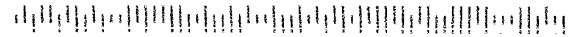

**PAM CHILDERS**  
CLERK OF THE CIRCUIT COURT  
ARCHIVES AND RECORDS  
CHILDSUPPORT  
CIRCUIT CIVIL  
CIRCUIT CRIMINAL  
COUNTY CIVIL  
COUNTY CRIMINAL  
DOMESTIC RELATIONS  
FAMILY LAW  
JURY ASSEMBLY  
JUVENILE  
MENTAL HEALTH  
MIS  
OPERATIONAL SERVICES  
PROBATE  
TRAFFIC



**BRANCH OFFICES**  
**ARCHIVES AND RECORDS**  
**JUVENILE DIVISION**  
**CENTURY**

CLERK TO THE BOARD OF  
COUNTY COMMISSIONERS  
OFFICIAL RECORDS  
COUNTY TREASURY  
AUDITOR

**COUNTY OF ESCAMBIA**  
**OFFICE OF THE**  
**CLERK OF THE CIRCUIT COURT**

**PAM CHILDERS, CLERK OF THE CIRCUIT COURT**  
**Tax Certificate Redeemed From Sale**  
**Account: 054401000 Certificate Number: 002343 of 2022**

**Payor: GLENDA WARREN 4348 BARCLAY PL PACE FL 32571 Date 9/18/2024**

Clerk's Check #	145971	Clerk's Total	\$497.04
Tax Collector Check #	1	Tax Collector's Total	\$7,586.09
		Postage	\$32.80
		Researcher Copies	\$0.00
		Recording	\$10.00
		Prep Fee	\$7.00
		Total Received	<del>\$8,132.93</del>

*8,132.93*

**PAM CHILDERS**  
Clerk of the Circuit Court

Received By: \_\_\_\_\_  
Deputy Clerk

A handwritten signature in black ink, appearing to be "Clerk", written over a horizontal line.

Escambia County Government Complex • 221 Palafox Place Ste 110 • PENSACOLA, FLORIDA 32502  
(850) 595-3793 • FAX (850) 595-4827 • <http://www.clerk.co.escambia.fl.us>

9/18/2024

---

# THE SUMMATION WEEKLY

---

A Weekly Publication of the Escambia-Santa Rosa Bar Association Since 2014

Before the undersigned authority personally appeared Malcolm Ballinger who under oath says that he is the Legal Administrator and Publisher of The Summation Weekly Newspaper published at Pensacola in Escambia & Santa Rosa County, Florida; that the attached copy of the advertisement, being a notice in the matter of

**2022 TD 02343 ASSEMBLY TAX 36 LLC Warren**

was published in said newspaper in and was printed and released from 8/28/2024 until 9/18/2024 for a consecutive 4 weeks.

Affiant further says that the said Summation Weekly is a newspaper published at Pensacola, in said Escambia & Santa Rosa Counties, Florida, and that the said newspaper has heretofore been continuously published in said Escambia & Santa Rosa Counties, Florida each week and has been entered as second class mail matter at the post office in Pensacola, in said Escambia County, Florida, for a period of one year next preceding the first publication of the attached copy of advertisement; and affiant further says that he has neither paid nor promised any person, firm or corporation any discount, rebate, commission or refund for the purpose of securing this advertisement for publication of the said newspaper.

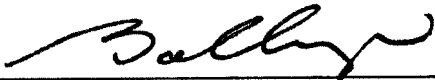
X   
MALCOLM BALLINGER,  
PUBLISHER FOR THE SUMMATION WEEKLY  
STATE OF FLORIDA COUNTY OF ESCAMBIA

The foregoing instrument was acknowledged before me by means of [X] physical presence or [ ] online notarization, on 9/18/2024, by MALCOLM BALLINGER, who is personally known to me.

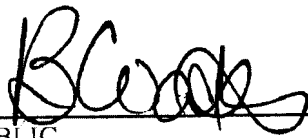
X   
NOTARY PUBLIC

 Brooklyn Faith Coates  
Notary Public  
State of Florida  
Comm# HH053675  
Expires 10/14/2024

# THE SUMMATION WEEKLY

A Weekly Publication of the Escambia-Santa Rosa Bar Association Since 2014

cont. Emily Hogg, Deputy Clerk; 2022 TD 02343 ASSEMBLY TAX 36 LLC Warren

Order No: 7343

**NOTICE OF APPLICATION FOR TAX DEED** By: Emily Hogg  
Deputy Clerk

NOTICE IS HEREBY GIVEN; That ASSEMBLY TAX 36 LLC holder of Tax Certificate No. 02343, issued the 1st day of June, A.D., 2022 has filed same in my office and has made application for a tax deed to be issued thereon. Said certificate embraces the following described property in the County of Escambia, State of Florida, to wit:

BEG AT SE COR OF LT 6 N ALG E LI 1020 FT W 266 FT FOR POB CONTINUE W 394 FT N 150 FT E 394 FT S 150 FT TO POB OR 813 P 689 OR 913 P 196 LTS 55 56 OF AN UNRECORDED PLAT

SECTION 14, TOWNSHIP 2 S, RANGE 30 W  
TAX ACCOUNT NUMBER 054401000  
(1024-19)

The assessment of the said property under the said certificate issued was in the name of

DENNIS WARREN

Unless said certificate shall be redeemed according to law, the property described therein will be sold to the highest bidder at public auction at 9:00 A.M. on the first Wednesday in the month of October, which is the 2nd day of October 2024.

Dated this 22nd day of August 2024.

In accordance with the AMERICANS WITH DISABILITIES ACT, if you are a person with a disability who needs special accommodation in order to participate in this proceeding you are entitled to the provision of certain assistance. Please contact Emily Hogg not later than seven days prior to the proceeding at Escambia County Government Complex, 221 Palafox Place Ste 110, Pensacola FL 32502. Telephone: 850-595-3793.

PAM CHILDERS  
CLERK OF THE CIRCUIT COURT  
ESCAMBIA COUNTY, FLORIDA

Name Emily Hogg, Deputy Clerk  
Order Number 7343  
Order Date 8/23/2024  
Number Issues 4  
Pub Count 1  
First Issue 8/28/2024  
Last Issue 9/18/2024  
Order Price \$200.00  
Publications The Summation Weekly

Emily Hogg, Deputy Clerk  
First Judicial Circuit, Escambia County  
190 W. Government St.  
Pensacola FL 32502  
USA