



CERTIFICATION OF TAX DEED APPLICATION

Sections 197.502 and 197.542, Florida Statutes

DR-513
Rule 12D-16.002 F.A.C
Effective 07/19
Page 1 of 2

Part 1: Tax Deed Application Information					
Applicant Name Applicant Address	KEYS FUNDING LLC - 9022 PO BOX 71540 PHILADELPHIA, PA 19176-1540	Application date	Apr 22, 2024		
Property description	ALLUA BRADFORD DWAYNE ALLUA CHRISTINE MARIE 2145 YARDLEY CIR PENSACOLA, FL 32526 2145 YARDLEY CIR 04-1925-109 LT 19 BLK B SOMERSET S/D PB 9 P 39 OR 8261 P 691	Certificate #	2022 / 1667		
		Date certificate issued	06/01/2022		
Part 2: Certificates Owned by Applicant and Filed with Tax Deed Application					
Column 1 Certificate Number	Column 2 Date of Certificate Sale	Column 3 Face Amount of Certificate	Column 4 Interest	Column 5: Total (Column 3 + Column 4)	
# 2022/1667	06/01/2022	2,127.52	106.38	2,233.90	
→ Part 2: Total*				2,233.90	
Part 3: Other Certificates Redeemed by Applicant (Other than County)					
Column 1 Certificate Number	Column 2 Date of Other Certificate Sale	Column 3 Face Amount of Other Certificate	Column 4 Tax Collector's Fee	Column 5 Interest	Total (Column 3 + Column 4 + Column 5)
# /					
Part 3: Total*					0.00
Part 4: Tax Collector Certified Amounts (Lines 1-7)					
1. Cost of all certificates in applicant's possession and other certificates redeemed by applicant (*Total of Parts 2 + 3 above)				2,233.90	
2. Delinquent taxes paid by the applicant				0.00	
3. Current taxes paid by the applicant				0.00	
4. Property information report fee				200.00	
5. Tax deed application fee				175.00	
6. Interest accrued by tax collector under s.197.542, F.S. (see Tax Collector Instructions, page 2)				0.00	
7. Total Paid (Lines 1-6)				2,608.90	
I certify the above information is true and the tax certificates, interest, property information report fee, and tax collector's fees have been paid, and that the property information statement is attached.					
Sign here:			Escambia, Florida		
Signature, Tax Collector or Designee			Date <u>April 24th, 2024</u>		

Send this certification to the Clerk of Court by 10 days after the date signed. See Instructions on Page 2

Part 5: Clerk of Court Certified Amounts (Lines 8-14)	
8. Processing tax deed fee	
9. Certified or registered mail charge	
10. Clerk of Court advertising, notice for newspaper, and electronic auction fees	
11. Recording fee for certificate of notice	
12. Sheriff's fees	
13. Interest (see Clerk of Court Instructions, page 2)	
14. Total Paid (Lines 8-13)	
15. Plus one-half of the assessed value of homestead property, if applicable under s. 197.502(6)(c), F.S.	106,802.50
16. Statutory opening bid (total of Lines 7, 14, 15, and 16 if applicable)	
Sign here: _____ Date of sale <u>04/02/2025</u> Signature, Clerk of Court or Designee	

INSTRUCTIONS + 6.25

Tax Collector (complete Parts 1-4)

Part 2: Certificates Owned by Applicant and Filed with Tax Deed Application

Enter the Face Amount of Certificate in Column 3 and the Interest in Column 4 for each certificate number. Add Columns 3 and 4 and enter the amount in Column 5.

Part 3: Other Certificates Redeemed by Applicant (Other than County)

Total. Add the amounts in Columns 3, 4 and 5

Part 4: Tax Collector Certified Amounts (Lines 1-7)

Line 1, enter the total of Part 2 plus the total of Part 3 above.

Total Paid, Line 7: Add the amounts of Lines 1-6

Line 6, Interest accrued by tax collector. Calculate the 1.5 percent interest accrued from the month after the date of application through the month this form is certified to the clerk. Enter the amount to be certified to the clerk on **Line 6**. The interest calculated by the tax collector stops before the interest calculated by the clerk begins. See Section 197.542, F.S., and Rule 12D-13.060(3), Florida Administrative Code.

The tax collector's interest for redemption at the time of the tax deed application is a cost of redemption, which encompasses various percentages of interest on certificates and omitted or delinquent taxes under Section 197.502, F.S. This interest is calculated before the tax collector calculates the interest in Section 197.542, F.S.

Attach certified statement of names and addresses of persons who must be notified before the sale of the property. Send this form and any required attachments to the Clerk of Court within 10 days after it is signed.

Clerk of Court (complete Part 5)

Line 13: Interest is calculated at the rate of 1.5 percent per month starting from the first day of the month after the month of certification of this form through the last day of the month in which the sale will be held. Multiply the calculated rate by the total of **Line 7**, minus **Line 6**, plus **Lines 8 through 12**. Enter the amount on **Line 13**.

Line 14: Enter the total of Lines 8-13. Complete Lines 15-18, if applicable.

APPLICATION FOR TAX DEED

Section 197.502, Florida Statutes

512
R. 12/16

Application Number: 2400590

To: Tax Collector of ESCAMBIA COUNTY, Florida

I,
KEYS FUNDING LLC - 9022
PO BOX 71540
PHILADELPHIA, PA 19176-1540,

hold the listed tax certificate and hereby surrender the same to the Tax Collector and make tax deed application thereon:

Account Number	Certificate No.	Date	Legal Description
04-1925-109	2022/1667	06-01-2022	LT 19 BLK B SOMERSET S/D PB 9 P 39 OR 8261 P 691

I agree to:

- pay any current taxes, if due and
- redeem all outstanding tax certificates plus interest not in my possession, and
- pay all delinquent and omitted taxes, plus interest covering the property.
- pay all Tax Collector's fees, property information report costs, Clerk of the Court costs, charges and fees, and Sheriff's costs, if applicable.

Attached is the tax sale certificate on which this application is based and all other certificates of the same legal description which are in my possession.

Electronic signature on file
KEYS FUNDING LLC - 9022
PO BOX 71540
PHILADELPHIA, PA 19176-1540

04-22-2024
Application Date

Applicant's signature



Chris Jones Escambia County Property Appraiser

Real Estate Search

Tangible Property Search

Sale List

[Back](#)

← Nav. Mode Account Parcel ID →

[Printer Friendly Version](#)

General Information Parcel ID: 441S302005019002 Account: 041925109 Owners: ALLUA BRADFORD DWAYNE ALLUA CHRISTINE MARIE Mail: 2145 YARDLEY CIR PENSACOLA, FL 32526 Situs: 2145 YARDLEY CIR 32526 Use Code: SINGLE FAMILY RESID Taxing Authority: COUNTY MSTU Tax Inquiry: Open Tax Inquiry Window Tax Inquiry link courtesy of Scott Lunsford Escambia County Tax Collector						Assessments <table border="1"> <thead> <tr> <th>Year</th> <th>Land</th> <th>Imprv</th> <th>Total</th> <th>Cap Val</th> </tr> </thead> <tbody> <tr> <td>2023</td> <td>\$30,000</td> <td>\$201,137</td> <td>\$231,137</td> <td>\$213,605</td> </tr> <tr> <td>2022</td> <td>\$25,000</td> <td>\$182,384</td> <td>\$207,384</td> <td>\$207,384</td> </tr> <tr> <td>2021</td> <td>\$20,000</td> <td>\$109,003</td> <td>\$129,003</td> <td>\$129,003</td> </tr> </tbody> </table> <p style="text-align: center;">Disclaimer</p> <p style="text-align: center;">Tax Estimator</p> <p style="text-align: center;">File for Exemption(s) Online</p> <p style="text-align: center;">Report Storm Damage</p>					Year	Land	Imprv	Total	Cap Val	2023	\$30,000	\$201,137	\$231,137	\$213,605	2022	\$25,000	\$182,384	\$207,384	\$207,384	2021	\$20,000	\$109,003	\$129,003	\$129,003																												
Year	Land	Imprv	Total	Cap Val																																																						
2023	\$30,000	\$201,137	\$231,137	\$213,605																																																						
2022	\$25,000	\$182,384	\$207,384	\$207,384																																																						
2021	\$20,000	\$109,003	\$129,003	\$129,003																																																						
Sales Data <table border="1"> <thead> <tr> <th>Sale Date</th> <th>Book</th> <th>Page</th> <th>Value</th> <th>Type</th> <th>Official Records (New Window)</th> </tr> </thead> <tbody> <tr> <td>09/30/2021</td> <td>8633</td> <td>520</td> <td>\$255,000</td> <td>WD</td> <td></td> </tr> <tr> <td>03/06/2020</td> <td>8261</td> <td>691</td> <td>\$170,000</td> <td>WD</td> <td></td> </tr> <tr> <td>03/30/2012</td> <td>6838</td> <td>133</td> <td>\$65,000</td> <td>WD</td> <td></td> </tr> <tr> <td>03/2006</td> <td>5874</td> <td>1286</td> <td>\$110,000</td> <td>WD</td> <td></td> </tr> <tr> <td>03/2006</td> <td>5859</td> <td>1318</td> <td>\$100</td> <td>QC</td> <td></td> </tr> <tr> <td>12/2004</td> <td>5569</td> <td>1642</td> <td>\$100</td> <td>WD</td> <td></td> </tr> <tr> <td>07/2002</td> <td>4946</td> <td>861</td> <td>\$100</td> <td>WD</td> <td></td> </tr> </tbody> </table> Official Records Inquiry courtesy of Pam Childers Escambia County Clerk of the Circuit Court and Comptroller						Sale Date	Book	Page	Value	Type	Official Records (New Window)	09/30/2021	8633	520	\$255,000	WD		03/06/2020	8261	691	\$170,000	WD		03/30/2012	6838	133	\$65,000	WD		03/2006	5874	1286	\$110,000	WD		03/2006	5859	1318	\$100	QC		12/2004	5569	1642	\$100	WD		07/2002	4946	861	\$100	WD		2023 Certified Roll Exemptions HOMESTEAD EXEMPTION,VETERANS <hr/> Legal Description LT 19 BLK B SOMERSET S/D PB 9 P 39 OR 8633 P 520 <hr/> Extra Features METAL SHED POOL				
Sale Date	Book	Page	Value	Type	Official Records (New Window)																																																					
09/30/2021	8633	520	\$255,000	WD																																																						
03/06/2020	8261	691	\$170,000	WD																																																						
03/30/2012	6838	133	\$65,000	WD																																																						
03/2006	5874	1286	\$110,000	WD																																																						
03/2006	5859	1318	\$100	QC																																																						
12/2004	5569	1642	\$100	WD																																																						
07/2002	4946	861	\$100	WD																																																						

Parcel Information

[Launch Interactive Map](#)

Section Map Id:
44-1S-30-2



Approx. Acreage:
0.4222

Zoned:  MDR
MDR
MDR
MDR
MDR
MDR
MDR
MDR
MDR
MDR
MDR
MDR
MDR
MDR
MDR
MDR

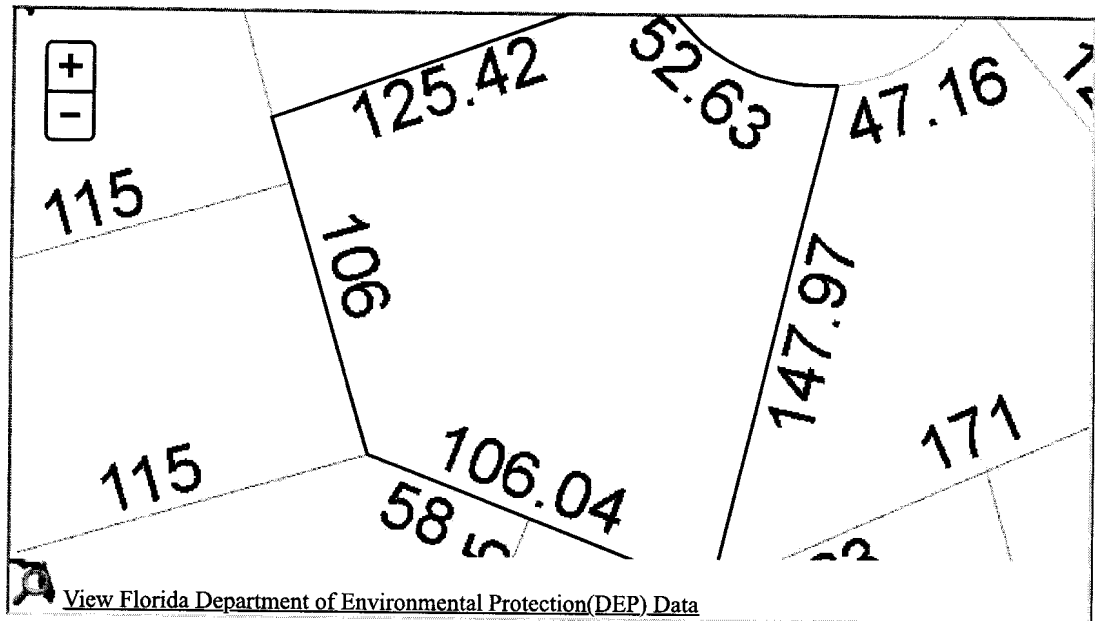

[View Florida Department of Environmental Protection\(DEP\) Data](#)

Evacuation & Flood Information
[Open Report](#)

Buildings

Address: 2145 YARDLEY CIR, Year Built: 1977, Effective Year: 2000, PA Building ID#: 68548

- Structural Elements**
- DECOR/MILLWORK-AVERAGE
 - DWELLING UNITS-1
 - EXTERIOR WALL-STONE
 - EXTERIOR WALL-SIDING-LAP.AAVG
 - FLOOR COVER-HARDWOOD/PARQET
 - FOUNDATION-SLAB ON GRADE
 - HEAT/AIR-CENTRAL H/AC
 - INTERIOR WALL-DRYWALL-PLASTER
 - NO. PLUMBING FIXTURES-8
 - NO. STORIES-1
 - ROOF COVER-DIMEN/ARCH SHNG
 - ROOF FRAMING-GABL/HIP COMBO
 - STORY HEIGHT-0
 - STRUCTURAL FRAME-WOOD FRAME

 Areas - 2180 Total SF
BASE AREA - 1556
GARAGE FIN - 504
PATIO FINISHED - 120

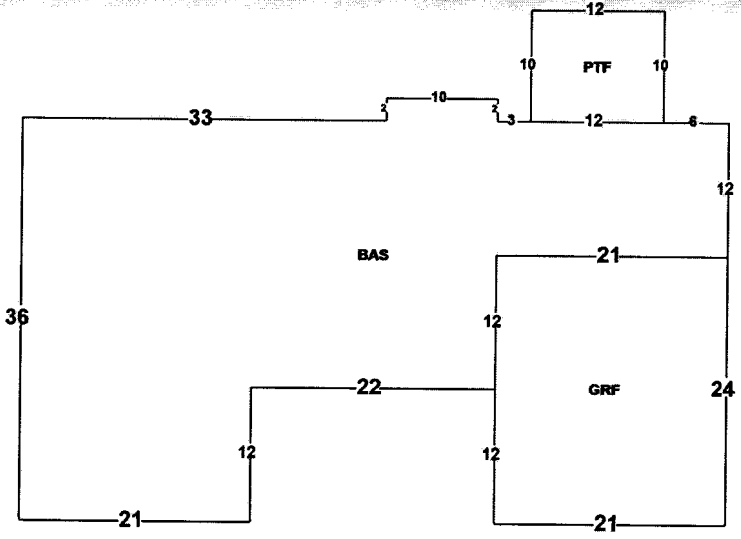

Images



3/18/2022 12:00:00 AM

The primary use of the assessment data is for the preparation of the current year tax roll. No responsibility or liability is assumed for inaccuracies or errors.

PAM CHILDERS
 CLERK OF THE CIRCUIT COURT
 ARCHIVES AND RECORDS
 CHILDSUPPORT
 CIRCUIT CIVIL
 CIRCUIT CRIMINAL
 COUNTY CIVIL
 COUNTY CRIMINAL
 DOMESTIC RELATIONS
 FAMILY LAW
 JURY ASSEMBLY
 JUVENILE
 MENTAL HEALTH
 MIS
 OPERATIONAL SERVICES
 PROBATE
 TRAFFIC



BRANCH OFFICES
ARCHIVES AND RECORDS
JUVENILE DIVISION
CENTURY

CLERK TO THE BOARD OF
 COUNTY COMMISSIONERS
 OFFICIAL RECORDS
 COUNTY TREASURY
 AUDITOR

COUNTY OF ESCAMBIA
OFFICE OF THE
CLERK OF THE CIRCUIT COURT

PAM CHILDERS, CLERK OF THE CIRCUIT COURT
Tax Certificate Redeemed From Sale
Account: 041925109 Certificate Number: 001667 of 2022

Payor: PHH MORTGAGE SERVICES ATTN: TAX DEPARTMENT 1661 WORTHINGTON RD WEST
PALM BEACH FL 33407 Date 8/29/2024

Clerk's Check #	4320178946	Clerk's Total	\$538.08 \$2,935.04
Tax Collector Check #	1	Tax Collector's Total	\$3,084.75
		Postage	\$100.00
		Researcher Copies	\$0.00
		Recording	\$10.00
		Prep Fee	\$7.00
		Total Received	\$3,739.83 \$2,952.04

PAM CHILDERS
 Clerk of the Circuit Court

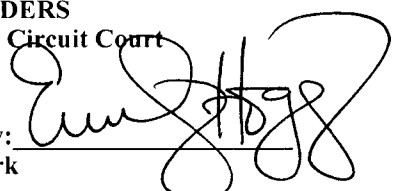
Received By: 
 Deputy Clerk

PAM CHILDERS
 CLERK OF THE CIRCUIT COURT
 ARCHIVES AND RECORDS
 CHILDSUPPORT
 CIRCUIT CIVIL
 CIRCUIT CRIMINAL
 COUNTY CIVIL
 COUNTY CRIMINAL
 DOMESTIC RELATIONS
 FAMILY LAW
 JURY ASSEMBLY
 JUVENILE
 MENTAL HEALTH
 MIS
 OPERATIONAL SERVICES
 PROBATE
 TRAFFIC

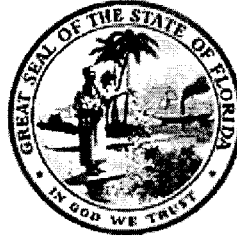

BRANCH OFFICES
ARCHIVES AND RECORDS
JUVENILE DIVISION
CENTURY

CLERK TO THE BOARD OF
 COUNTY COMMISSIONERS
 OFFICIAL RECORDS
 COUNTY TREASURY
 AUDITOR

COUNTY OF ESCAMBIA
OFFICE OF THE
CLERK OF THE CIRCUIT COURT

Case # 2022 TD 001667
Redeemed Date 8/29/2024

Name PHH MORTGAGE SERVICES ATTN: TAX DEPARTMENT 1661 WORTHINGTON RD WEST PALM BEACH FL 33407

Clerk's Total = TAXDEED	\$538.08 \$2,935.04
Due Tax Collector = TAXDEED	\$3,084.75
Postage = TD2	\$100.00
ResearcherCopies = TD6	\$0.00
Release TDA Notice (Recording) = RECORD2	\$10.00
Release TDA Notice (Prep Fee) = TD4	\$7.00

• For Office Use Only

Date	Docket	Desc	Amount Owed	Amount Due	Payee Name
------	--------	------	-------------	------------	------------

FINANCIAL SUMMARY

No Information Available - See Dockets

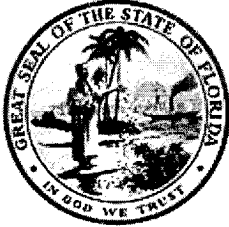

PAM CHILDERS
CLERK OF THE CIRCUIT COURT
ESCAMBIA COUNTY, FLORIDA

Tax Deed - Redemption Calculator

Account: 041925109 Certificate Number: 001667 of 2022

Redemption No Application Date Interest Rate

	Final Redemption Payment ESTIMATED	Redemption Overpayment ACTUAL
	Auction Date <input type="text" value="4/2/2025"/>	Redemption Date <input type="text" value="8/29/2024"/>
Months	12	4
Tax Collector	<input type="text" value="\$2,608.90"/>	<input type="text" value="\$2,608.90"/>
Tax Collector Interest	\$469.60	\$156.53
Tax Collector Fee	<input type="text" value="\$6.25"/>	<input type="text" value="\$6.25"/>
Total Tax Collector	\$3,084.75	<input type="text" value="\$2,771.68"/> TC
Record TDA Notice	<input type="text" value="\$17.00"/>	<input type="text" value="\$17.00"/>
Clerk Fee	<input type="text" value="\$119.00"/>	<input type="text" value="\$119.00"/>
Sheriff Fee	<input type="text" value="\$120.00"/>	<input type="text" value="\$120.00"/>
Legal Advertisement	<input type="text" value="\$200.00"/>	<input type="text" value="\$200.00"/>
App. Fee Interest	\$82.08	\$27.36
Total Clerk	\$538.08	<input type="text" value="\$483.36"/> CA
Release TDA Notice (Recording)	<input type="text" value="\$10.00"/>	<input type="text" value="\$10.00"/>
Release TDA Notice (Prep Fee)	<input type="text" value="\$7.00"/>	<input type="text" value="\$7.00"/>
Postage	<input type="text" value="\$100.00"/>	<input type="text" value="\$0.00"/>
Researcher Copies	<input type="text" value="\$0.00"/>	<input type="text" value="\$0.00"/>
Total Redemption Amount	\$3,739.83	\$3,272.04
	Repayment Overpayment Refund Amount	\$467.79
Book/Page	<input type="text" value="9147"/>	<input type="text" value="1953"/>