



CERTIFICATION OF TAX DEED APPLICATION

Sections 197.502 and 197.542, Florida Statutes

DR-513
Rule 12D-16.002 F.A.C
Effective 07/19
Page 1 of 2

0924-55

Part 1: Tax Deed Application Information

Applicant Name Applicant Address	ASSEMBLY TAX 36, LLC ASSEMBLY TAX 36 LLC FBO SEC PTY PO BOX 12225 NEWARK, NJ 07101-3411	Application date	Apr 11, 2024
Property description	BRADLEY UAL JR 12758 SW 265TH TERRACE HOMESTEAD, FL 33032 8125 CRYSTAL WELLS PL 02-5000-295 LT 19 CRYSTAL WELLS PB 13 P 19 OR 5728 P 938 OR 5956 P 483	Certificate #	2022 / 920
		Date certificate issued	06/01/2022

Part 2: Certificates Owned by Applicant and Filed with Tax Deed Application

Column 1 Certificate Number	Column 2 Date of Certificate Sale	Column 3 Face Amount of Certificate	Column 4 Interest	Column 5: Total (Column 3 + Column 4)
# 2022/920	06/01/2022	1,898.98	94.95	1,993.93
→ Part 2: Total*				1,993.93

Part 3: Other Certificates Redeemed by Applicant (Other than County)

Column 1 Certificate Number	Column 2 Date of Other Certificate Sale	Column 3 Face Amount of Other Certificate	Column 4 Tax Collector's Fee	Column 5 Interest	Total (Column 3 + Column 4 + Column 5)
# 2023/883	06/01/2023	2,104.10	6.25	105.21	2,215.56
Part 3: Total*					2,215.56

Part 4: Tax Collector Certified Amounts (Lines 1-7)

1. Cost of all certificates in applicant's possession and other certificates redeemed by applicant (*Total of Parts 2 + 3 above)	4,209.49
2. Delinquent taxes paid by the applicant	0.00
3. Current taxes paid by the applicant	2,151.35
4. Property information report fee	200.00
5. Tax deed application fee	175.00
6. Interest accrued by tax collector under s.197.542, F.S. (see Tax Collector Instructions, page 2)	0.00
7. Total Paid (Lines 1-6)	6,735.84

I certify the above information is true and the tax certificates, interest, property information report fee, and tax collector's fees have been paid, and that the property information statement is attached.

Sign here: Candice Lewis Escambia, Florida
 Signature, Tax Collector or Designee Date April 22nd, 2024

Send this certification to the Clerk of Court by 10 days after the date signed. See Instructions on Page 2

Part 5: Clerk of Court Certified Amounts (Lines 8-14)	
8. Processing tax deed fee	
9. Certified or registered mail charge	
10. Clerk of Court advertising, notice for newspaper, and electronic auction fees	
11. Recording fee for certificate of notice	
12. Sheriff's fees	
13. Interest (see Clerk of Court Instructions, page 2)	
14. Total Paid (Lines 8-13)	
15. Plus one-half of the assessed value of homestead property, if applicable under s. 197.502(6)(c), F.S.	
16. Statutory opening bid (total of Lines 7, 14, 15, and 16 if applicable)	
Sign here: _____ Date of sale <u>09/04/2024</u>	
Signature, Clerk of Court or Designee	

INSTRUCTIONS

+ 6.25

Tax Collector (complete Parts 1-4)

Part 2: Certificates Owned by Applicant and Filed with Tax Deed Application

Enter the Face Amount of Certificate in Column 3 and the Interest in Column 4 for each certificate number. Add Columns 3 and 4 and enter the amount in Column 5.

Part 3: Other Certificates Redeemed by Applicant (Other than County)

Total. Add the amounts in Columns 3, 4 and 5

Part 4: Tax Collector Certified Amounts (Lines 1-7)

Line 1, enter the total of Part 2 plus the total of Part 3 above.

Total Paid, Line 7: Add the amounts of Lines 1-6

Line 6, Interest accrued by tax collector. Calculate the 1.5 percent interest accrued from the month after the date of application through the month this form is certified to the clerk. Enter the amount to be certified to the clerk on Line 6. The interest calculated by the tax collector stops before the interest calculated by the clerk begins. See Section 197.542, F.S., and Rule 12D-13.060(3), Florida Administrative Code.

The tax collector's interest for redemption at the time of the tax deed application is a cost of redemption, which encompasses various percentages of interest on certificates and omitted or delinquent taxes under Section 197.502, F.S. This interest is calculated before the tax collector calculates the interest in Section 197.542, F.S.

Attach certified statement of names and addresses of persons who must be notified before the sale of the property. Send this form and any required attachments to the Clerk of Court within 10 days after it is signed.

Clerk of Court (complete Part 5)

Line 13: Interest is calculated at the rate of 1.5 percent per month starting from the first day of the month after the month of certification of this form through the last day of the month in which the sale will be held. Multiply the calculated rate by the total of Line 7, minus Line 6, plus Lines 8 through 12. Enter the amount on Line 13.

Line 14: Enter the total of Lines 8-13. Complete Lines 15-18, if applicable.

APPLICATION FOR TAX DEED

Section 197.502, Florida Statutes

512
R. 12/16

Application Number: 2400217

To: Tax Collector of ESCAMBIA COUNTY, Florida

I,
ASSEMBLY TAX 36, LLC
ASSEMBLY TAX 36 LLC FBO SEC PTY
PO BOX 12225
NEWARK, NJ 07101-3411,

hold the listed tax certificate and hereby surrender the same to the Tax Collector and make tax deed application thereon:

Account Number	Certificate No.	Date	Legal Description
02-5000-295	2022/920	06-01-2022	LT 19 CRYSTAL WELLS PB 13 P 19 OR 5728 P 938 OR 5956 P 483

I agree to:

- pay any current taxes, if due and
- redeem all outstanding tax certificates plus interest not in my possession, and
- pay all delinquent and omitted taxes, plus interest covering the property.
- pay all Tax Collector's fees, property information report costs, Clerk of the Court costs, charges and fees, and Sheriff's costs, if applicable.

Attached is the tax sale certificate on which this application is based and all other certificates of the same legal description which are in my possession.

Electronic signature on file
ASSEMBLY TAX 36, LLC
ASSEMBLY TAX 36 LLC FBO SEC PTY
PO BOX 12225
NEWARK, NJ 07101-3411

04-11-2024
Application Date

Applicant's signature



Chris Jones Escambia County Property Appraiser

Real Estate Search

Tangible Property Search

Sale List

[Back](#)

◀ Nav. Mode Account Parcel ID ▶

[Printer Friendly Version](#)

General Information		Assessments				
Parcel ID:	211S302900000019	Year	Land	Imprv	Total	Cap Val
Account:	025000295	2023	\$25,000	\$139,666	\$164,666	\$137,470
Owners:	BRADLEY UAL JR	2022	\$15,000	\$126,298	\$141,298	\$124,973
Mail:	12758 SW 265TH TERRACE HOMESTEAD, FL 33032	2021	\$15,000	\$99,466	\$114,466	\$113,612
Situs:	8125 CRYSTAL WELLS PL 32514	Disclaimer				
Use Code:	SINGLE FAMILY RESID	Tax Estimator				
Taxing Authority:	COUNTY MSTU	File for Exemption(s) Online				
Tax Inquiry:	Open Tax Inquiry Window	Report Storm Damage				
Tax Inquiry link courtesy of Scott Lunsford Escambia County Tax Collector						

Sales Data						2023 Certified Roll Exemptions
Sale Date	Book	Page	Value	Type	Official Records (New Window)	None
06/2006	5956	483	\$100	QC		Legal Description LT 19 CRYSTAL WELLS PB 13 P 19 OR 5728 P 938 OR 5956 P 483
09/2005	5728	938	\$100	CJ		
10/1986	2295	233	\$62,900	WD		
Official Records Inquiry courtesy of Pam Childers Escambia County Clerk of the Circuit Court and Comptroller						Extra Features METAL BUILDING

Section Map Id:
21-1S-30-1

Approx. Acreage:
0.1489

Zoned:
HDMU
HDMU
HDMU
HDMU
HDMU
HDMU
HDMU

Evacuation & Flood Information [View Florida Department of Environmental Protection\(DEP\) Data](#)

[Open Report](#)

Parcel Information [Launch Interactive Map](#)

Buildings

Address: 8125 CRYSTAL WELLS PL, Year Built: 1986, Effective Year: 1986, PA Building ID#: 54546

Structural Elements

DECOR/MILLWORK-ABOVE AVERAGE
DWELLING UNITS-1
EXTERIOR WALL-BRICK-FACE/VENEER
EXTERIOR WALL-VINYL SIDING
FLOOR COVER-CARPET
FOUNDATION-SLAB ON GRADE
HEAT/AIR-CENTRAL H/AC
INTERIOR WALL-DRYWALL-PLASTER
NO. PLUMBING FIXTURES-6
NO. STORIES-1
ROOF COVER-DIMEN/ARCH SHNG
ROOF FRAMING-GABLE-HI PITCH
STORY HEIGHT-0
STRUCTURAL FRAME-WOOD FRAME

 Areas - 1774 Total SF

BASE AREA - 1401
GARAGE FIN - 273
OPEN PORCH FIN - 100

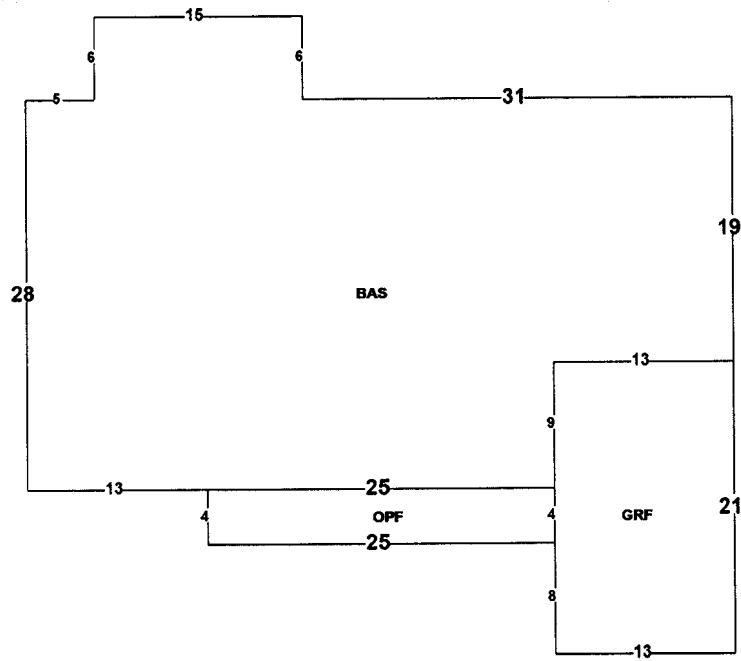

Images



4/21/2022 12:00:00 AM

The primary use of the assessment data is for the preparation of the current year tax roll. No responsibility or liability is assumed for inaccuracies or errors.

Pam Childers
CLERK OF THE CIRCUIT COURT
ESCAMBIA COUNTY FLORIDA
INST# 2024031112 4/26/2024 10:30 AM
OFF REC BK: 9137 PG: 538 Doc Type: TDN

NOTICE OF APPLICATION FOR TAX DEED

NOTICE IS HEREBY GIVEN, That **ASSEMBLY TAX 36 LLC** holder of **Tax Certificate No. 00920**, issued the **1st day of June, A.D., 2022** has filed same in my office and has made application for a tax deed to be issued thereon. Said certificate embraces the following described property in the County of Escambia, State of Florida, to wit:

LT 19 CRYSTAL WELLS PB 13 P 19 OR 5728 P 938 OR 5956 P 483

SECTION 21, TOWNSHIP 1 S, RANGE 30 W

TAX ACCOUNT NUMBER 025000295 (0924-55)

The assessment of the said property under the said certificate issued was in the name of

UAL BRADLEY JR

Unless said certificate shall be redeemed according to law, the property described therein will be sold to the highest bidder at public auction at 9:00 A.M. on the **first Wednesday** in the month of September, which is the **4th day of September 2024**.

Dated this 26th day of April 2024.

In accordance with the AMERICANS WITH DISABILITIES ACT, if you are a person with a disability who needs special accommodation in order to participate in this proceeding you are entitled to the provision of certain assistance. Please contact Emily Hogg not later than seven days prior to the proceeding at Escambia County Government Complex, 221 Palafox Place Ste 110, Pensacola FL 32502. Telephone: 850-595-3793.



PAM CHILDERS
CLERK OF THE CIRCUIT COURT
ESCAMBIA COUNTY, FLORIDA

By:
Emily Hogg
Deputy Clerk



PROPERTY INFORMATION REPORT
3050 Concho Drive, Pensacola, Florida 32507 | Phone: 850-466-3077

THE ATTACHED REPORT IS ISSUED TO:

SCOTT LUNSFORD, ESCAMBIA COUNTY TAX COLLECTOR

TAX ACCOUNT #: 02-5000-295 CERTIFICATE #: 2022-920

THIS REPORT IS NOT TITLE INSURANCE. THE LIABILITY FOR ERRORS OR OMISSIONS IN THIS REPORT IS LIMITED TO THE PERSON(S) EXPRESSLY IDENTIFIED BY NAME IN THE PROPERTY INFORMATION REPORT AS THE RECIPIENT(S) OF THE PROPERTY INFORMATION REPORT.

The attached Report prepared in accordance with the instructions given by the user named above includes a listing of the owner(s) of record of the land described herein together with current and delinquent ad valorem tax information and a listing and copies of all open or unsatisfied leases, mortgages, judgments and encumbrances recorded in the Official Record Books of Escambia County, Florida that appear to encumber the title to said land as listed on page 2 herein. It is the responsibility of the party named above to verify receipt of each document listed. If a copy of any document listed is not received, the office issuing this Report must be contacted immediately.

This Report is subject to: Current year taxes; taxes and assessments due now or in subsequent years; oil, gas, and mineral or any subsurface rights of any kind or nature; easements, restrictions and covenants of record; encroachments, overlaps, boundary line disputes, and any other matters that would be disclosed by an accurate survey and inspection of the premises.

This Report does not insure or guarantee the validity or sufficiency of any document attached, nor is it to be considered a title insurance policy, an opinion of title, a guarantee of title, or as any other form of guarantee or warranty of title.

Use of the term "Report" herein refers to the Property Information Report and the documents attached hereto.

Period Searched: May 20, 2004 to and including May 20, 2024 Abstractor: Cody Campbell

BY

Michael A. Campbell,
As President
Dated: May 26, 2024

PROPERTY INFORMATION REPORT
CONTINUATION PAGE

May 26, 2024

Tax Account #: **02-5000-295**

1. The Grantee(s) of the last deed(s) of record is/are: **UAL BRADLEY, JR.**

By Virtue of Quit Claim Deed recorded 7/25/2006 in OR 5956/483

**ABTRACTOR'S NOTE: DEED ABOVE APPEARS TO CONTAIN AN ERROR ON
ACKNOWLEDGEMENT AS TO UAL BRADLEY, JR.'S SIGNATURE**

2. The land covered by this Report is: **See Attached Exhibit "A"**
3. The following unsatisfied mortgages, liens, and judgments affecting the land covered by this Report appear of record:

NONE

4. Taxes:

Taxes for the year(s) 2021 - 2023 are delinquent.

Tax Account #: 02-5000-295

Assessed Value: \$137,470.00

Exemptions: NONE

5. We find the following HOA names in our search (if a condominium, the condo docs book and page are included for your review): **NONE**

Payment of any special liens/assessments imposed by City, County, and/or State.

Note: Escambia County and/or local municipalities may impose special liens/assessments. These liens/assessments are not discovered in a title search or shown above. These special assessments typically create a lien on real property. The entity that governs subject property must be contacted to verify payment status.

PERDIDO TITLE & ABSTRACT, INC.
PROPERTY INFORMATION REPORT
3050 Concho Drive, Pensacola, Florida 32507 | Phone 850-466-3077

Scott Lunsford
Escambia County Tax Collector
P.O. Box 1312
Pensacola, FL 32591

CERTIFICATION: TITLE SEARCH FOR TDA

TAX DEED SALE DATE: _____ **SEP 4, 2024**
TAX ACCOUNT #: _____ **02-5000-295**
CERTIFICATE #: _____ **2022-920**

In compliance with Section 197.522, Florida Statutes, the following is a list of names and addresses of those persons, firms, and/or agencies having legal interest in or claim against the above-described property. The above-referenced tax sale certificate is being submitted as proper notification of tax deed sale.

- | YES | NO | |
|--------------------------|-------------------------------------|--|
| <input type="checkbox"/> | <input checked="" type="checkbox"/> | Notify City of Pensacola, P.O. Box 12910, 32521 |
| <input type="checkbox"/> | <input checked="" type="checkbox"/> | Notify Escambia County, 190 Governmental Center, 32502 |
| <input type="checkbox"/> | <input checked="" type="checkbox"/> | Homestead for <u>2023</u> tax year. |

UAL BRADLEY, JR.
8125 CRYSTAL WELLS PL
PENSACOLA, FL 32514

UAL BRADLEY, JR.
12758 SW 265TH TERRACE
HOMESTEAD, FL 33032

Certified and delivered to Escambia County Tax Collector, this 26th day of May, 2024.

PERDIDO TITLE & ABSTRACT, INC.



BY: Michael A. Campbell, As It's President

NOTE: The above listed addresses are based upon current information available, but addresses are not guaranteed to be true or correct.

PROPERTY INFORMATION REPORT

May 26, 2024

Tax Account #:02-5000-295

**LEGAL DESCRIPTION
EXHIBIT "A"**

LT 19 CRYSTAL WELLS PB 13 P 19 OR 5728 P 938 OR 5956 P 483

SECTION 21, TOWNSHIP 1 S, RANGE 30 W

TAX ACCOUNT NUMBER 02-5000-295 (0924-55)

Prepared By
LAND OPTIONS, INC.
4955 STEUBENVILLE PIKE, SUITE 401
PITTSBURGH, PA 15205
Lee Lukaszik

QUITCLAIM DEED

STATE OF: FLORIDA

COUNTY OF: ESCAMBIA

THIS INDENTURE, made the 21st day of June in the year two thousand and six, between UAL BRADLEY, JR. AND CHERYL LYNN BRADLEY, RALPH TIMOTHY BRADLEY, ALL 1/3 INTEREST, of the County of Escambia, and State of Florida, as party of the first part, hereinafter called Grantors and UAL BRADLEY, JR., of the County of Escambia, and State of Florida, who resides at 12758 SW 265th Terrace, Homestead, FL 33032, as party of the second part, hereinafter called Grantee (the words "Grantor" and "Grantee" to include their respective heirs, successors and assigns where the context requires or permits).

WITNESSETH that: Grantor, for and in consideration of the sum of Ten Dollars (\$10.00) and other valuable considerations in hand paid at and before the sealing and delivery of these presents, the receipt whereof is hereby acknowledged, by these presents does hereby remise, convey and forever QUITCLAIM unto the said grantee, UAL BRADLEY, JR., all that tract or parcel of land lying and being in Escambia County, Florida, being more particularly described as follows:

LOT 19, CRYSTAL WELLS, A SUBDIVISION OF A PORTION OF SECTION 21, TOWNSHIP 1 SOUTH, RANGE 30 WEST, ESCAMBIA COUNTY, FLORIDA, ACCORDING TO PLAT OF SAID SUBDIVISION RECORDED IN PLAT BOOK 13 AT PAGE 19 OF THE PUBLIC RECORDS OF SAID COUNTY.

This conveyance is subject to all easements and covenants of record.

Parcel #: 211S302900000019

BEING the same property The Estate of Velma Bradley, by Deed dated 9/7/2005, and recorded 9/13/2005, in the Recorder of Deeds Office of Escambia County, Florida in Book 5728, Page 938, granted and conveyed unto Ual Bradley, Jr. and Cheryl Lynn Bradley, Ralph Timothy Bradley, All 1/3 Interest, the Grantors herein.

The purpose of this Deed is to remove Brother (Ralph Timothy Bradley) and Sister (Cheryl Lynn Bradley) from title and transfer their interest over to Ual Bradley, Jr.; therefore is exempt from any Real Estate Transfer Tax

TO HAVE AND TO HOLD the said described premises to grantee, so that neither grantors nor any person or persons claiming under grantor shall at any time, by any means or ways, have, claim or demand any right or title to said premises or appurtenances, or any rights thereof.

IN WITNESS WHEREOF, Grantors have signed and sealed this deed, the day and year first above written.

Signed, sealed and delivered in the presence of:

Witness CYNTHIA WALKER

Ralph Timothy Bradley



Witness Mike Luca

(Spouse - if any)

STATE OF VIRGINIA)
)SS.
COUNTY OF FAIRFAX)

I, ~~CYNTHIA WALKER~~ notary public in and for the state of Virginia, residing in the county and state aforesaid, do certify that Ralph Timothy Bradley and (Spouse-if any) who are personally known to me, this day appeared before me personally and did acknowledge that they did sign, seal, and deliver the foregoing deed of their own free will and accord, for the purposes therein named and expressed.

In Witness Whereof, I have hereunto set my hand and official seal, this 21st day of June, 2006.



Notary Public-State of Virginia



IN WITNESS WHEREOF, Grantors have signed and sealed this deed, the day and year first above written.

Signed, sealed and delivered in the presence of:

<u>Beatrice Alnora Mateo</u> Witness <u>BEATRICE ALNORA MATEO</u>	<u>[Signature]</u> Uai Bradley, Jr.
<u>[Signature]</u> Witness <u>ROSE M. GLEA</u>	<u>[Signature]</u> Cheryl Lynn Bradley
_____	_____ (Spouse -- if any)
_____	_____ (Spouse -- if any)

STATE OF FLORIDA)
COUNTY OF Manatee)SS.
ESCAMBIA)

I, Beatrice Alnora Mateo notary public in and for the state of Florida, residing in the county and state aforesaid, do certify that Ralph Timothy Bradley and Cheryl Lynn Bradley and (Spouse(s)-if any) who are personally known to me, this day appeared before me personally and did acknowledge that they did sign, seal, and deliver the foregoing deed of their own free will and accord, for the purposes therein named and expressed.

In Witness Whereof, I have hereunto set my hand and official seal, this 23rd day of JUNE, 2006.

Beatrice Alnora Mateo
Notary Public-State of Florida

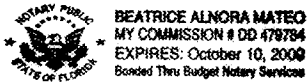

STATE OF FLORIDA
COUNTY OF ESCAMBIA

**CERTIFICATE OF NOTICE OF MAILING
NOTICE OF APPLICATION FOR TAX DEED**

CERTIFICATE # 00920 of 2022

I, PAM CHILDERS, CLERK OF THE CIRCUIT COURT OF ESCAMBIA COUNTY, FLORIDA, do hereby certify that I did on July 18, 2024, mail a copy of the foregoing Notice of Application for Tax Deed, addressed to:

UAL BRADLEY JR	UAL BRADLEY JR
12758 SW 265TH TERRACE	8125 CRYSTAL WELLS PL
HOMESTEAD, FL 33032	PENSACOLA FL 32514

WITNESS my official seal this 18th day of July 2024.



PAM CHILDERS
CLERK OF THE CIRCUIT COURT
ESCAMBIA COUNTY, FLORIDA

By:
Emily Hogg
Deputy Clerk

WARNING

THERE ARE UNPAID TAXES ON PROPERTY WHICH YOU OWN OR IN WHICH YOU HAVE A LEGAL INTEREST. THE PROPERTY WILL BE SOLD AT PUBLIC AUCTION ON September 4, 2024, UNLESS THE TAXES ARE PAID. SHOULD YOU NEED FURTHER INFORMATION CONTACT THE CLERK OF THE CIRCUIT COURT IMMEDIATELY AT THE COUNTY COURTHOUSE IN PENSACOLA, FLORIDA, OR CALL 850-595-3793.

NOTICE OF APPLICATION FOR TAX DEED

NOTICE IS HEREBY GIVEN, That ASSEMBLY TAX 36 LLC holder of Tax Certificate No. 00920, issued the 1st day of June, A.D., 2022 has filed same in my office and has made application for a tax deed to be issued thereon. Said certificate embraces the following described property in the County of Escambia, State of Florida, to wit:

LT 19 CRYSTAL WELLS PB 13 P 19 OR 5728 P 938 OR 5956 P 483

SECTION 21, TOWNSHIP 1 S, RANGE 30 W

TAX ACCOUNT NUMBER 025000295 (0924-55)

The assessment of the said property under the said certificate issued was in the name of

UAL BRADLEY JR

Unless said certificate shall be redeemed according to law, the property described therein will be sold to the highest bidder at public auction at 9:00 A.M. on the first Wednesday in the month of September, which is the 4th day of September 2024.

Dated this 22nd day of July 2024.

In accordance with the AMERICANS WITH DISABILITIES ACT, if you are a person with a disability who needs special accommodation in order to participate in this proceeding you are entitled to the provision of certain assistance. Please contact Emily Hogg not later than seven days prior to the proceeding at Escambia County Government Complex, 221 Palafox Place Ste 110, Pensacola FL 32502. Telephone: 850-595-3793.

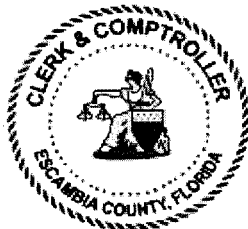

PAM CHILDERS
CLERK OF THE CIRCUIT COURT
ESCAMBIA COUNTY, FLORIDA

By:
Emily Hogg
Deputy Clerk

UAL BRADLEY JR [0924-55]
12758 SW 265TH TERRACE
HOMESTEAD, FL 33032

UAL BRADLEY JR [0924-55]
8125 CRYSTAL WELLS PL
PENSACOLA FL 32514

9171 9690 0935 0127 1857 62

9171 9690 0935 0127 1857 55

WARNING

THERE ARE UNPAID TAXES ON PROPERTY WHICH YOU OWN OR IN WHICH YOU HAVE A LEGAL INTEREST. THE PROPERTY WILL BE SOLD AT PUBLIC AUCTION ON September 4, 2024, UNLESS THE TAXES ARE PAID. SHOULD YOU NEED FURTHER INFORMATION CONTACT THE CLERK OF THE CIRCUIT COURT IMMEDIATELY AT THE COUNTY COURTHOUSE IN PENSACOLA, FLORIDA, OR CALL 850-595-3793.

NOTICE OF APPLICATION FOR TAX DEED

NOTICE IS HEREBY GIVEN, That ASSEMBLY TAX 36 LLC holder of Tax Certificate No. 00920, issued the 1st day of June, A.D., 2022 has filed same in my office and has made application for a tax deed to be issued thereon. Said certificate embraces the following described property in the County of Escambia, State of Florida, to wit:

LT 19 CRYSTAL WELLS PB 13 P 19 OR 5728 P 938 OR 5956 P 483

SECTION 21, TOWNSHIP 1 S, RANGE 30 W

TAX ACCOUNT NUMBER 025000295 (0924-55)

The assessment of the said property under the said certificate issued was in the name of

UAL BRADLEY JR

Unless said certificate shall be redeemed according to law, the property described therein will be sold to the highest bidder at public auction at 9:00 A.M. on the first Wednesday in the month of September, which is the 4th day of September 2024.

Dated this 22nd day of July 2024.

In accordance with the AMERICANS WITH DISABILITIES ACT, if you are a person with a disability who needs special accommodation in order to participate in this proceeding you are entitled to the provision of certain assistance. Please contact Emily Hogg not later than seven days prior to the proceeding at Escambia County Government Complex, 221 Palafox Place Ste 110, Pensacola FL 32502. Telephone: 850-595-3793.

Post Property:

8125 CRYSTAL WELLS PL 32514

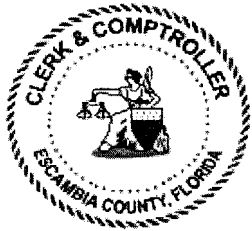

PAM CHILDERS
CLERK OF THE CIRCUIT COURT
ESCAMBIA COUNTY, FLORIDA

By:
Emily Hogg
Deputy Clerk

WARNING

THERE ARE UNPAID TAXES ON PROPERTY WHICH YOU OWN OR IN WHICH YOU HAVE A LEGAL INTEREST. THE PROPERTY WILL BE SOLD AT PUBLIC AUCTION ON September 4, 2024, UNLESS THE TAXES ARE PAID. SHOULD YOU NEED FURTHER INFORMATION CONTACT THE CLERK OF THE CIRCUIT COURT IMMEDIATELY AT THE COUNTY COURTHOUSE IN PENSACOLA, FLORIDA, OR CALL 850-595-3793.

NOTICE OF APPLICATION FOR TAX DEED

NOTICE IS HEREBY GIVEN, That **ASSEMBLY TAX 36 LLC** holder of **Tax Certificate No. 00920**, issued the **1st** day of **June, A.D., 2022** has filed same in my office and has made application for a tax deed to be issued thereon. Said certificate embraces the following described property in the County of Escambia, State of Florida, to wit:

LT 19 CRYSTAL WELLS PB 13 P 19 OR 5728 P 938 OR 5956 P 483

SECTION 21, TOWNSHIP 1 S, RANGE 30 W

TAX ACCOUNT NUMBER 025000295 (0924-55)

The assessment of the said property under the said certificate issued was in the name of

UAL BRADLEY JR

Unless said certificate shall be redeemed according to law, the property described therein will be sold to the highest bidder at public auction at 9:00 A.M. on the **first** Wednesday in the month of September, which is the **4th day of September 2024**.

Dated this 22nd day of July 2024.

In accordance with the AMERICANS WITH DISABILITIES ACT, if you are a person with a disability who needs special accommodation in order to participate in this proceeding you are entitled to the provision of certain assistance. Please contact Emily Hogg not later than seven days prior to the proceeding at Escambia County Government Complex, 221 Palafox Place Ste 110, Pensacola FL 32502. Telephone: 850-595-3793.

Personal Services:

UAL BRADLEY JR
12758 SW 265TH TERRACE
HOMESTEAD, FL 33032

PAM CHILDERS
CLERK OF THE CIRCUIT COURT
ESCAMBIA COUNTY, FLORIDA



By:
Emily Hogg
Deputy Clerk

ESCAMBIA COUNTY SHERIFF'S OFFICE
ESCAMBIA COUNTY, FLORIDA

NON-ENFORCEABLE RETURN OF SERVICE

0924-55

Document Number: ECSO24CIV025655NON

Agency Number: 24-008109

Court: TAX DEED

County: ESCAMBIA

Case Number: CERT NO 2022 00920

Attorney/Agent:

PAM CHILDERS
CLERK OF COURT
TAX DEED

Plaintiff: RE: UAL BRADLEY JR

Defendant:

Type of Process: NOTICE OF APPLICATION FOR TAX DEED

Received this Writ on 7/26/2024 at 8:44 AM and served same at 7:21 AM on 7/29/2024 in ESCAMBIA COUNTY, FLORIDA, by serving POST PROPERTY , the within named, to wit: , .

POSTED TO THE PROPERTY AS INSTRUCTED BY THE CLERKS OFFICE

CHIP W SIMMONS, SHERIFF
ESCAMBIA COUNTY, FLORIDA

By:



T. ANTHONY, CPS

Service Fee: \$40.00

Receipt No: BILL

Printed By: LCMITCHE

WARNING

THERE ARE UNPAID TAXES ON PROPERTY WHICH YOU OWN OR IN WHICH YOU HAVE A LEGAL INTEREST. THE PROPERTY WILL BE SOLD AT PUBLIC AUCTION ON September 4, 2024, UNLESS THE TAXES ARE PAID. SHOULD YOU NEED FURTHER INFORMATION CONTACT THE CLERK OF THE CIRCUIT COURT IMMEDIATELY AT THE COUNTY COURTHOUSE IN PENSACOLA, FLORIDA, OR CALL 850-595-3793.

NOTICE OF APPLICATION FOR TAX DEED

NOTICE IS HEREBY GIVEN, That ASSEMBLY TAX 36 LLC holder of Tax Certificate No. 00920, issued the 1st day of June, A.D., 2022 has filed same in my office and has made application for a tax deed to be issued thereon. Said certificate embraces the following described property in the County of Escambia, State of Florida, to wit:

LT 19 CRYSTAL WELLS PB 13 P 19 OR 5728 P 938 OR 5956 P 483

SECTION 21, TOWNSHIP 1 S, RANGE 30 W

TAX ACCOUNT NUMBER 025000295 (0924-55)

The assessment of the said property under the said certificate issued was in the name of

UAL BRADLEY JR

Unless said certificate shall be redeemed according to law, the property described therein will be sold to the highest bidder at public auction at 9:00 A.M. on the first Wednesday in the month of September, which is the 4th day of September 2024.

Dated this 22nd day of July 2024.

In accordance with the AMERICANS WITH DISABILITIES ACT, if you are a person with a disability who needs special accommodation in order to participate in this proceeding you are entitled to the provision of certain assistance. Please contact Emily Hogg not later than seven days prior to the proceeding at Escambia County Government Complex, 221 Palafox Place Ste 110, Pensacola FL 32502. Telephone: 850-595-3793.

Post Property:

8125 CRYSTAL WELLS PL 32514

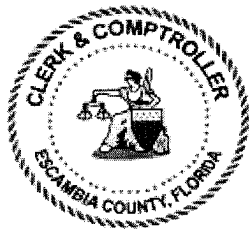

PAM CHILDERS
CLERK OF THE CIRCUIT COURT
ESCAMBIA COUNTY, FLORIDA

By:
Emily Hogg
Deputy Clerk

ESCAMBIA COUNTY, FL
2024 JUL 26 AM 9:44



Miami-Dade Police Department

Court Services Section

Stephanie V. Daniels
Director



ESCAMBIA COUNTY CLERK OF COURTS COUNTY & COMPTROLLER TAX DEEDS vs.
UAL BRADLEY JR

Case Number
025000295

RETURN OF SERVICE

TAX NOTICE

8/7/24 12:19 pm	Served - Posted Tax Notice	SERVED	UAL BRADLEY JR
-----------------	----------------------------	--------	----------------

08/01/2024 Came this day into hand of the Sheriff

08/07/2024 12:19 PM - SERVED THE TAX NOTICE UPON UAL BRADLEY JR BY POSTING A COPY AT 12758 SW 265TH TER, HOMESTEAD, FL 33032 PER FLA. STAT. 197.522(2)(A). SERVICE AFFECTED BY: PRT1 TYLER VINCENT #60407, DEPUTY SHERIFF OF MIAMI-DADE COUNTY, FL.

TYLER VINCENT, PRT1, #60407

FAM CHILDERS
CLERK & COMPTROLLER
FILED

2024 AUG 14 A 10:48

ESCAMBIA COUNTY, FL

ESCAMBIA COUNTY CLERK OF COURTS COUNTY & COMPTRO
221 PALAFOX PLACE
STE 110
PENSACOLA, FL 32502

SERVED
DATE 8/7/24
TIME 12:19 PM
BY T. Vintner
BADGE # 60401
MIAMI-DADE POLICE DEPARTMENT
OFFICE OF THE
METROPOLITAN SHERIFF
COURT SERVICES BUREAU
MIAMI-DADE COUNTY, FLORIDA

WARNING

THERE ARE UNPAID TAXES ON PROPERTY WHICH YOU OWN OR IN WHICH YOU HAVE A LEGAL INTEREST. THE PROPERTY WILL BE SOLD AT PUBLIC AUCTION ON September 4, 2024, UNLESS THE TAXES ARE PAID. SHOULD YOU NEED FURTHER INFORMATION CONTACT THE CLERK OF THE CIRCUIT COURT IMMEDIATELY AT THE COUNTY COURTHOUSE IN PENSACOLA, FLORIDA, OR CALL 850-595-3793.

NOTICE OF APPLICATION FOR TAX DEED

NOTICE IS HEREBY GIVEN, That ASSEMBLY TAX 36 LLC holder of Tax Certificate No. 00920, issued the 1st day of June, A.D., 2022 has filed same in my office and has made application for a tax deed to be issued thereon. Said certificate embraces the following described property in the County of Escambia, State of Florida, to wit:

LT 19 CRYSTAL WELLS PB 13 P 19 OR 5728 P 938 OR 5956 P 483

SECTION 21, TOWNSHIP 1 S, RANGE 30 W

TAX ACCOUNT NUMBER 025000295 (0924-55)

The assessment of the said property under the said certificate issued was in the name of

UAL BRADLEY JR

Unless said certificate shall be redeemed according to law, the property described therein will be sold to the highest bidder at public auction at 9:00 A.M. on the first Wednesday in the month of September, which is the 4th day of September 2024.

Dated this 22nd day of July 2024.

In accordance with the AMERICANS WITH DISABILITIES ACT, if you are a person with a disability who needs special accommodation in order to participate in this proceeding you are entitled to the provision of certain assistance. Please contact Emily Hogg not later than seven days prior to the proceeding at Escambia County Government Complex, 221 Palafox Place Ste 110, Pensacola FL 32502. Telephone: 850-595-3793.

Personal Services:

UAL BRADLEY JR
12758 SW 265TH TERRACE
HOMESTEAD, FL 33032

PAM CHILDERS
CLERK OF THE CIRCUIT COURT
ESCAMBIA COUNTY, FLORIDA



By:
Emily Hogg
Deputy Clerk

MUST BE SERVED ON OR
BEFORE 11/11/24
IF NOT SERVED, THEN
POST ON THE

2024 AUG 1 AM 7:40

900057434

03

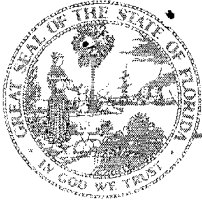

Pam Childers

Clerk of the Circuit Court and Comptroller, Escambia County

Clerk of Courts • County Comptroller • Clerk of the Board of County Commissioners • Recorder •

July 25, 2024

Miami-Dade County Sheriff
Attn: Civil Division
601 NW 1st Ct, 9th Floor
Miami, FL 33136

Dear Sheriff:

Enclosed are the Notices of Application for Tax Deeds for our September 4, 2024 Tax Deed Sale. Please serve the persons indicated on each of the notices. If you are unable to make service, please post the notice in a conspicuous place at the address provided. This service must take place no later than August 13, 2024 in order to comply with Florida Statutes.

Please find the check enclosed for payment of these services. **PLEASE CONTACT ME** at 850-595-3793 or ehogg@escambiaclerk.com if you have any questions or problems with the requested service. Thank you for your assistance and have a great day.

Sincerely,
Pam Childers
Clerk of the Circuit Court & Comptroller

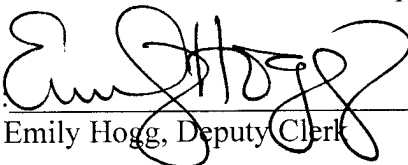
By: 
Emily Hogg, Deputy Clerk

/eh

UAL BRADLEY JR [0924-55]
12758 SW 265TH TERRACE
HOMESTEAD, FL 33032

UAL BRADLEY JR [0924-55]
8125 CRYSTAL WELLS PL
PENSACOLA FL 32514

9171 9690 0935 0127 1857 62

9171 9690 0935 0127 1857 55

Contact

WARNING

THERE ARE UNPAID TAXES ON PROPERTY WHICH YOU OWN OR IN WHICH YOU HAVE A LEGAL INTEREST. THE PROPERTY WILL BE SOLD AT PUBLIC AUCTION ON September 4, 2024, UNLESS THE TAXES ARE PAID. SHOULD YOU NEED FURTHER INFORMATION CONTACT THE CLERK OF THE CIRCUIT COURT IMMEDIATELY AT THE COUNTY COURTHOUSE IN PENSACOLA, FLORIDA, OR CALL 850-595-3793.

NOTICE OF APPLICATION FOR TAX DEED

NOTICE IS HEREBY GIVEN, That **ASSEMBLY TAX 36 LLC** holder of **Tax Certificate No. 00920**, issued the **1st** day of **June, A.D., 2022** has filed same in my office and has made application for a tax deed to be issued thereon. Said certificate embraces the following described property in the County of Escambia, State of Florida, to wit:

LT 19 CRYSTAL WELLS PB 13 P 19 OR 5728 P 938 OR 5956 P 483

SECTION 21, TOWNSHIP 1 S, RANGE 30 W

TAX ACCOUNT NUMBER 025000295 (0924-55)

The assessment of the said property under the said certificate issued was in the name of

UAL BRADLEY JR

Unless said certificate shall be redeemed according to law, the property described therein will be sold to the highest bidder at public auction at 9:00 A.M. on the **first** Wednesday in the month of September, which is the **4th day of September 2024**.

Dated this 22nd day of July 2024.

In accordance with the AMERICANS WITH DISABILITIES ACT, if you are a person with a disability who needs special accommodation in order to participate in this proceeding you are entitled to the provision of certain assistance. Please contact Emily Hogg not later than seven days prior to the proceeding at Escambia County Government Complex, 221 Palafox Place Ste 110, Pensacola FL 32502. Telephone: 850-595-3793.



**PAM CHILDERS
CLERK OF THE CIRCUIT COURT
ESCAMBIA COUNTY, FLORIDA**

By:
Emily Hogg
Deputy Clerk

CERTIFIED MAIL™

Pam Childers
Clerk of the Circuit Court & Comptroller
Official Records
221 Palafox Place, Suite 110
Pensacola, FL 32502



PENSACOLA FL 325
24 AUG 2024 PM 2:12

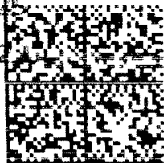

9171 9690 0935 0127 1857 55

quadiant
FIRST-CLASS MAIL
IMI
\$008.16⁰
07/26/2024 ZIP 32502
043M31219251

US POSTAGE

PAM CHILDERS
CLERK OF THE CIRCUIT COURT & COMPTROLLER
OFFICIAL RECORDS
2024 AUG 19 P 12:56
PENSACOLA COUNTY, FL

UAL BRADLEY JR [0924-55]
8125 CRYSTAL WELLS PL
PENSACOLA FL 32514

7-9-24

NIXIE 322 DE 1 0008/16/24

RETURN TO SENDER
UNCLAIMED
UNABLE TO FORWARD

BC: 32502583335 *2738-00302-26-36

UNC
32502583335
0014-00001

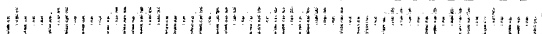



Escambia Sun Press

PUBLISHED WEEKLY SINCE 1948
(Warrington) Pensacola, Escambia County, Florida

STATE OF FLORIDA

County of Escambia

Before the undersigned authority personally appeared Michael P. Driver who is personally known to me and who on oath says that he is Publisher of The Escambia Sun Press, a weekly newspaper published at (Warrington) Pensacola in Escambia County, Florida; that the attached copy of advertisement, being a

NOTICE in the matter of TAX DEED SALE

DATE – 09-04-2024 – TAX CERTIFICATE #'S 00920

in the Court

was published in said newspaper in the issues of

AUGUST 1, 8, 15, 22, 2024

Affiant further says that the said Escambia Sun-Press is a newspaper published at (Warrington) Pensacola, in said Escambia County, Florida, and that the said newspaper has heretofore been continuously published in said Escambia County, Florida each week and has been entered as second class mail matter at the post office in Pensacola, in said Escambia and Santa Rosa Counties, Florida, for a period of one year next preceding the first publication of the attached copy of advertisement; and affiant further says that he has neither paid nor promised any person, firm or corporation any discount, rebate, commission or refund for the purpose of securing this advertisement for publication in the said newspaper.

Digitally signed by Michael P Driver
DN: c=US, o=The Escambia Sun Press LLC,
dnQualifier=A01410D0000019093B5D40A000E97D9, cn=Michael P Driver
Date: 2024.08.22 11:00:47 -05'00'

PUBLISHER

Sworn to and subscribed before me this 22ND day of AUGUST
A.D., 2024

Digitally signed by Heather Tuttle
DN: c=US, o=The Escambia Sun Press LLC,
dnQualifier=A01410C000001890CD5793600064AAE, cn=Heather Tuttle
Date: 2024.08.22 11:02:40 -05'00'

HEATHER TUTTLE
NOTARY PUBLIC



HEATHER TUTTLE
Notary Public, State of Florida
My Comm. Expires June 24, 2028
Commission No. HH 535214

NOTICE OF APPLICATION FOR TAX DEED

NOTICE IS HEREBY GIVEN, That ASSEMBLY TAX 36 LLC holder of Tax Certificate No. 00920, issued the 1st day of June, A.D., 2022 has filed same in my office and has made application for a tax deed to be issued thereon. Said certificate embraces the following described property in the County of Escambia, State of Florida, to wit:

LT 19 CRYSTAL WELLS PB 13 P 19 OR 5728 P 938 OR 5956 P 483 SECTION 21, TOWNSHIP 1 S, RANGE 30 W

TAX ACCOUNT NUMBER 025000295 (0924-55)

The assessment of the said property under the said certificate issued was in the name of UAL BRADLEY JR

Unless said certificate shall be redeemed according to law, the property described therein will be sold to the highest bidder at public auction at 9:00 A.M. on the first Wednesday in the month of September, which is the 4th day of September 2024.

Dated this 25th day of July 2024.

In accordance with the AMERICANS WITH DISABILITIES ACT, if you are a person with a disability who needs special accommodation in order to participate in this proceeding you are entitled to the provision of certain assistance. Please contact Emily Hogg not later than seven days prior to the proceeding at Escambia County Government Complex, 221 Palafox Place Ste 110, Pensacola FL 32502. Telephone: 850-595-3793.

PAM CHILDERS
CLERK OF THE CIRCUIT COURT
ESCAMBIA COUNTY, FLORIDA
(SEAL)
By: Emily Hogg
Deputy Clerk

oaw-4w-08-01-08-15-22-2024

PAM CHILDERS
 CLERK OF THE CIRCUIT COURT
 ARCHIVES AND RECORDS
 CHILDSUPPORT
 CIRCUIT CIVIL
 CIRCUIT CRIMINAL
 COUNTY CIVIL
 COUNTY CRIMINAL
 DOMESTIC RELATIONS
 FAMILY LAW
 JURY ASSEMBLY
 JUVENILE
 MENTAL HEALTH
 MIS
 OPERATIONAL SERVICES
 PROBATE
 TRAFFIC



BRANCH OFFICES
ARCHIVES AND RECORDS
JUVENILE DIVISION
CENTURY

CLERK TO THE BOARD OF
 COUNTY COMMISSIONERS
 OFFICIAL RECORDS
 COUNTY TREASURY
 AUDITOR

COUNTY OF ESCAMBIA
OFFICE OF THE
CLERK OF THE CIRCUIT COURT

PAM CHILDERS, CLERK OF THE CIRCUIT COURT
Tax Certificate Redeemed From Sale
Account: 025000295 Certificate Number: 000920 of 2022

Payor: RALPH T BRADLEY 15500 MARCH OVERLOOK DR WOODBRIDGE BA 22191 Date
9/3/2024

Clerk's Check #	1	Clerk's Total	\$400.20
Tax Collector Check #	1	Tax Collector's Total	\$7,247.28
		Postage	\$16.40
		Researcher Copies	\$0.00
		Recording	\$10.00
		Prep Fee	\$7.00
		Total Received	\$7,770.88

\$7,697.48
~~\$7,770.88~~
\$7,730.88

PAM CHILDERS
 Clerk of the Circuit Court

Received By:
 Deputy Clerk

PAM CHILDERS
 CLERK OF THE CIRCUIT COURT
 ARCHIVES AND RECORDS
 CHILDSUPPORT
 CIRCUIT CIVIL
 CIRCUIT CRIMINAL
 COUNTY CIVIL
 COUNTY CRIMINAL
 DOMESTIC RELATIONS
 FAMILY LAW
 JURY ASSEMBLY
 JUVENILE
 MENTAL HEALTH
 MIS
 OPERATIONAL SERVICES
 PROBATE
 TRAFFIC

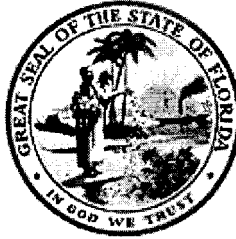

BRANCH OFFICES
ARCHIVES AND RECORDS
JUVENILE DIVISION
CENTURY

CLERK TO THE BOARD OF
 COUNTY COMMISSIONERS
 OFFICIAL RECORDS
 COUNTY TREASURY
 AUDITOR

COUNTY OF ESCAMBIA
OFFICE OF THE
CLERK OF THE CIRCUIT COURT

Case # 2022 TD 000920

Redeemed Date 9/3/2024

Name RALPH T BRADLEY 15500 MARCH OVERLOOK DR WOODBRIDGE BA 22191

Clerk's Total = TAXDEED	\$490.20
Due Tax Collector = TAXDEED	\$7,247.28
Postage = TD2	\$16.40
ResearcherCopies = TD6	\$0.00
Release TDA Notice (Recording) = RECORD2	\$10.00
Release TDA Notice (Prep Fee) = TD4	\$7.00

• For Office Use Only

Date	Docket	Desc	Amount Owed	Amount Due	Payee Name
------	--------	------	-------------	------------	------------

FINANCIAL SUMMARY

No Information Available - See Dockets

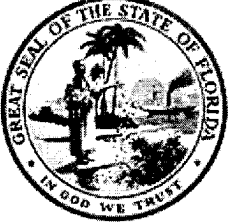

PAM CHILDERS
CLERK OF THE CIRCUIT COURT
ESCAMBIA COUNTY, FLORIDA

Tax Deed - Redemption Calculator
Account: 025000295 Certificate Number: 000920 of 2022

Redemption Yes
 Application Date
 Interest Rate

	Final Redemption Payment ESTIMATED	Redemption Overpayment ACTUAL
	Auction Date <input type="text" value="9/4/2024"/>	Redemption Date <input type="text" value="9/3/2024"/>
Months	<input type="text" value="5"/>	<input type="text" value="5"/>
Tax Collector	<input type="text" value="\$6,735.84"/>	<input type="text" value="\$6,735.84"/>
Tax Collector Interest	<input type="text" value="\$505.19"/>	<input type="text" value="\$505.19"/>
Tax Collector Fee	<input type="text" value="\$6.25"/>	<input type="text" value="\$6.25"/>
Total Tax Collector	<input type="text" value="\$7,247.28"/>	<input type="text" value="\$7,247.28"/> <i>TC</i>
Record TDA Notice	<input type="text" value="\$17.00"/>	<input type="text" value="\$17.00"/>
Clerk Fee	<input type="text" value="\$119.00"/>	<input type="text" value="\$119.00"/>
Sheriff Fee	<input type="text" value="\$120.00"/>	<input type="text" value="\$120.00"/>
Legal Advertisement	<input type="text" value="\$200.00"/>	<input type="text" value="\$200.00"/>
App. Fee Interest	<input type="text" value="\$34.20"/>	<input type="text" value="\$34.20"/>
Total Clerk	<input type="text" value="\$490.20"/>	<input type="text" value="\$490.20"/> <i>CH</i>
Release TDA Notice (Recording)	<input type="text" value="\$10.00"/>	<input type="text" value="\$10.00"/>
Release TDA Notice (Prep Fee)	<input type="text" value="\$7.00"/>	<input type="text" value="\$7.00"/>
Postage	<input type="text" value="\$16.40"/>	<input type="text" value="\$16.40"/>
Researcher Copies	<input type="text" value="\$0.00"/>	<input type="text" value="\$0.00"/>
Total Redemption Amount	<input type="text" value="\$7,770.88"/>	<input type="text" value="\$7,770.88"/>
	Repayment Overpayment Refund Amount	<input type="text" value="\$0.00"/>