



# CERTIFICATION OF TAX DEED APPLICATION

Sections 197.502 and 197.542, Florida Statutes

DR-513  
Rule 12D-16.002 F.A.C  
Effective 07/19  
Page 1 of 2

1224.65

<b>Part 1: Tax Deed Application Information</b>					
Applicant Name Applicant Address	JUAN C CAPOTE MIKON FINANCIAL SERVICES, INC. AND OCEAN BANK 780 NW 42 AVE #204 MIAMI, FL 33126	Application date	Apr 17, 2024		
Property description	MERRILL WILLIS C III PO BOX 710 PENSACOLA, FL 32591 6332 SUMMER LAKES CT 01-1602-152 LT 26 BLK A SUMMER LAKES S/D PB 14 P 27 OR 8344 P 1479	Certificate #	2022 / 141		
		Date certificate issued	06/01/2022		
<b>Part 2: Certificates Owned by Applicant and Filed with Tax Deed Application</b>					
Column 1 Certificate Number	Column 2 Date of Certificate Sale	Column 3 Face Amount of Certificate	Column 4 Interest	Column 5: Total (Column 3 + Column 4)	
# 2022/141	06/01/2022	4,360.33	218.02	4,578.35	
<b>→Part 2: Total*</b>				<b>4,578.35</b>	
<b>Part 3: Other Certificates Redeemed by Applicant (Other than County)</b>					
Column 1 Certificate Number	Column 2 Date of Other Certificate Sale	Column 3 Face Amount of Other Certificate	Column 4 Tax Collector's Fee	Column 5 Interest	Total (Column 3 + Column 4 + Column 5)
# /					
<b>Part 3: Total*</b>					<b>0.00</b>
<b>Part 4: Tax Collector Certified Amounts (Lines 1-7)</b>					
1. Cost of all certificates in applicant's possession and other certificates redeemed by applicant (*Total of Parts 2 + 3 above)				4,578.35	
2. Delinquent taxes paid by the applicant				0.00	
3. Current taxes paid by the applicant				4,867.81	
4. Property information report fee				200.00	
5. Tax deed application fee				175.00	
6. Interest accrued by tax collector under s.197.542, F.S. (see Tax Collector Instructions, page 2)				0.00	
7. <b>Total Paid (Lines 1-6)</b>				<b>9,821.16</b>	
I certify the above information is true and the tax certificates, interest, property information report fee, and tax collector's fees have been paid, and that the property information statement is attached.					
Sign here: _____	Signature, Tax Collector or Designee			Date <u>April 25th, 2024</u>	
Escambia, Florida					

Send this certification to the Clerk of Court by 10 days after the date signed. See Instructions on Page 2

+6.25

<b>Part 5: Clerk of Court Certified Amounts (Lines 8-14)</b>	
8. Processing tax deed fee	
9. Certified or registered mail charge	
10. Clerk of Court advertising, notice for newspaper, and electronic auction fees	
11. Recording fee for certificate of notice	
12. Sheriff's fees	
13. Interest (see Clerk of Court Instructions, page 2)	
14. <b>Total Paid (Lines 8-13)</b>	
15. Plus one-half of the assessed value of homestead property, if applicable under s. 197.502(6)(c), F.S.	
16. Statutory opening bid (total of Lines 7, 14, 15, and 16 if applicable)	
Sign here: _____ Date of sale <u>12/04/2024</u> Signature, Clerk of Court or Designee	

**INSTRUCTIONS**

**Tax Collector (complete Parts 1-4)**

**Part 2: Certificates Owned by Applicant and Filed with Tax Deed Application**

Enter the Face Amount of Certificate in Column 3 and the Interest in Column 4 for each certificate number. Add Columns 3 and 4 and enter the amount in Column 5.

**Part 3: Other Certificates Redeemed by Applicant (Other than County)**

**Total.** Add the amounts in Columns 3, 4 and 5

**Part 4: Tax Collector Certified Amounts (Lines 1-7)**

**Line 1,** enter the total of Part 2 plus the total of Part 3 above.

**Total Paid, Line 7:** Add the amounts of Lines 1-6

**Line 6, Interest accrued by tax collector.** Calculate the 1.5 percent interest accrued from the month after the date of application through the month this form is certified to the clerk. Enter the amount to be certified to the clerk on **Line 6**. The interest calculated by the tax collector stops before the interest calculated by the clerk begins. See Section 197.542, F.S., and Rule 12D-13.060(3), Florida Administrative Code.

The tax collector's interest for redemption at the time of the tax deed application is a cost of redemption, which encompasses various percentages of interest on certificates and omitted or delinquent taxes under Section 197.502, F.S. This interest is calculated before the tax collector calculates the interest in Section 197.542, F.S.

Attach certified statement of names and addresses of persons who must be notified before the sale of the property. Send this form and any required attachments to the Clerk of Court within 10 days after it is signed.

**Clerk of Court (complete Part 5)**

**Line 13: Interest** is calculated at the rate of 1.5 percent per month starting from the first day of the month after the month of certification of this form through the last day of the month in which the sale will be held. Multiply the calculated rate by the total of **Line 7**, minus **Line 6**, plus **Lines 8 through 12**. Enter the amount on **Line 13**.

**Line 14:** Enter the total of Lines 8-13. Complete Lines 15-18, if applicable.

# APPLICATION FOR TAX DEED

Section 197.502, Florida Statutes

512  
R. 12/16

Application Number: 2400412

To: Tax Collector of ESCAMBIA COUNTY, Florida

I,  
JUAN C CAPOTE  
MIKON FINANCIAL SERVICES, INC. AND OCEAN BANK  
780 NW 42 AVE #204  
MIAMI, FL 33126,

hold the listed tax certificate and hereby surrender the same to the Tax Collector and make tax deed application thereon:

Account Number	Certificate No.	Date	Legal Description
01-1602-152	2022/141	06-01-2022	LT 26 BLK A SUMMER LAKES S/D PB 14 P 27 OR 8344 P 1479

I agree to:

- pay any current taxes, if due and
- redeem all outstanding tax certificates plus interest not in my possession, and
- pay all delinquent and omitted taxes, plus interest covering the property.
- pay all Tax Collector's fees, property information report costs, Clerk of the Court costs, charges and fees, and Sheriff's costs, if applicable.

Attached is the tax sale certificate on which this application is based and all other certificates of the same legal description which are in my possession.

Electronic signature on file  
JUAN C CAPOTE  
MIKON FINANCIAL SERVICES, INC. AND OCEAN BANK  
780 NW 42 AVE #204  
MIAMI, FL 33126

04-17-2024  
Application Date

\_\_\_\_\_  
Applicant's signature



# Chris Jones Escambia County Property Appraiser

[Real Estate Search](#)

[Tangible Property Search](#)

[Sale List](#)

[Back](#)

← Nav. Mode  Account  Parcel ID →

[Printer Friendly Version](#)

General Information		Assessments				
<b>Parcel ID:</b>	101S291005026001	<b>Year</b>	<b>Land</b>	<b>Imprv</b>	<b>Total</b>	<b>Cap Val</b>
<b>Account:</b>	011602152	2023	\$50,000	\$241,387	\$291,387	\$268,144
<b>Owners:</b>	MERRILL WILLIS C III	2022	\$50,000	\$215,391	\$265,391	\$243,768
<b>Mail:</b>	PO BOX 710 PENSACOLA, FL 32591	2021	\$50,000	\$171,608	\$221,608	\$221,608
<b>Situs:</b>	6332 SUMMER LAKES CT 32504	<b>Disclaimer</b>				
<b>Use Code:</b>	SINGLE FAMILY RESID	<b>Tax Estimator</b>				
<b>Taxing Authority:</b>	PENSACOLA CITY LIMITS	<b>File for Exemption(s) Online</b>				
<b>Tax Inquiry:</b>	<a href="#">Open Tax Inquiry Window</a>	<b>Report Storm Damage</b>				
Tax Inquiry link courtesy of Scott Lunsford Escambia County Tax Collector						

Sales Data						2023 Certified Roll Exemptions
Sale Date	Book	Page	Value	Type	Official Records (New Window)	None
07/07/2020	8344	1479	\$100	WD		<b>Legal Description</b> LT 26 BLK A SUMMER LAKES S/D PB 14 P 27 OR 8344 P 1479
10/2004	5516	1471	\$205,000	WD		
12/2003	5313	1808	\$184,000	WD		
12/2003	5313	1805	\$184,000	WD		
08/1997	4166	1859	\$144,900	WD		
Official Records Inquiry courtesy of Pam Childers Escambia County Clerk of the Circuit Court and Comptroller						<b>Extra Features</b> FRAME BUILDING

**Section Map Id:**  
10-1S-29-1

**Approx. Acreage:**  
0.1942

**Zoned:**

- R-1A
- R-1A
- R-1A
- R-1A
- R-1A
- R-1A
- R-1A
- R-1A
- R-1A
- R-1A
- R-1A

**Evacuation**

[View Florida Department of Environmental Protection \(DEP\) Data](#)

[Launch Interactive Map](#)

**& Flood  
Information**

Open  
Report

**Buildings**

Address: 6332 SUMMER LAKES CT, Year Built: 1997, Effective Year: 1997, PA Building ID#: 37051

**Structural Elements**

DECOR/MILLWORK-ABOVE AVERAGE  
DWELLING UNITS-1  
EXTERIOR WALL-BRICK-FACE/VENEER  
FLOOR COVER-CARPET  
FOUNDATION-SLAB ON GRADE  
HEAT/AIR-CENTRAL H/AC  
INTERIOR WALL-DRYWALL-DECORAT  
NO. PLUMBING FIXTURES-8  
NO. STORIES-1  
ROOF COVER-DIMEN/ARCH SHNG  
ROOF FRAMING-GABL/HIP COMBO  
STORY HEIGHT-0  
STRUCTURAL FRAME-WOOD FRAME

 Areas - 2557 Total SF

BASE AREA - 1885  
GARAGE FIN - 462  
OPEN PORCH FIN - 66  
WOOD DECK UNF - 144

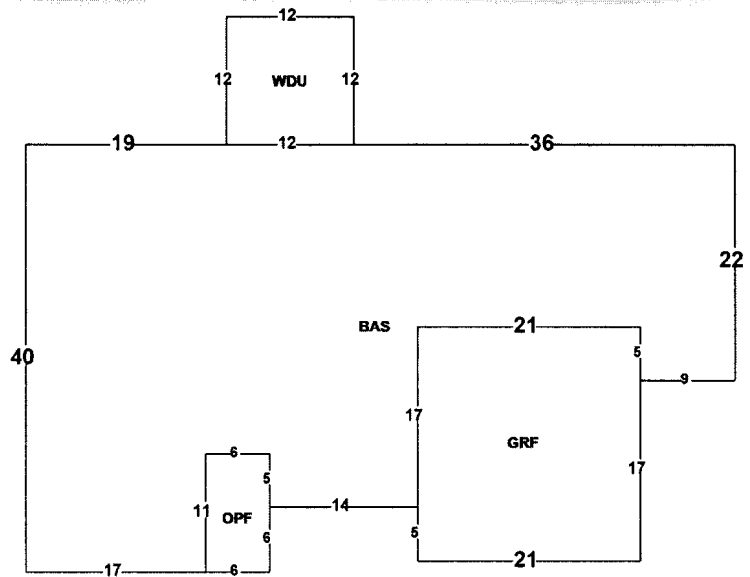

**Images**



9/2/2015 12:00:00 AM

The primary use of the assessment data is for the preparation of the current year tax roll. No responsibility or liability is assumed for inaccuracies or errors.

## NOTICE OF APPLICATION FOR TAX DEED

NOTICE IS HEREBY GIVEN, That **MIKON FINANCIAL SERVICES INC AND OCEAN BANK** holder of **Tax Certificate No. 00141**, issued the **1st** day of **June, A.D., 2022** has filed same in my office and has made application for a tax deed to be issued thereon. Said certificate embraces the following described property in the County of Escambia, State of Florida, to wit:

**LT 26 BLK A SUMMER LAKES S/D PB 14 P 27 OR 8344 P 1479**

**SECTION 10, TOWNSHIP 1 S, RANGE 29 W**

**TAX ACCOUNT NUMBER 011602152 (1224-65)**

The assessment of the said property under the said certificate issued was in the name of

**WILLIS C MERRILL III**

Unless said certificate shall be redeemed according to law, the property described therein will be sold to the highest bidder at public auction at 9:00 A.M. on the **first** Wednesday in the month of December, which is the **4th day of December 2024**.

Dated this 30th day of April 2024.

In accordance with the AMERICANS WITH DISABILITIES ACT, if you are a person with a disability who needs special accommodation in order to participate in this proceeding you are entitled to the provision of certain assistance. Please contact Emily Hogg not later than seven days prior to the proceeding at Escambia County Government Complex, 221 Palafox Place Ste 110, Pensacola FL 32502. Telephone: 850-595-3793.



PAM CHILDERS  
CLERK OF THE CIRCUIT COURT  
ESCAMBIA COUNTY, FLORIDA

By:  
Emily Hogg  
Deputy Clerk



**PROPERTY INFORMATION REPORT**  
3050 Concho Drive, Pensacola, Florida 32507 | Phone: 850-466-3077

THE ATTACHED REPORT IS ISSUED TO:

SCOTT LUNSFORD, ESCAMBIA COUNTY TAX COLLECTOR

TAX ACCOUNT #: 01-1602-152 CERTIFICATE #: 2022-141

THIS REPORT IS NOT TITLE INSURANCE. THE LIABILITY FOR ERRORS OR OMISSIONS IN THIS REPORT IS LIMITED TO THE PERSON(S) EXPRESSLY IDENTIFIED BY NAME IN THE PROPERTY INFORMATION REPORT AS THE RECIPIENT(S) OF THE PROPERTY INFORMATION REPORT.

The attached Report prepared in accordance with the instructions given by the user named above includes a listing of the owner(s) of record of the land described herein together with current and delinquent ad valorem tax information and a listing and copies of all open or unsatisfied leases, mortgages, judgments and encumbrances recorded in the Official Record Books of Escambia County, Florida that appear to encumber the title to said land as listed on page 2 herein. It is the responsibility of the party named above to verify receipt of each document listed. If a copy of any document listed is not received, the office issuing this Report must be contacted immediately.

**This Report is subject to:** Current year taxes; taxes and assessments due now or in subsequent years; oil, gas, and mineral or any subsurface rights of any kind or nature; easements, restrictions and covenants of record; encroachments, overlaps, boundary line disputes, and any other matters that would be disclosed by an accurate survey and inspection of the premises.

This Report does not insure or guarantee the validity or sufficiency of any document attached, nor is it to be considered a title insurance policy, an opinion of title, a guarantee of title, or as any other form of guarantee or warranty of title.

Use of the term "Report" herein refers to the Property Information Report and the documents attached hereto.

Period Searched: August 1, 2004 to and including August 1, 2024 Abstractor: Ben Murzin

BY

Michael A. Campbell,  
As President  
Dated: August 2, 2024

**PROPERTY INFORMATION REPORT**  
**CONTINUATION PAGE**

August 2, 2024

Tax Account #: **01-1602-152**

1. The Grantee(s) of the last deed(s) of record is/are: **WILLIS C MERRILL III**  
**By Virtue of Warranty Deed recorded 8/5/2020 in OR 8344/1479**
  
2. The land covered by this Report is: **See Attached Exhibit "A"**
  
3. The following unsatisfied mortgages, liens, and judgments affecting the land covered by this Report appear of record:
  - a. **Federal Tax Lien in favor of the Department of Treasury – Internal Revenue Service recorded 08/22/2007 in OR 6204/1133, together with Revocation of Certificate of Release recorded 09/05/2019 in OR 8158/1147**
  - b. **Federal Tax Lien in favor of the Department of Treasury – Internal Revenue Service recorded 04/15/2008 in OR 6314/351, together with Revocation of Certificate of Release recorded 09/05/2019 in OR 8158/1153**
  - c. **Federal Tax Lien in favor of the Department of Treasury – Internal Revenue Service recorded 10/08/2019 in OR 8178/749**
  - d. **Code Enforcement Lien in favor of Escambia County recorded 03/09/2023 OR 8941/997**
  
4. Taxes:  
  
**Taxes for the year(s) 2021-2023 are delinquent.**  
**Tax Account #: 01-1602-152**  
**Assessed Value: \$268,144.00**  
**Exemptions: NONE**
  
5. We find the following HOA names in our search (if a condominium, the condo docs book and page are included for your review): **SUMMER LAKES HOMEOWNERS ASSOCIATION INC.**  
**SUMMER LAKES HOMEOWNERS ASSOCIATION OF PENSACOLA, INC.**

Payment of any special liens/assessments imposed by City, County, and/or State.

Note: Escambia County and/or local municipalities may impose special liens/assessments. These liens/assessments are not discovered in a title search or shown above. These special assessments typically create a lien on real property. The entity that governs subject property must be contacted to verify payment status.



**PERDIDO TITLE & ABSTRACT, INC.**  
**PROPERTY INFORMATION REPORT**  
3050 Concho Drive, Pensacola, Florida 32507 | Phone 850-466-3077

**Scott Lunsford**  
**Escambia County Tax Collector**  
P.O. Box 1312  
Pensacola, FL 32591

**CERTIFICATION: TITLE SEARCH FOR TDA**

**TAX DEED SALE DATE:** \_\_\_\_\_ **DEC 4, 2024**  
**TAX ACCOUNT #:** \_\_\_\_\_ **01-1602-152**  
**CERTIFICATE #:** \_\_\_\_\_ **2022-141**

In compliance with Section 197.522, Florida Statutes, the following is a list of names and addresses of those persons, firms, and/or agencies having legal interest in or claim against the above-described property. The above-referenced tax sale certificate is being submitted as proper notification of tax deed sale.

YES	NO	
<input type="checkbox"/>	<input checked="" type="checkbox"/>	Notify City of Pensacola, P.O. Box 12910, 32521
<input type="checkbox"/>	<input checked="" type="checkbox"/>	Notify Escambia County, 190 Governmental Center, 32502
<input type="checkbox"/>	<input checked="" type="checkbox"/>	Homestead for <u>2023</u> tax year.

**WILLIS C MERRILL III**  
**WCM INVESTMENTS LLC**  
**PO BOX 710**  
**PENSACOLA, FL 32591**

**WILLIS C MERRILL III**  
**WCM INVESTMENTS LLC**  
**6332 SUMMER LAKES CT**  
**PENSACOLA, FL 32504**

**ESCAMBIA COUNTY**  
**CODE ENFORCEMENT**  
**3363 W PARK PL**  
**PENSACOLA, FL 32505**

**DEPARTMENT OF TREASURY**  
**INTERNAL REVENUE SERVICE**  
**400 W BAY ST STE 35045**  
**JACKSONVILLE FL 32202-4437**

**Certified and delivered to Escambia County Tax Collector, this 15<sup>th</sup> day of August, 2024.**

**PERDIDO TITLE & ABSTRACT, INC.**



BY: Michael A. Campbell, As It's President

NOTE: The above listed addresses are based upon current information available, but addresses are not guaranteed to be true or correct.

**PROPERTY INFORMATION REPORT**

**August 2, 2024**

**Tax Account #:01-1602-152**

**LEGAL DESCRIPTION  
EXHIBIT "A"**

**LT 26 BLK A SUMMER LAKES S/D PB 14 P 27 OR 8344 P 1479**

**SECTION 10, TOWNSHIP 1 S, RANGE 29 W**

**TAX ACCOUNT NUMBER 01-1602-152(1224-65)**

**Recorded in Public Records 8/5/2020 12:18 PM OR Book 8344 Page 1479,  
Instrument #2020063883, Pam Childers Clerk of the Circuit Court Escambia  
County, FL Recording \$18.50 Deed Stamps \$0.70**

This instrument was prepared by:  
Matthew L. Paolillo, Esq.  
Menden Freiman, LLP  
5565 Glenridge Connector NE  
Suite 850  
Atlanta, GA 30342  
(770) 379-1450

**WARRANTY DEED**

*(THIS INSTRUMENT PREPARED WITHOUT BENEFIT OF TITLE EXAMINATION)*

**THIS INDENTURE** is made this 7<sup>th</sup> day of July, 2020, between **WCM INVESTMENTS, LLC**, a Florida limited liability company, whose address is P.O. Box 710, Pensacola, FL 32591, ("Grantor"), and **WILLIS C. MERRILL, III**, a single man, whose address is P.O. Box 710, Pensacola, FL 32591, ("Grantee");

**WITNESSETH** that Grantor, for and in consideration of the sum of **TEN AND NO/100 (\$10.00) DOLLARS** and other good and valuable considerations to Grantor in hand paid by Grantee, the receipt whereof is hereby acknowledged, has granted, bargained and sold to Grantee, and Grantee's heirs and assigns forever, the following described land, situate, lying and being in Escambia County, Florida, to-wit:

**Lot 26, Block A of SUMMER LAKES, according to the Plat thereof as recorded in Plat Book 14, Page(s) 27, of the Public Records of Escambia County, Florida.**

**Parcel Identification No.: 10-1S-29-1005-026-001**

**Subject to all reservations, covenants, conditions, restrictions and easements of record and to all applicable zoning ordinances and/or restrictions imposed by governmental authorities, if any.**

**Together with all tenements, hereditaments and appurtenances thereto belonging or in any way appertaining. Grantor does hereby fully warrant the title to said land, and will defend the same against lawful claims of all persons whomsoever.**

**"Grantor" and "Grantee" are used for singular or plural, as context requires.**

IN WITNESS WHEREOF, Grantor has hereunto set their hand and seal the day and year first above written.

Signed, sealed, and delivered  
in our presence:

WCM INVESTMENTS, LLC

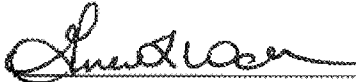
  
Witness Signature

By:   
Willis C. Merrill, III, Manager

Printed Name: Gina L. Walker

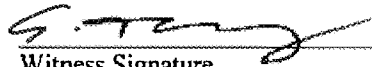
  
Witness Signature

Printed Name: Gail TULLY

STATE OF FLORIDA

COUNTY OF Escambia

THE FOREGOING INSTRUMENT was acknowledged before me this 7th day of July, 2020, by WILLIS C. MERRILL, III who is personally known to me or who has produced a Florida driver's license as identification and who did take an oath.



(NOTARY SEAL)

NOTARY PUBLIC:



Printed Name: Gail Alexandria TULLY

<b>Form 668 (Y)(c)</b> (Rev. February 2004)	3866 Department of the Treasury - Internal Revenue Service <b>\$ 10.00 DUE Notice of Federal Tax Lien</b>
--	---

Area: SMALL BUSINESS/SELF EMPLOYED AREA #3 Lien Unit Phone: (800) 913-6050	Serial Number 383363907	For Optional Use by Recording Office
--	----------------------------	--------------------------------------

**As provided by section 6321, 6322, and 6323 of the Internal Revenue Code, we are giving a notice that taxes (including interest and penalties) have been assessed against the following-named taxpayer. We have made a demand for payment of this liability, but it remains unpaid. Therefore, there is a lien in favor of the United States on all property and rights to property belonging to this taxpayer for the amount of these taxes, and additional penalties, interest, and costs that may accrue.**

Name of Taxpayer WILLIS C III MERRILL

Residence P O BOX 710  
 PENSACOLA, FL 32591

**IMPORTANT RELEASE INFORMATION:** For each assessment listed below, unless notice of the lien is refiled by the date given in column (e), this notice shall, on the day following such date, operate as a certificate of release as defined in IRC 6325(a).

Kind of Tax (a)	Tax Period Ending (b)	Identifying Number (c)	Date of Assessment (d)	Last Day for Refiling (e)	Unpaid Balance of Assessment (f)
1040	12/31/2005	XXX- [REDACTED]	11/27/2006	12/27/2016	1426532.73

Place of Filing CLERK OF CIRCUIT COURT ESCAMBIA COUNTY PENSACOLA, FL 32595	Total	\$ 1426532.73
---	-------	---------------

This notice was prepared and signed at JACKSONVILLE, FL, on this,  
 the 08th day of August, 2007.

Signature <i>R. A. Mitchell</i> for C. NICHOLS	Title REVENUE OFFICER (850) 430-1110 x1100	23-09-2414
---	--	------------

Form **12474(A)** (Rev. 10-00) --\*-- 1801 Department of the Treasury - Internal Revenue Service  
**Revocation of Certificate of Release of Federal Tax Lien**

Area: SMALL BUSINESS/SELF EMPLOYED AREA #3 Lien Unit Phone (800) 913-6050	Serial Number 383363907	For Use by Recording Office
---	----------------------------	-----------------------------

**I certify that we mistakenly allowed a Notice of Federal Tax Lien filed against the taxpayer listed below to operate as a Certificate of Release. I declare that the automatic release of the Notice of Federal Tax Lien is revoked and that the lien is reinstated as provided under Internal Revenue Code Section 6325(f)(2).**

Name of Taxpayer **WILLIS C III MERRILL**

Residence **P O BOX 710  
PENSACOLA, FL 32591**

COURT RECORDING INFORMATION:  
 Liber Page UCC No. Serial No.  
 6204 1133 n/a 2007080641

Kind of Tax (a)	Tax Period Ending (b)	Identifying Number (c)	Date of Assessment (d)	Last Day for Refiling (e)	Unpaid Balance of Assessment (f)
1040	12/31/2005	XXX-XX-██████	11/27/2006	12/27/2016	1426532.73
*****					

Place of Filing CLERK OF CIRCUIT COURT ESCAMBIA COUNTY PENSACOLA, FL 32595	Total	\$ 1426532.73
---	-------	---------------

This notice was prepared and signed at BALTIMORE, MD, on this,  
 the 04th day of September, 2019.

Signature 	Title Operations Manager, Centralized Lien Operation
--	--

**(NOTE: Certificate of officer authorized by law to take acknowledgments is not essential to the validity of Revocation of Certificate of Release of Federal Tax Lien Rev. Rul. 71-466, 1971 - 2 C.B. 409)**

**Reason for Revoking the Certificate of Release of Federal Tax Lien  
and Reinstating the Notice of Federal Tax Lien**

- Federal Tax Lien released in error.
- Failure to comply with collateral agreement  
in connection with a compromise.
- Liability was not discharged through  
litigation.
- Notice of Federal Tax Lien was not refiled  
timely.

<b>Form 668 (Y)(c)</b> (Rev. February 2004)	5219 Department of the Treasury - Internal Revenue Service <h3 style="text-align: center;">Notice of Federal Tax Lien</h3>
--	--

Area: SMALL BUSINESS/SELF EMPLOYED AREA #3 Lien Unit Phone: (800) 913-6050	Serial Number 435926108	For Optional Use by Recording Office
--	----------------------------	--------------------------------------

**As provided by section 6321, 6322, and 6323 of the Internal Revenue Code, we are giving a notice that taxes (including interest and penalties) have been assessed against the following-named taxpayer. We have made a demand for payment of this liability, but it remains unpaid. Therefore, there is a lien in favor of the United States on all property and rights to property belonging to this taxpayer for the amount of these taxes, and additional penalties, interest, and costs that may accrue.**

Name of Taxpayer WILLIS C III MERRILL

Residence P O BOX 710  
 PENSACOLA, FL 32591

**IMPORTANT RELEASE INFORMATION:** For each assessment listed below, unless notice of the lien is refiled by the date given in column (e), this notice shall, on the day following such date, operate as a certificate of release as defined in IRC 6325(a).

Kind of Tax (a)	Tax Period Ending (b)	Identifying Number (c)	Date of Assessment (d)	Last Day for Refiling (e)	Unpaid Balance of Assessment (f)
1040	12/31/2006	XXX- [REDACTED]	12/03/2007	01/02/2018	1598946.61

Place of Filing CLERK OF CIRCUIT COURT ESCAMBIA COUNTY PENSACOLA, FL 32595	Total \$ 1598946.61
---	---------------------

This notice was prepared and signed at BALTIMORE, MD, on this,  
 the 07th day of April, 2008.

Signature <i>R. A. Mitchell</i> for CATHERINE SANDS	Title REVENUE OFFICER (850) 430-1111 x1110	23-09-2412
--	--	------------



Form **12474(A)** (Rev. 10-00) --\*-- 1801 Department of the Treasury - Internal Revenue Service  
**Revocation of Certificate of Release of Federal Tax Lien**

Area: SMALL BUSINESS/SELF EMPLOYED AREA #3 Lien Unit Phone (800) 913-6050	Serial Number 435926108	For Use by Recording Office
---	----------------------------	-----------------------------

**I certify that we mistakenly allowed a Notice of Federal Tax Lien filed against the taxpayer listed below to operate as a Certificate of Release. I declare that the automatic release of the Notice of Federal Tax Lien is revoked and that the lien is reinstated as provided under Internal Revenue Code Section 6325(f)(2).**

Name of Taxpayer **WILLIS C III MERRILL**

Residence **P O BOX 710  
PENSACOLA, FL 32591**

COURT RECORDING INFORMATION:  
 Liber Page UCC No. Serial No.  
 6314 351 n/a 2008028539

Kind of Tax (a)	Tax Period Ending (b)	Identifying Number (c)	Date of Assessment: (d)	Last Day for Refiling (e)	Unpaid Balance of Assessment (f)
1040	12/31/2006	XXX-XX-████	12/03/2007	01/02/2018	1598946.61
*****					

Place of Filing <b>CLERK OF CIRCUIT COURT ESCAMBIA COUNTY PENSACOLA, FL 32595</b>	Total	\$ 1598946.61
--	-------	---------------

This notice was prepared and signed at BALTIMORE, MD, on this,  
 the 04th day of September, 2019.

Signature 	Title Operations Manager, Centralized Lien Operation
--	--

**Reason for Revoking the Certificate of Release of Federal Tax Lien  
and Reinstating the Notice of Federal Tax Lien**

- Federal Tax Lien released in error.
- Failure to comply with collateral agreement  
in connection with a compromise.
- Liability was not discharged through  
litigation.
- Notice of Federal Tax Lien was not refiled  
timely.

<b>Form 668 (Y)(c)</b> (Rev. February 2004)	18331 Department of the Treasury - Internal Revenue Service <h3 style="margin: 0;">Notice of Federal Tax Lien</h3>
--	--

Area: SMALL BUSINESS/SELF EMPLOYED AREA #3 Lien Unit Phone: (800) 913-6050	Serial Number 383791019	For Optional Use by Recording Office
--	----------------------------	--------------------------------------

**As provided by section 6321, 6322, and 6323 of the Internal Revenue Code, we are giving a notice that taxes (including interest and penalties) have been assessed against the following-named taxpayer. We have made a demand for payment of this liability, but it remains unpaid. Therefore, there is a lien in favor of the United States on all property and rights to property belonging to this taxpayer for the amount of these taxes, and additional penalties, interest, and costs that may accrue.**

Name of Taxpayer WILLIS C III MERRILL

Residence PO BOX 710  
 PENSACOLA, FL 32591-0710

**IMPORTANT RELEASE INFORMATION:** For each assessment listed below, unless notice of the lien is refiled by the date given in column (e), this notice shall, on the day following such date, operate as a certificate of release as defined in IRC 6325(a).

Kind of Tax (a)	Tax Period Ending (b)	Identifying Number (c)	Date of Assessment (d)	Last Day for Refiling (e)	Unpaid Balance of Assessment (f)
1040	12/31/2005	XXX-XX- <span style="background-color: black; color: black;">XXXXXXXXXX</span>	11/27/2006	12/27/2026	708848.08
1040	12/31/2006	XXX-XX- <span style="background-color: black; color: black;">XXXXXXXXXX</span>	12/03/2007	01/02/2028	1570791.46

Place of Filing CLERK OF CIRCUIT COURT ESCAMBIA COUNTY PENSACOLA, FL 32595	Total	\$ 2279639.54
---	-------	---------------

This notice was prepared and signed at BALTIMORE, MD, on this,  
 the 26th day of September, 2019.

Signature for JUDY ARPINO	Title REVENUE OFFICER (813) 302-5554 23-08-3709
------------------------------	--

(NOTE: Certificate of officer authorized by law to take acknowledgment is not essential to the validity of Notice of Federal Tax lien  
 Rev. Rul. 71-466, 1971 - 2 C.B. 409)

THE OFFICE OF ENVIRONMENTAL ENFORCEMENT  
SPECIAL MAGISTRATE  
IN AND FOR THE  
COUNTY OF ESCAMBIA, STATE OF FLORIDA

PETITIONER  
ESCAMBIA COUNTY FLORIDA,

CASE NO: CE22104500N  
LOCATION: 62 MARSHALL LN  
PR#: 471S301101007012

VS.

MERRILL DICKERSON  
INVESTMENTS 40% INT,  
1901 SEVILLE DR  
PENSACOLA, FL 32503

DICKERSON FAMILY  
CORPORATION 30 % INT,  
1901 SEVILLE DR  
PENSACOLA, FL 32503

MERRILL JANE H & MERRILL  
WILLIS C III & MERRILL  
BURNLEY H & MERRILL J  
COLLIER, TRUSTEES FOR  
MERRILL JANE H REVOCABLE  
TRUST 10% INT  
1901 SEVILLE DR  
PENSACOLA, FL 32503

MERRILL JANE H TRUSTEE  
FOR MERRILL WILLIS C JR  
RESIDUARY TRUST UNDER L  
W & T 20% INT,  
1901 SEVILLE DR  
PENSACOLA, FL 32503

RESPONDENT(S)

ORDER

This CAUSE having come before the Office of Environmental Enforcement  
Special Magistrate on the Petition of the Environmental Enforcement Officer for alleged  
violation of the ordinances of the County of Escambia, State of Florida, and the Special  
Magistrate having considered the evidence before him in the form of testimony by the  
Enforcement Officer and the Respondent(s) or representative thereof, None,  
as well as evidence submitted, and after consideration of the appropriate sections of  
the Escambia County Code of Ordinances, the Special Magistrate finds that a violation  
of the following Code of Ordinances has occurred and continues:

**LDC. Ch. 4. Art. 7. Sec. 4-7.9 Outdoor Storage**

**LDC. Ch. 4. Art. 7. Sec. 4-7.13 Temporary Uses and Structures (b) Specific Use and  
Structures (8) Temporary Shelters**

Unique Code : BAA-CACABFBCCDAFED-BCADD-CACDABIDJD-BIFEFB-F Page 1 of 4



**Sec. 42-196(a) Nuisance - (A) Nuisance**

**Sec. 42-196(b) Nuisance - (B) Trash and Debris**

**Sec. 42-196(c) Nuisance - (C) Inoperable Vehicle**

THEREFORE, the Special Magistrate, being otherwise fully apprised, finds as follows:

It is hereby **ORDERED** that the **RESPONDENT(S)** shall have until **4/21/2023** to correct the violation(s) and to bring the violation into compliance.

Corrective action shall include:

**Complete removal of all contributing nuisance conditions; trash, rubbish, overgrowth and legally dispose of. maintain clean conditions to avoid a repeat violation.**

**Remove vehicle(s). Repair vehicle(s) or store in rear yard behind 6' opaque fencing.**

**Remove vehicle(s). Repair vehicle(s) or store in rear yard behind 6' opaque fencing.**

**Remove all outdoor storage from the property. Store indoor items in a garage, shed or dwelling.**

**Remove all temporary structures**

If Respondent(s) fail to fully correct the violation(s) within the time required, Respondent(s) will be assessed a fine of **\$30.00** per day, commencing **4/22/2023**.

This fine shall continue until the violation(s) is/are abated and the violation(s) brought into compliance, or until as otherwise provided by law. **RESPONDENT IS REQUIRED**, immediately upon full correction of the violation(s), to contact the Escambia County Office of Environmental Enforcement in writing to request that the office immediately inspect the property to make an official determination of whether the violation(s) has/have been abated and brought into compliance. If the violation(s) is/are not abated within the specified time period, Escambia County may elect to undertake any

necessary measures to abate the violation(s). These measures could include, but are not limited to, **DEMOLISHING NON-COMPLIANT STRUCTURES, LEGALLY DISPOSING OF ALL CONTRIBUTING CONDITIONS, AND TOWING OF DESCRIBED VEHICLE(S)**.

To ensure the safety of Escambia County staff and RESPONDENT(S), Escambia County may request law enforcement supervisory assistance during any abatement procedure.

The reasonable cost of such abatement will be assessed against **RESPONDENT(S)** and shall constitute a lien on the property. Pursuant to Escambia County Resolution R2017-132, costs in the amount of **\$250.00** are awarded in favor of Escambia County as the prevailing party against **RESPONDENT(S)**.

This fine shall be forwarded to the Board of County Commissioners of Escambia County. Under the authority of Sec. 162.09, Fla. Stat., as amended, and Sec. 30-35 of the Escambia County Code of Ordinances, as amended, the Board of County Commissioners will certify to the Special Magistrate all costs imposed pursuant to this order. All fees, fines, and costs owing hereunder shall constitute a lien upon **ALL REAL AND PERSONAL PROPERTY OWNED BY RESPONDENT(S)** including property involved herein, which lien can be enforced by foreclosure and as provided by law.

**RESPONDENT(S)** have the right to appeal the order(s) of the Special Magistrate to the Circuit Court of Escambia County. If RESPONDENT(S) wish(es) to appeal, RESPONDENT(S) must provide notice of such appeal in writing to both the Environmental Enforcement Division at 3363 West Park Place, Pensacola, Florida 32505, and the Escambia County Circuit Court, M.C. Blanchard Judicial Building, 190 W. Government St, Pensacola, Florida, 32502, no later than **30 days** from the date of this order. Failure to timely file a Written Notice of Appeal will constitute a waiver of the right to appeal this order.

Jurisdiction is hereby retained to enter such further orders as may be appropriate and necessary.

**DONE AND ORDERED** in Escambia County, Florida on this 7th day of March, 2023.

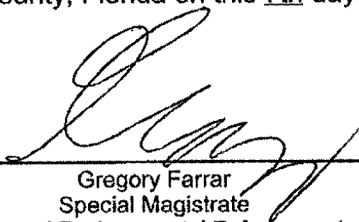

---

Gregory Farrar  
Special Magistrate  
Office of Environmental Enforcement

Unique Code : BAA-CACABFBCCDAFED-BCADD-CACDABIDJD-BIFEFB-F Page 4 of 4

**PAM CHILDERS**  
 CLERK OF THE CIRCUIT COURT  
 ARCHIVES AND RECORDS  
 CHILDSUPPORT  
 CIRCUIT CIVIL  
 CIRCUIT CRIMINAL  
 COUNTY CIVIL  
 COUNTY CRIMINAL  
 DOMESTIC RELATIONS  
 FAMILY LAW  
 JURY ASSEMBLY  
 JUVENILE  
 MENTAL HEALTH  
 MIS  
 OPERATIONAL SERVICES  
 PROBATE  
 TRAFFIC

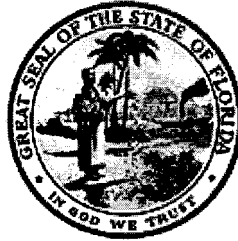

**COUNTY OF ESCAMBIA  
 OFFICE OF THE  
 CLERK OF THE CIRCUIT COURT**

**BRANCH OFFICES  
 ARCHIVES AND RECORDS  
 JUVENILE DIVISION  
 CENTURY**

CLERK TO THE BOARD OF  
 COUNTY COMMISSIONERS  
 OFFICIAL RECORDS  
 COUNTY TREASURY  
 AUDITOR

**PAM CHILDERS, CLERK OF THE CIRCUIT COURT  
 Tax Certificate Redeemed From Sale  
 Account: 011602152 Certificate Number: 000141 of 2022**

**Payor: WILLIS C MERRILL III PO BOX 710 PENSACOLA, FL 32591      Date 10/23/2024**

Clerk's Check #	1	Clerk's Total	\$510.72
Tax Collector Check #	1	Tax Collector's Total	\$11,005.95
		Postage	\$57.40
		Researcher Copies	\$0.00
		Recording	\$10.00
		Prep Fee	\$7.00
		Total Received	\$11,591.07

**PAM CHILDERS  
 Clerk of the Circuit Court**

*Redeemed*  
*\$10,905.32*

Received By:  
 Deputy Clerk

Escambia County Government Complex • 221 Palafox Place Ste 110 • PENSACOLA, FLORIDA 32502  
 (850) 595-3793 • FAX (850) 595-4827 • <http://www.clerk.co.escambia.fl.us>

*\$11,287.01*  
*w/ fee*