

APPLICATION FOR TAX DEED

Section 197.502, Florida Statutes

512
R. 12/16

Application Number: 2300326

To: Tax Collector of ESCAMBIA COUNTY, Florida

I,
JUAN C CAPOTE
MIKON FINANCIAL SERVICES, INC. AND OCEAN BANK
780 NW 42 AVE #300
MIAMI, FL 33126,

hold the listed tax certificate and hereby surrender the same to the Tax Collector and make tax deed application thereon:

Account Number	Certificate No.	Date	Legal Description
07-4448-050	2021/3154	06-01-2021	BEG AT INTER OF W LI OF 1ST ST AND N LI OF THIRD AVE NLY 360 FT FOR POB W 60 FT N TO BAYOU ELY ALG BAYOU TO W LI OF 1ST ST SLY ALG 1ST ST 230 FT TO POB LT 1 BLK 17 OF AN UNRECORDED PLAT OR 6314 P 867 CASE # 2006 CP 2295 CA 160

I agree to:

- pay any current taxes, if due and
- redeem all outstanding tax certificates plus interest not in my possession, and
- pay all delinquent and omitted taxes, plus interest covering the property.
- pay all Tax Collector's fees, property information report costs, Clerk of the Court costs, charges and fees, and Sheriff's costs, if applicable.

Attached is the tax sale certificate on which this application is based and all other certificates of the same legal description which are in my possession.

Electronic signature on file
JUAN C CAPOTE
MIKON FINANCIAL SERVICES, INC. AND OCEAN BANK
780 NW 42 AVE #300
MIAMI, FL 33126

04-26-2023
Application Date

Applicant's signature

Part 5: Clerk of Court Certified Amounts (Lines 8-14)	
8. Processing tax deed fee	
9. Certified or registered mail charge	
10. Clerk of Court advertising, notice for newspaper, and electronic auction fees	
11. Recording fee for certificate of notice	
12. Sheriff's fees	
13. Interest (see Clerk of Court Instructions, page 2)	
14. Total Paid (Lines 8-13)	
15. Plus one-half of the assessed value of homestead property, if applicable under s. 197.502(6)(c), F.S.	61,280.50
16. Statutory opening bid (total of Lines 7, 14, 15, and 16 if applicable)	
Sign here: _____ Date of sale <u>12/06/2023</u>	
Signature, Clerk of Court or Designee	

INSTRUCTIONS

Tax Collector (complete Parts 1-4)

Part 2: Certificates Owned by Applicant and Filed with Tax Deed Application

Enter the Face Amount of Certificate in Column 3 and the Interest in Column 4 for each certificate number. Add Columns 3 and 4 and enter the amount in Column 5.

Part 3: Other Certificates Redeemed by Applicant (Other than County)

Total. Add the amounts in Columns 3, 4 and 5

Part 4: Tax Collector Certified Amounts (Lines 1-7)

Line 1, enter the total of Part 2 plus the total of Part 3 above.

Total Paid, Line 7: Add the amounts of Lines 1-6

Line 6, Interest accrued by tax collector. Calculate the 1.5 percent interest accrued from the month after the date of application through the month this form is certified to the clerk. Enter the amount to be certified to the clerk on Line 6. The interest calculated by the tax collector stops before the interest calculated by the clerk begins. See Section 197.542, F.S., and Rule 12D-13.060(3), Florida Administrative Code.

The tax collector's interest for redemption at the time of the tax deed application is a cost of redemption, which encompasses various percentages of interest on certificates and omitted or delinquent taxes under Section 197.502, F.S. This interest is calculated before the tax collector calculates the interest in Section 197.542, F.S.

Attach certified statement of names and addresses of persons who must be notified before the sale of the property. Send this form and any required attachments to the Clerk of Court within 10 days after it is signed.

Clerk of Court (complete Part 5)

Line 13: Interest is calculated at the rate of 1.5 percent per month starting from the first day of the month after the month of certification of this form through the last day of the month in which the sale will be held. Multiply the calculated rate by the total of Line 7, minus Line 6, plus Lines 8 through 12. Enter the amount on Line 13.

Line 14: Enter the total of Lines 8-13. Complete Lines 15-18, if applicable.

BEG AT INTER OF W LI OF 1ST ST AND N LI OF THIRD AVE NLY 360 FT FOR POB W 60 FT N TO BAYOU ELY ALG BAYOU TO W LI OF 1ST ST SLY ALG 1ST ST 230 FT TO POB LT 1 BLK 17 OF AN UNRECORDED PLAT OR 6314 P 867 CASE # 2006 CP 2295 CA 160



CERTIFICATION OF TAX DEED APPLICATION

Sections 197.502 and 197.542, Florida Statutes

DR-513
Rule 12D-16.002 F.A.C
Effective 07/19
Page 1 of 2

1223.29

Part 1: Tax Deed Application Information					
Applicant Name Applicant Address	JUAN C CAPOTE MIKON FINANCIAL SERVICES, INC. AND OCEAN BANK 780 NW 42 AVE #300 MIAMI, FL 33126	Application date	Apr 26, 2023		
Property description	PITMAN JERRY TRUSTEE FOR TRUST IN THE LAST WILL & TESTAMENT C/O LYNE PITMAN 301 N PINWOOD LN PENSACOLA, FL 32507 301 N PINWOOD LN 07-4448-050 BEG AT INTER OF W LI OF 1ST ST AND N LI OF THIRD AVE NLY 360 FT FOR POB W 60 FT N TO BAYOU ELY ALG B (Full legal attached.)	Certificate #	2021 / 3154		
		Date certificate issued	06/01/2021		
Part 2: Certificates Owned by Applicant and Filed with Tax Deed Application					
Column 1 Certificate Number	Column 2 Date of Certificate Sale	Column 3 Face Amount of Certificate	Column 4 Interest	Column 5: Total (Column 3 + Column 4)	
# 2021/3154	06/01/2021	1,336.61	66.83	1,403.44	
→ Part 2: Total*				1,403.44	
Part 3: Other Certificates Redeemed by Applicant (Other than County)					
Column 1 Certificate Number	Column 2 Date of Other Certificate Sale	Column 3 Face Amount of Other Certificate	Column 4 Tax Collector's Fee	Column 5 Interest	Total (Column 3 + Column 4 + Column 5)
# 2022/3406	06/01/2022	1,370.93	6.25	68.55	1,445.73
Part 3: Total*					1,445.73
Part 4: Tax Collector Certified Amounts (Lines 1-7)					
1. Cost of all certificates in applicant's possession and other certificates redeemed by applicant (*Total of Parts 2 + 3 above)				2,849.17	
2. Delinquent taxes paid by the applicant				0.00	
3. Current taxes paid by the applicant				1,266.15	
4. Property information report fee				200.00	
5. Tax deed application fee				175.00	
6. Interest accrued by tax collector under s.197.542, F.S. (see Tax Collector Instructions, page 2)				0.00	
7. Total Paid (Lines 1-6)				4,490.32	
I certify the above information is true and the tax certificates, interest, property information report fee, and tax collector's fees have been paid, and that the property information statement is attached.					
Sign here:	Escambia, Florida			Date <u>May 8th, 2023</u>	
Signature, Tax Collector or Designee					

Send this certification to the Clerk of Court by 10 days after the date signed. See Instructions on Page 2

+ \$6.25

Section
Map Id:
CA160

Approx.
Acreage:
0.3249

Zoned: 
MDR

Evacuation
& Flood
Information
[Open Report](#)

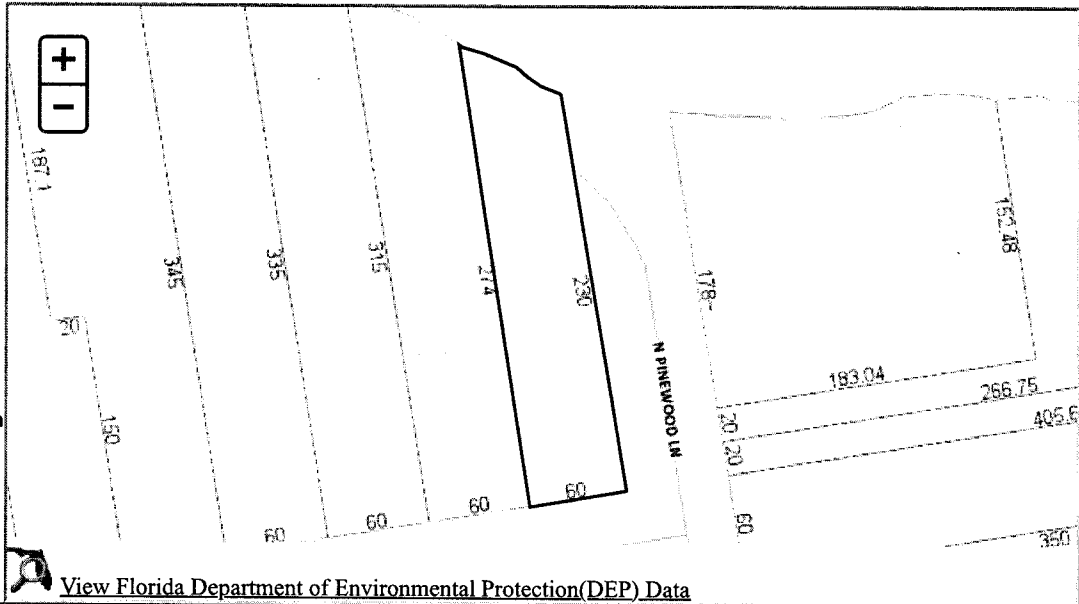

Buildings

Address: 301 N PINWOOD LN, Year Built: 1952, Effective Year: 1965, PA Building ID#: 86219

Structural Elements

- DECOR/MILLWORK-AVERAGE
- DWELLING UNITS-1
- EXTERIOR WALL-CONCRETE BLOCK
- FLOOR COVER-CARPET
- FOUNDATION-SLAB ON GRADE
- HEAT/AIR-CENTRAL H/AC
- INTERIOR WALL-DRYWALL-PLASTER
- INTERIOR WALL-PANEL-PLYWOOD
- NO. PLUMBING FIXTURES-6
- NO. STORIES-1
- ROOF COVER-COMPOSITION SHG
- ROOF FRAMING-GABL/HIP COMBO
- STORY HEIGHT-0
- STRUCTURAL FRAME-MASONRY PIL/STL

 Areas - 2747 Total SF

BASE AREA - 2059
CARPORT UNF - 380
OPEN PORCH FIN - 308

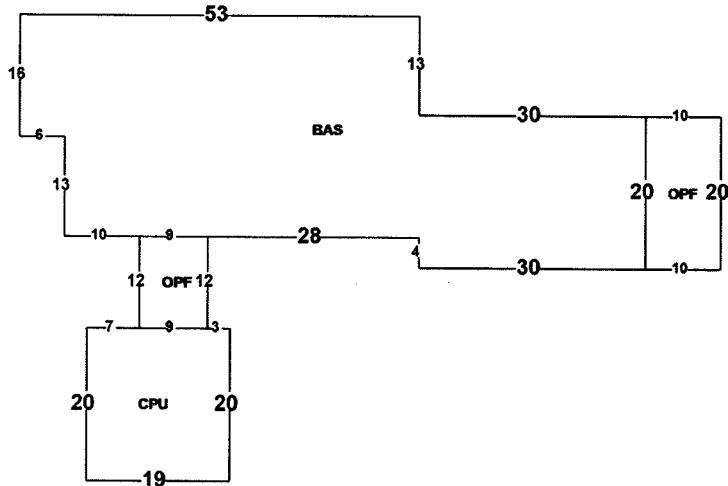

Images

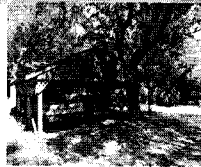

6/23/2016 12:00:00 AM

The primary use of the assessment data is for the preparation of the current year tax roll. No responsibility or liability is assumed for inaccuracies or errors.



Chris Jones Escambia County Property Appraiser

Real Estate Search

Tangible Property Search

Sale List

← Nav. Mode Account Parcel ID →

[Printer Friendly Version](#)

General Information Parcel ID: 382S301001010017 Account: 074448050 Owners: PITMAN JERRY TRUSTEE FOR TRUST IN THE LAST WILL & TESTAMENT OF ELMER W PTIMAN JR Mail: C/O LYNE PITMAN 301 N PINWOOD LN PENSACOLA, FL 32507 Situs: 301 N PINWOOD LN 32507 Use Code: SINGLE FAMILY RESID Taxing Authority: COUNTY MSTU Tax Inquiry: Open Tax Inquiry Window Tax Inquiry link courtesy of Scott Lunsford Escambia County Tax Collector					Assessments <table border="1"> <thead> <tr> <th>Year</th> <th>Land</th> <th>Imprv</th> <th>Total</th> <th>Cap_Val</th> </tr> </thead> <tbody> <tr> <td>2022</td> <td>\$42,720</td> <td>\$124,725</td> <td>\$167,445</td> <td>\$122,561</td> </tr> <tr> <td>2021</td> <td>\$42,720</td> <td>\$103,982</td> <td>\$146,702</td> <td>\$118,992</td> </tr> <tr> <td>2020</td> <td>\$42,720</td> <td>\$91,910</td> <td>\$134,630</td> <td>\$117,350</td> </tr> </tbody> </table> <p style="text-align: center;">Disclaimer</p> <p style="text-align: center;">Tax Estimator</p> <p style="text-align: center;">File for New Homestead Exemption Online</p>					Year	Land	Imprv	Total	Cap_Val	2022	\$42,720	\$124,725	\$167,445	\$122,561	2021	\$42,720	\$103,982	\$146,702	\$118,992	2020	\$42,720	\$91,910	\$134,630	\$117,350																
Year	Land	Imprv	Total	Cap_Val																																									
2022	\$42,720	\$124,725	\$167,445	\$122,561																																									
2021	\$42,720	\$103,982	\$146,702	\$118,992																																									
2020	\$42,720	\$91,910	\$134,630	\$117,350																																									
Sales Data <table border="1"> <thead> <tr> <th>Sale Date</th> <th>Book</th> <th>Page</th> <th>Value</th> <th>Type</th> <th>Official Records (New Window)</th> </tr> </thead> <tbody> <tr> <td>04/01/2008</td> <td>6314</td> <td>867</td> <td>\$100</td> <td>CJ</td> <td></td> </tr> <tr> <td>01/1975</td> <td>897</td> <td>192</td> <td>\$100</td> <td>WD</td> <td></td> </tr> <tr> <td>01/1972</td> <td>646</td> <td>540</td> <td>\$13,200</td> <td>WD</td> <td></td> </tr> <tr> <td>01/1971</td> <td>523</td> <td>797</td> <td>\$13,100</td> <td>WD</td> <td></td> </tr> <tr> <td>01/1969</td> <td>428</td> <td>773</td> <td>\$13,000</td> <td>WD</td> <td></td> </tr> </tbody> </table> Official Records Inquiry courtesy of Pam Childers Escambia County Clerk of the Circuit Court and Comptroller					Sale Date	Book	Page	Value	Type	Official Records (New Window)	04/01/2008	6314	867	\$100	CJ		01/1975	897	192	\$100	WD		01/1972	646	540	\$13,200	WD		01/1971	523	797	\$13,100	WD		01/1969	428	773	\$13,000	WD		2022 Certified Roll Exemptions HOMESTEAD EXEMPTION <hr/> Legal Description BEG AT INTER OF W LI OF 1ST ST AND N LI OF THIRD AVE NLY 360 FT FOR POB W 60 FT N TO BAYOU ELY ALG BAYOU TO W LI... <hr/> Extra Features BOAT DOCK BOAT HOUSE FRAME BUILDING FRAME SHED METAL SHED				
Sale Date	Book	Page	Value	Type	Official Records (New Window)																																								
04/01/2008	6314	867	\$100	CJ																																									
01/1975	897	192	\$100	WD																																									
01/1972	646	540	\$13,200	WD																																									
01/1971	523	797	\$13,100	WD																																									
01/1969	428	773	\$13,000	WD																																									
Parcel Information					Launch Interactive Map																																								

Pam Childers
CLERK OF THE CIRCUIT COURT
ESCAMBIA COUNTY FLORIDA
INST# 2023037779 5/11/2023 3:40 PM
OFF REC BK: 8975 PG: 1845 Doc Type: TDN

NOTICE OF APPLICATION FOR TAX DEED

NOTICE IS HEREBY GIVEN, That **MIKON FINANCIAL SERVICES INC AND OCEAN BANK** holder of **Tax Certificate No. 03154**, issued the **1st** day of **June, A.D., 2021** has filed same in my office and has made application for a tax deed to be issued thereon. Said certificate embraces the following described property in the County of Escambia, State of Florida, to wit:

BEG AT INTER OF W LI OF 1ST ST AND N LI OF THIRD AVE NLY 360 FT FOR POB W 60 FT N TO BAYOU ELY ALG BAYOU TO W LI OF 1ST ST SLY ALG 1ST ST 230 FT TO POB LT 1 BLK 17 OF AN UNRECORDED PLAT OR 6314 P 867 CASE # 2006 CP 2295 CA 160

SECTION 38, TOWNSHIP 2 S, RANGE 30 W

TAX ACCOUNT NUMBER 074448050 (1223-29)

The assessment of the said property under the said certificate issued was in the name of

JERRY PITMAN TRUSTEE and ELMER W PITMAN JR TRUST

Unless said certificate shall be redeemed according to law, the property described therein will be sold to the highest bidder at public auction at 9:00 A.M. on the **first** Wednesday in the month of December, which is the **6th day of December 2023**.

Dated this 10th day of May 2023.

In accordance with the AMERICANS WITH DISABILITIES ACT, if you are a person with a disability who needs special accommodation in order to participate in this proceeding you are entitled to the provision of certain assistance. Please contact Emily Hogg not later than seven days prior to the proceeding at Escambia County Government Complex, 221 Palafox Place Ste 110, Pensacola FL 32502. Telephone: 850-595-3793.



PAM CHILDERS
CLERK OF THE CIRCUIT COURT
ESCAMBIA COUNTY, FLORIDA

By:
Emily Hogg
Deputy Clerk



PROPERTY INFORMATION REPORT
3050 Concho Drive, Pensacola, Florida 32507 | Phone: 850-466-3077

THE ATTACHED REPORT IS ISSUED TO:

SCOTT LUNSFORD, ESCAMBIA COUNTY TAX COLLECTOR

TAX ACCOUNT #: 07-4448-050 CERTIFICATE #: 2021-3154

THIS REPORT IS NOT TITLE INSURANCE. THE LIABILITY FOR ERRORS OR OMISSIONS IN THIS REPORT IS LIMITED TO THE PERSON(S) EXPRESSLY IDENTIFIED BY NAME IN THE PROPERTY INFORMATION REPORT AS THE RECIPIENT(S) OF THE PROPERTY INFORMATION REPORT.

The attached Report prepared in accordance with the instructions given by the user named above includes a listing of the owner(s) of record of the land described herein together with current and delinquent ad valorem tax information and a listing and copies of all open or unsatisfied leases, mortgages, judgments and encumbrances recorded in the Official Record Books of Escambia County, Florida that appear to encumber the title to said land as listed on page 2 herein. It is the responsibility of the party named above to verify receipt of each document listed. If a copy of any document listed is not received, the office issuing this Report must be contacted immediately.

This Report is subject to: Current year taxes; taxes and assessments due now or in subsequent years; oil, gas, and mineral or any subsurface rights of any kind or nature; easements, restrictions and covenants of record; encroachments, overlaps, boundary line disputes, and any other matters that would be disclosed by an accurate survey and inspection of the premises.

This Report does not insure or guarantee the validity or sufficiency of any document attached, nor is it to be considered a title insurance policy, an opinion of title, a guarantee of title, or as any other form of guarantee or warranty of title.

Use of the term "Report" herein refers to the Property Information Report and the documents attached hereto.

Period Searched: August 28, 2003 to and including August 28, 2023 Abstractor: Vicki Campbell

BY

Michael A. Campbell,
As President
Dated: August 29, 2023

PROPERTY INFORMATION REPORT
CONTINUATION PAGE

August 29, 2023

Tax Account #: **07-4448-050**

1. The Grantee(s) of the last deed(s) of record is/are: **JERRY PITMAN, AS TRUSTEE OF THE TRUST IN THE LAST WILL & TESTAMENT OF ELMER W. PITMAN, JR.,**

By Virtue of Personal Representative's Deed recorded 4/15/2008 in OR 6314/867

ABTRACTOR'S NOTE: INCLUDED FOR YOUR INFORMATION COPY OF LW&T OF ELMER W. PITMAN, JR. WE FIND NO PROOF OF DEATH OF LYNE MARIE PITMAN AND WE HAVE INCLUDED ALL HEIRS OF ELMER W. PITMAN, JR. FOR NOTIFICATION.

2. The land covered by this Report is: **See Attached Exhibit "A"**
3. The following unsatisfied mortgages, liens, and judgments affecting the land covered by this Report appear of record:
 - a. **NONE**

4. Taxes:

Taxes for the year(s) 2020-2022 are delinquent.

Tax Account #: 07-4448-050

Assessed Value: \$122,561.00

Exemptions: HOMESTEAD

5. We find the following HOA names in our search (if a condominium, the condo docs book and page are included for your review): **NONE**

Payment of any special liens/assessments imposed by City, County, and/or State.

Note: Escambia County and/or local municipalities may impose special liens/assessments. These liens/assessments are not discovered in a title search or shown above. These special assessments typically create a lien on real property. The entity that governs subject property must be contacted to verify payment status.

PERDIDO TITLE & ABSTRACT, INC.
PROPERTY INFORMATION REPORT
3050 Concho Drive, Pensacola, Florida 32507 | Phone 850-466-3077

Scott Lunsford
Escambia County Tax Collector
P.O. Box 1312
Pensacola, FL 32591

CERTIFICATION: TITLE SEARCH FOR TDA

TAX DEED SALE DATE: _____ **DEC 6, 2023**
TAX ACCOUNT #: _____ **07-4448-050**
CERTIFICATE #: _____ **2021-3154**

In compliance with Section 197.522, Florida Statutes, the following is a list of names and addresses of those persons, firms, and/or agencies having legal interest in or claim against the above-described property. The above-referenced tax sale certificate is being submitted as proper notification of tax deed sale.

- | YES | NO | |
|-------------------------------------|-------------------------------------|--|
| <input type="checkbox"/> | <input checked="" type="checkbox"/> | Notify City of Pensacola, P.O. Box 12910, 32521 |
| <input type="checkbox"/> | <input checked="" type="checkbox"/> | Notify Escambia County, 190 Governmental Center, 32502 |
| <input checked="" type="checkbox"/> | <input type="checkbox"/> | Homestead for <u>2022</u> tax year. |

**JERRY PITMAN AS TRUSTEE OF
THE TRUST IN THE LAST WILL &
TESTAMENT OF ELMER W. PITMAN, JR.,
11440 EMPIRE GRADE ROAD
SANT CRUZ, CA 95060-9645**

**JERRY PITMAN AS TRUSTEE OF
THE TRUST IN THE LAST WILL &
TESTAMENT OF ELMER W. PITMAN, JR.,
AND LYNE PITMAN
301 N PINWOOD LN.
PENSACOLA, FL 32507**

Certified and delivered to Escambia County Tax Collector, this 29th day of September, 2023.

PERDIDO TITLE & ABSTRACT, INC.



BY: Michael A. Campbell, As It's President

NOTE: The above listed addresses are based upon current information available, but addresses are not guaranteed to be true or correct.

PROPERTY INFORMATION REPORT

August 29, 2023

Tax Account #:07-4448-050

**LEGAL DESCRIPTION
EXHIBIT "A"**

**BEG AT INTER OF W LI OF 1ST ST AND N LI OF THIRD AVE NLY 360 FT FOR POB W 60 FT N
TO BAYOU ELY ALG BAYOU TO W LI OF 1ST ST SLY ALG 1ST ST 230 FT TO POB LT 1 BLK 17
OF AN UNRECORDED PLAT OR 6314 P 867 CASE # 2006 CP 2295 CA 160**

SECTION 38, TOWNSHIP 2 S, RANGE 30 W

TAX ACCOUNT NUMBER 07-4448-050(1223-29)

PERSONAL REPRESENTATIVE'S DEED

(testate--single personal representative)

THIS INDENTURE, made this 1st day of April, 2008, by
and between LYNE MARIE PITMAN, whose address is 127 Cavalier Drive, Pensacola, Florida
32507, the duly qualified and acting personal representative of the estate ELMER WALLACE
PITMAN, JR., deceased, party of the first part and JERRY PITMAN, as Trustee of The Trust in the
Last Will & Testament of Elmer W. Pitman, Jr., whose address is 11440 Empire Grade Road,
Santa Cruz, CA 95060-9645, party of the second part.

WITNESSETH: That WHEREAS, ELMER WALLACE PITMAN, JR., died testate a resident
of Escambia County, Florida on October 31, 2006, seized and possessed of the real property
hereinafter described; and

WHEREAS, title to said property passed to the party of the second part as of the date of
said decedent's death pursuant to the provisions of the decedent's Last Will and Testament, which
was admitted to probate and recorded by the Circuit Court for Escambia County, Florida, Probate
Division, in Case No: 2006 CP 002295, Notice of Trust recorded by the Circuit Court for Escambia
County, Florida, Probate Division, in Case No: 2006 CP 002383, and Letters of Administration
were entered on January 9, 2007, subject only to the right of the party of the first part to sell or
encumber the property for the purpose of defraying claims, costs and expenses of administration
of the decedent's estate; and

WHEREAS, the party of the first part wishes to distribute said property to the party of the
second part and evidence the release of the property from said right to sell or encumber;

NOW THEREFORE, in consideration of the foregoing and in connection with the distribution
of the estate of said decedent, the party of the first part has released to the party of the second part
the right to sell or encumber said property and granted, conveyed and confirmed unto the party of
the second part, their heirs and assigns forever, all of the interest of said decedent in and to the
real property situated in Escambia County, Florida, described as follows:

301 North Pinewood Lane, Pensacola, Florida 32507, further described as:

Beginning at the Northwest corner of the intersection of First Street and Third Avenue, in
Westerly Heights, according to Plat recorded in Plat Book 2, at page 14, of the Public
Records of Escambia County, Florida; thence run in a Northerly direction along the West
line of First Street a distance of 360.0 feet for the point of beginning of this description;
thence Westerly parallel to the North line of Third Avenue a distance of 60.0 feet; thence
Northerly parallel to First Street to the Bayou Chico Shore line; then Easterly along Bayou
Chico Shore line to the West line of First Street; thence Southerly on West line of First
Street 230.0 feet, more or less, to the point of beginning. All in Section 38, Township 2
South, Range 30 West, Escambia County, Florida. PARCEL ID: 38-2S-30-1001-010-017

127 Cavalier Drive, Pensacola, Florida 32507, further described as:

Lot 12, Block 7, Corry Subdivision, a subdivision of a portion of Sections 50 and 51,
Township 2 South, Range 30 West, Escambia County, Florida, according to plat recorded
in Plat Book 1, Page 55, of the public records of said county.
PARCEL ID: 50-2S-30-5060-012-007

615 West Sunset Avenue, Pensacola, Florida 32507, further described as:

Lot 9, Block 1, Navy Point, being a portion of Section 50, Township 2 South, Range 30
West, Escambia County, Florida, according to plat recorded in Plat Book 1, Page 100 ABC,
of the public records of said county.
PARCEL ID: 50-2S-30-6090-009-001

TOGETHER with all and singular the tenements, hereditament and appurtenances
belonging to or in any way appertaining to that real property, subject to all restriction, reservations
and easements of record, if any, and ad valorem taxes for the current year.

Because this deed is given to evidence the distribution of assets of a decedent's estate and involves the assumption of no mortgage, minimum state documentary stamps are affixed.
IN WITNESS WHEREOF, the undersigned as personal representative of the estate of the said decedent, has executed this instrument under seal on the date aforesaid.

Signed, sealed and delivered in the presence of:

Steve M. Shenesty
WITNESS- STEVE M. SHENESTY
Glennnda B. Harold
WITNESS- Glennnda B. Harold

Lyne Marie Pitman
LYNE MARIE PITMAN, as
PERSONAL REPRESENTATIVE of the
Estate of ELMER WALLACE PITMAN, JR.,
Deceased

STATE OF FLORIDA
COUNTY OF ESCAMBA

I HEREBY CERTIFY that the foregoing instrument was acknowledged before me on this 1st day of April, 2008, by LYNE MARIE PITMAN, as personal representative of the Estate of ELMER WALLACE PITMAN, JR., deceased, and who produced Florida Drivers License #P355-533-62-905-0 as identification and who did take an oath.

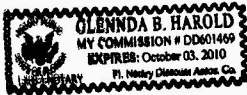

Glennnda B. Harold
NOTARY PUBLIC, State of Florida

This instrument prepared by:

James W. Magaha, Esquire
Florida Bar No. 394327
812 N. Spring Street
Pensacola, Florida 32501
(850) 438-6224



**STATE OF FLORIDA
COUNTY OF ESCAMBIA**

**CERTIFICATE OF NOTICE OF MAILING
NOTICE OF APPLICATION FOR TAX DEED**

CERTIFICATE # 03154 of 2021

I, PAM CHILDERS, CLERK OF THE CIRCUIT COURT OF ESCAMBIA COUNTY, FLORIDA, do hereby certify that I did on October 19, 2023, mail a copy of the foregoing Notice of Application for Tax Deed, addressed to:

JERRY PITMAN TRUSTEE ELMER W PITMAN JR TRUST
C/O LYNE PITMAN C/O LYNE PITMAN
301 N PINWOOD LN 301 N PINWOOD LN
PENSACOLA, FL 32507 PENSACOLA, FL 32507

JERRY PITMAN TRUSTEE ELMER W PITMAN JR TRUST
11440 EMPIRE GRADE ROAD 11440 EMPIRE GRADE ROAD
SANTA CRUZ CA 95060 SANTA CRUZ CA 95060

LYNN MARIE PITMAN
127 CAVALIER DR
PENSACOLA FL 32507

WITNESS my official seal this 19th day of October 2023.

PAM CHILDERS
CLERK OF THE CIRCUIT COURT
ESCAMBIA COUNTY, FLORIDA

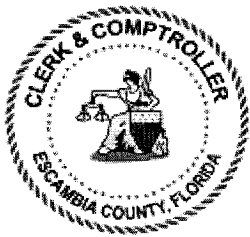

By:
Emily Hogg
Deputy Clerk

WARNING

THERE ARE UNPAID TAXES ON PROPERTY WHICH YOU OWN OR IN WHICH YOU HAVE A LEGAL INTEREST. THE PROPERTY WILL BE SOLD AT PUBLIC AUCTION ON December 6, 2023, UNLESS THE TAXES ARE PAID. SHOULD YOU NEED FURTHER INFORMATION CONTACT THE CLERK OF THE CIRCUIT COURT IMMEDIATELY AT THE COUNTY COURTHOUSE IN PENSACOLA, FLORIDA, OR CALL 850-595-3793.

NOTICE OF APPLICATION FOR TAX DEED

NOTICE IS HEREBY GIVEN, That **MIKON FINANCIAL SERVICES INC AND OCEAN BANK** holder of **Tax Certificate No. 03154**, issued the **1st** day of **June, A.D., 2021** has filed same in my office and has made application for a tax deed to be issued thereon. Said certificate embraces the following described property in the County of Escambia, State of Florida, to wit:

BEG AT INTER OF W LI OF 1ST ST AND N LI OF THIRD AVE NLY 360 FT FOR POB W 60 FT N TO BAYOU ELY ALG BAYOU TO W LI OF 1ST ST SLY ALG 1ST ST 230 FT TO POB LT 1 BLK 17 OF AN UNRECORDED PLAT OR 6314 P 867 CASE # 2006 CP 2295 CA 160

SECTION 38, TOWNSHIP 2 S, RANGE 30 W

TAX ACCOUNT NUMBER 074448050 (1223-29)

The assessment of the said property under the said certificate issued was in the name of

JERRY PITMAN TRUSTEE and ELMER W PITMAN JR TRUST

Unless said certificate shall be redeemed according to law, the property described therein will be sold to the highest bidder at public auction at 9:00 A.M. on the **first** Wednesday in the month of December, which is the **6th day of December 2023**.

Dated this 16th day of October 2023.

In accordance with the AMERICANS WITH DISABILITIES ACT, if you are a person with a disability who needs special accommodation in order to participate in this proceeding you are entitled to the provision of certain assistance. Please contact Emily Hogg not later than seven days prior to the proceeding at Escambia County Government Complex, 221 Palafox Place Ste 110, Pensacola FL 32502. Telephone: 850-595-3793.

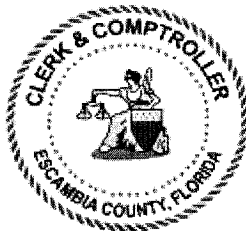

PAM CHILDERS
CLERK OF THE CIRCUIT COURT
ESCAMBIA COUNTY, FLORIDA

By:
Emily Hogg
Deputy Clerk

WARNING

THERE ARE UNPAID TAXES ON PROPERTY WHICH YOU OWN OR IN WHICH YOU HAVE A LEGAL INTEREST. THE PROPERTY WILL BE SOLD AT PUBLIC AUCTION ON December 6, 2023, UNLESS THE TAXES ARE PAID. SHOULD YOU NEED FURTHER INFORMATION CONTACT THE CLERK OF THE CIRCUIT COURT IMMEDIATELY AT THE COUNTY COURTHOUSE IN PENSACOLA, FLORIDA, OR CALL 850-595-3793.

NOTICE OF APPLICATION FOR TAX DEED

NOTICE IS HEREBY GIVEN, That **MIKON FINANCIAL SERVICES INC AND OCEAN BANK** holder of **Tax Certificate No. 03154**, issued the **1st day of June, A.D., 2021** has filed same in my office and has made application for a tax deed to be issued thereon. Said certificate embraces the following described property in the County of Escambia, State of Florida, to wit:

BEG AT INTER OF W LI OF 1ST ST AND N LI OF THIRD AVE NLY 360 FT FOR POB W 60 FT N TO BAYOU ELY ALG BAYOU TO W LI OF 1ST ST SLY ALG 1ST ST 230 FT TO POB LT 1 BLK 17 OF AN UNRECORDED PLAT OR 6314 P 867 CASE # 2006 CP 2295 CA 160

SECTION 38, TOWNSHIP 2 S, RANGE 30 W

TAX ACCOUNT NUMBER 074448050 (1223-29)

The assessment of the said property under the said certificate issued was in the name of

JERRY PITMAN TRUSTEE and ELMER W PITMAN JR TRUST

Unless said certificate shall be redeemed according to law, the property described therein will be sold to the highest bidder at public auction at 9:00 A.M. on the **first** Wednesday in the month of December, which is the **6th day of December 2023**.

Dated this 9th day of October 2023.

In accordance with the AMERICANS WITH DISABILITIES ACT, if you are a person with a disability who needs special accommodation in order to participate in this proceeding you are entitled to the provision of certain assistance. Please contact Emily Hogg not later than seven days prior to the proceeding at Escambia County Government Complex, 221 Palafox Place Ste 110, Pensacola FL 32502. Telephone: 850-595-3793.

Post Property:

301 N PINWOOD LN 32507



PAM CHILDERS
CLERK OF THE CIRCUIT COURT
ESCAMBIA COUNTY, FLORIDA

By:
Emily Hogg
Deputy Clerk

WARNING

THERE ARE UNPAID TAXES ON PROPERTY WHICH YOU OWN OR IN WHICH YOU HAVE A LEGAL INTEREST. THE PROPERTY WILL BE SOLD AT PUBLIC AUCTION ON December 6, 2023, UNLESS THE TAXES ARE PAID. SHOULD YOU NEED FURTHER INFORMATION CONTACT THE CLERK OF THE CIRCUIT COURT IMMEDIATELY AT THE COUNTY COURTHOUSE IN PENSACOLA, FLORIDA, OR CALL 850-595-3793.

NOTICE OF APPLICATION FOR TAX DEED

NOTICE IS HEREBY GIVEN, That **MIKON FINANCIAL SERVICES INC AND OCEAN BANK** holder of **Tax Certificate No. 03154**, issued the 1st day of **June, A.D., 2021** has filed same in my office and has made application for a tax deed to be issued thereon. Said certificate embraces the following described property in the County of Escambia, State of Florida, to wit:

BEG AT INTER OF W LI OF 1ST ST AND N LI OF THIRD AVE NLY 360 FT FOR POB W 60 FT N TO BAYOU ELY ALG BAYOU TO W LI OF 1ST ST SLY ALG 1ST ST 230 FT TO POB LT 1 BLK 17 OF AN UNRECORDED PLAT OR 6314 P 867 CASE # 2006 CP 2295 CA 160

SECTION 38, TOWNSHIP 2 S, RANGE 30 W

TAX ACCOUNT NUMBER 074448050 (1223-29)

The assessment of the said property under the said certificate issued was in the name of

JERRY PITMAN TRUSTEE and ELMER W PITMAN JR TRUST

Unless said certificate shall be redeemed according to law, the property described therein will be sold to the highest bidder at public auction at 9:00 A.M. on the **first** Wednesday in the month of December, which is the **6th day of December 2023**.

Dated this 9th day of October 2023.

In accordance with the AMERICANS WITH DISABILITIES ACT, if you are a person with a disability who needs special accommodation in order to participate in this proceeding you are entitled to the provision of certain assistance. Please contact Emily Hogg not later than seven days prior to the proceeding at Escambia County Government Complex, 221 Palafox Place Ste 110, Pensacola FL 32502. Telephone: 850-595-3793.

Personal Services:

JERRY PITMAN TRUSTEE
C/O LYNE PITMAN
301 N PINWOOD LN
PENSACOLA, FL 32507

PAM CHILDERS
CLERK OF THE CIRCUIT COURT
ESCAMBIA COUNTY, FLORIDA

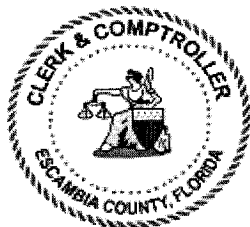

By:
Emily Hogg
Deputy Clerk

WARNING

THERE ARE UNPAID TAXES ON PROPERTY WHICH YOU OWN OR IN WHICH YOU HAVE A LEGAL INTEREST. THE PROPERTY WILL BE SOLD AT PUBLIC AUCTION ON December 6, 2023, UNLESS THE TAXES ARE PAID. SHOULD YOU NEED FURTHER INFORMATION CONTACT THE CLERK OF THE CIRCUIT COURT IMMEDIATELY AT THE COUNTY COURTHOUSE IN PENSACOLA, FLORIDA, OR CALL 850-595-3793.

NOTICE OF APPLICATION FOR TAX DEED

NOTICE IS HEREBY GIVEN, That **MIKON FINANCIAL SERVICES INC AND OCEAN BANK** holder of **Tax Certificate No. 03154**, issued the 1st day of **June, A.D., 2021** has filed same in my office and has made application for a tax deed to be issued thereon. Said certificate embraces the following described property in the County of Escambia, State of Florida, to wit:

BEG AT INTER OF W LI OF 1ST ST AND N LI OF THIRD AVE NLY 360 FT FOR POB W 60 FT N TO BAYOU ELY ALG BAYOU TO W LI OF 1ST ST SLY ALG 1ST ST 230 FT TO POB LT 1 BLK 17 OF AN UNRECORDED PLAT OR 6314 P 867 CASE # 2006 CP 2295 CA 160

SECTION 38, TOWNSHIP 2 S, RANGE 30 W

TAX ACCOUNT NUMBER 074448050 (1223-29)

The assessment of the said property under the said certificate issued was in the name of

JERRY PITMAN TRUSTEE and ELMER W PITMAN JR TRUST

Unless said certificate shall be redeemed according to law, the property described therein will be sold to the highest bidder at public auction at 9:00 A.M. on the **first** Wednesday in the month of December, which is the **6th day of December 2023**.

Dated this 9th day of October 2023.

In accordance with the AMERICANS WITH DISABILITIES ACT, if you are a person with a disability who needs special accommodation in order to participate in this proceeding you are entitled to the provision of certain assistance. Please contact Emily Hogg not later than seven days prior to the proceeding at Escambia County Government Complex, 221 Palafox Place Ste 110, Pensacola FL 32502. Telephone: 850-595-3793.

Personal Services:

ELMER W PITMAN JR TRUST
C/O LYNE PITMAN
301 N PINWOOD LN
PENSACOLA, FL 32507

PAM CHILDERS
CLERK OF THE CIRCUIT COURT
ESCAMBIA COUNTY, FLORIDA



By:
Emily Hogg
Deputy Clerk

ESCAMBIA COUNTY SHERIFF'S OFFICE
ESCAMBIA COUNTY, FLORIDA

NON-ENFORCEABLE RETURN OF SERVICE 123-29

Document Number: ECSO23CIV038116NON

Agency Number: 24-000517

Court: TAX DEED

County: ESCAMBIA

Case Number: CERT NO 03154 2021

Attorney/Agent:

PAM CHILDERS
CLERK OF COURT
TAX DEED

Plaintiff: RE: JERRY PITMAN TRUSTEE AND ELMER W PITMAN JR TRUST

Defendant:

Type of Process: NOTICE OF APPLICATION FOR TAX DEED

Received this Writ on 10/20/2023 at 9:32 AM and served same at 3:53 PM on 10/24/2023 in ESCAMBIA COUNTY, FLORIDA, by serving POST PROPERTY , the within named, to wit: , .

POSTED TO PROPERTY PER CLERKS OFFICE INSTRUCTIONS

CHIP W SIMMONS, SHERIFF
ESCAMBIA COUNTY, FLORIDA

By: _____

C Davis 927

C. DAVIS, CPS

Service Fee: \$40.00

Receipt No: BILL

Printed By: MRM

ESCAMBIA COUNTY SHERIFF'S OFFICE
ESCAMBIA COUNTY, FLORIDA

NON-ENFORCEABLE RETURN OF SERVICE

1223-29

Document Number: ECSO23CIV038117NON

Agency Number: 24-000518

Court: TAX DEED

County: ESCAMBIA

Case Number: CERT NO 03154 2021

Attorney/Agent:

PAM CHILDERS
CLERK OF COURT
TAX DEED

Plaintiff: RE: JERRY PITMAN TRUSTEE AND ELMER W PITMAN JR TRUST

Defendant:

Type of Process: NOTICE OF APPLICATION FOR TAX DEED

Received this Writ on 10/20/2023 at 9:32 AM and served same at 3:53 PM on 10/24/2023 in ESCAMBIA COUNTY, FLORIDA, by serving ELMER W PITMAN JR TRUST , the within named, to wit: LYNE PITMAN, DAUGHTER IN LAW.

CHIP W SIMMONS, SHERIFF
ESCAMBIA COUNTY, FLORIDA

By: _____

C Davis 927

C. DAVIS, CPS

Service Fee: \$40.00

Receipt No: BILL

Printed By: MRM

300510

WARNING

THERE ARE UNPAID TAXES ON PROPERTY WHICH YOU OWN OR IN WHICH YOU HAVE A LEGAL INTEREST. THE PROPERTY WILL BE SOLD AT PUBLIC AUCTION ON December 6, 2023, UNLESS THE TAXES ARE PAID. SHOULD YOU NEED FURTHER INFORMATION CONTACT THE CLERK OF THE CIRCUIT COURT IMMEDIATELY AT THE COUNTY COURTHOUSE IN PENSACOLA, FLORIDA, OR CALL 850-595-3793.

NOTICE OF APPLICATION FOR TAX DEED

NOTICE IS HEREBY GIVEN, That MIKON FINANCIAL SERVICES INC AND OCEAN BANK holder of Tax Certificate No. 03154, issued the 1st day of June, A.D., 2021 has filed same in my office and has made application for a tax deed to be issued thereon. Said certificate embraces the following described property in the County of Escambia, State of Florida, to wit:

BEG AT INTER OF W LI OF 1ST ST AND N LI OF THIRD AVE NLY 360 FT FOR POB W 60 FT N TO BAYOU ELY ALG BAYOU TO W LI OF 1ST ST SLY ALG 1ST ST 230 FT TO POB LT 1 BLK 17 OF AN UNRECORDED PLAT OR 6314 P 867 CASE # 2006 CP 2295 CA 160

SECTION 38, TOWNSHIP 2 S, RANGE 30 W

TAX ACCOUNT NUMBER 074448050 (1223-29)

The assessment of the said property under the said certificate issued was in the name of

JERRY PITMAN TRUSTEE and ELMER W PITMAN JR TRUST

Unless said certificate shall be redeemed according to law, the property described therein will be sold to the highest bidder at public auction at 9:00 A.M. on the **first** Wednesday in the month of December, which is the **6th day of December 2023.**

Dated this 9th day of October 2023.

In accordance with the AMERICANS WITH DISABILITIES ACT, if you are a person with a disability who needs special accommodation in order to participate in this proceeding you are entitled to the provision of certain assistance. Please contact Emily Hogg not later than seven days prior to the proceeding at Escambia County Government Complex, 221 Palafox Place Ste 110, Pensacola FL 32502. Telephone: 850-595-3793.

Personal Services:

ELMER W PITMAN JR TRUST
C/O LYNE PITMAN
301 N PINWOOD LN
PENSACOLA, FL 32507

PAM CHILDERS
CLERK OF THE CIRCUIT COURT
ESCAMBIA COUNTY, FLORIDA



By:
Emily Hogg
Deputy Clerk

ESCAMBIA COUNTY SHERIFF'S OFFICE
ESCAMBIA COUNTY, FLORIDA

NON-ENFORCEABLE RETURN OF SERVICE

1223-29

Document Number: ECSO23CIV038119NON

Agency Number: 24-000519

Court: TAX DEED

County: ESCAMBIA

Case Number: CERT NO 03154 2021

Attorney/Agent:

PAM CHILDERS
CLERK OF COURT
TAX DEED

Plaintiff: RE: JERRY PITMAN TRUSTEE AND ELMER W PITMAN JR TRUST

Defendant:

Type of Process: NOTICE OF APPLICATION FOR TAX DEED

Received this Writ on 10/20/2023 at 9:32 AM and served same at 3:53 PM on 10/24/2023 in ESCAMBIA COUNTY, FLORIDA, by serving JERRY PITMAN TRUSTEE , the within named, to wit: LYNE PITMAN, SPOUSE.

CHIP W SIMMONS, SHERIFF
ESCAMBIA COUNTY, FLORIDA

By: _____

C Davis 927

C. DAVIS, CPS

Service Fee: \$40.00

Receipt No: BILL

Printed By: MRM

000519

WARNING

THERE ARE UNPAID TAXES ON PROPERTY WHICH YOU OWN OR IN WHICH YOU HAVE A LEGAL INTEREST. THE PROPERTY WILL BE SOLD AT PUBLIC AUCTION ON December 6, 2023, UNLESS THE TAXES ARE PAID. SHOULD YOU NEED FURTHER INFORMATION CONTACT THE CLERK OF THE CIRCUIT COURT IMMEDIATELY AT THE COUNTY COURTHOUSE IN PENSACOLA, FLORIDA, OR CALL 850-595-3793.

NOTICE OF APPLICATION FOR TAX DEED

NOTICE IS HEREBY GIVEN, That **MIKON FINANCIAL SERVICES INC AND OCEAN BANK** holder of **Tax Certificate No. 03154**, issued the 1st day of **June, A.D., 2021** has filed same in my office and has made application for a tax deed to be issued thereon. Said certificate embraces the following described property in the County of Escambia, State of Florida, to wit:

BEG AT INTER OF W LI OF 1ST ST AND N LI OF THIRD AVE NLY 360 FT FOR POB W 60 FT N TO BAYOU ELY ALG BAYOU TO W LI OF 1ST ST SLY ALG 1ST ST 230 FT TO POB LT 1 BLK 17 OF AN UNRECORDED PLAT OR 6314 P 867 CASE # 2006 CP 2295 CA 160

SECTION 38, TOWNSHIP 2 S, RANGE 30 W

TAX ACCOUNT NUMBER 074448050 (1223-29)

The assessment of the said property under the said certificate issued was in the name of

JERRY PITMAN TRUSTEE and ELMER W PITMAN JR TRUST

Unless said certificate shall be redeemed according to law, the property described therein will be sold to the highest bidder at public auction at 9:00 A.M. on the **first** Wednesday in the month of December, which is the **6th day of December 2023.**

Dated this 9th day of October 2023.

In accordance with the AMERICANS WITH DISABILITIES ACT, if you are a person with a disability who needs special accommodation in order to participate in this proceeding you are entitled to the provision of certain assistance. Please contact Emily Hogg not later than seven days prior to the proceeding at Escambia County Government Complex, 221 Palafox Place Ste 110, Pensacola FL 32502. Telephone: 850-595-3793.

Personal Services:

JERRY PITMAN TRUSTEE
C/O LYNE PITMAN
301 N PINWOOD LN
PENSACOLA, FL 32507

PAM CHILDERS
CLERK OF THE CIRCUIT COURT
ESCAMBIA COUNTY, FLORIDA

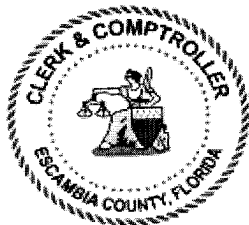

By:
Emily Hogg
Deputy Clerk

000519
9:32

JERRY PITMAN TRUSTEE [1223-29]
C/O LYNE PITMAN
301 N PINWOOD LN
PENSACOLA, FL 32507

9171 9690 0935 0127 2167 56

ELMER W PITMAN JR TRUST [1223-29]
C/O LYNE PITMAN
301 N PINWOOD LN
PENSACOLA, FL 32507

9171 9690 0935 0127 2166 40

JERRY PITMAN TRUSTEE [1223-29]
11440 EMPIRE GRADE ROAD
SANTA CRUZ CA 95060

9171 9690 0935 0127 2166 57

ELMER W PITMAN JR TRUST [1223-29]
11440 EMPIRE GRADE ROAD
SANTA CRUZ CA 95060

9171 9690 0935 0127 2166 64

LYNN MARIE PITMAN [1223-29]
127 CAVALIER DR
PENSACOLA FL 32507

9171 9690 0935 0127 2166 71

Contact - Family
[Handwritten signature]

Pam Childers
Clerk of the Circuit Court & Comptroller
Official Records
221 Palafox Place, Suite 110
Pensacola, FL 32502

CLERK
OFFICIAL RECORDS

UTR

JERRY PITMAN TRUSTEE [1223-29]
11440 EMPIRE GRADE ROAD
SANTA CRUZ CA 95060

CERTIFIED MAIL



9171 9690 0935 0127 2166 57

PENSACOLA FL 325
19 OCT 2023 PM 2:15

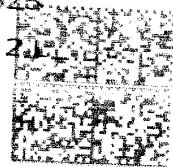

quodient
FIRST-CLASS MAIL
IM1
\$007.18
10/19/2023 ZIP 32502
043M31219251

US POSTAGE

NIXIE 958 FE 1 0011/05/23

RETURN TO SENDER
NOT DELIVERABLE AS ADDRESSED
UNABLE TO FORWARD

UTR
9171 9690 0935 0127 2166 57

BC: 32502583335 *2738-06133-19-38

CERTIFIED MAIL™

10/19/2023 10:27:58 AM
350127216664



PENSACOLA FL 325

OCT 20 3PM 21

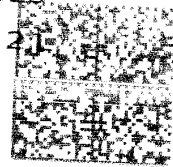

quadrant

FIRST-CLASS MAIL

\$007.18

10/19/2023 ZIP 32501
043M31219251

BIXIN

35 0127 2166 64

US POSTAGE

ELMER W PITMAN JR TRUST [1223-29]
11440 EMPIRE GRADE ROAD
SANTA CRUZ CA 95060

Handwritten signature

2023 OCT 19 10:27:58 AM

3250127216664

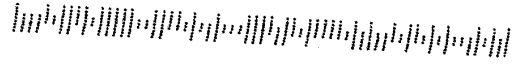

CERTIFIED MAIL™

Pam Childers
Clerk of the Circuit Court & Comptroller
Official Records
221 Palafox Place Suite 110
Pensacola, FL 32502

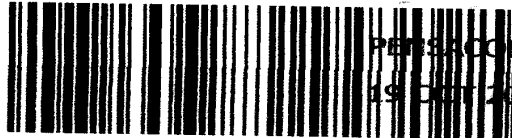

9171 9690 0935 0127 2167 56

PENSACOLA FL 325
19 OCT 2023 PM 2:15

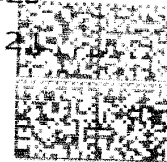

evadient
FIRST-CLASS MAIL
IM1
\$007.18
10/19/2023 ZIP 32502
043M3121923*

US POSTAGE

JERRY PITMAN TRUSTEE [1223-29]
C/O LYNE PITMAN
301 N PINWOOD LN
PENSACOLA, FL 32507

NIXIE

322 DE 1

0011/16/23

RETURN TO SENDER
UNCLAIMED
UNABLE TO FORWARD

UNC

BC: 32502583335

*2738-06658-19-08

301 N PINWOOD LN
PENSACOLA, FL 32507

CERTIFIED MAIL™

Pam Childers
Clerk of the Circuit Court & Comptroller
Official Records
221 Palafox Place, Suite 110
Pensacola, FL 32502

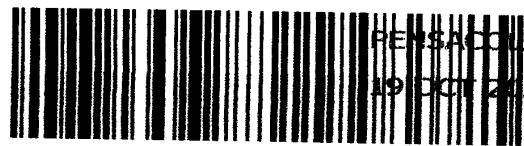

PENSACOLA FL 325
19 OCT 20 23 PM 21

9171 9690 0935 0127 2166 40

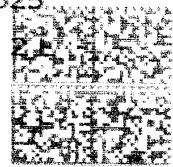

quod/ant
FIRST-CLASS MAIL
IMI
5007.18
10/19/2023 ZIP 32502
043M91219351

US POSTAGE

2023 OCT 20 11:00 AM
2023 OCT 20 11:00 AM
2023 OCT 20 11:00 AM

*LEFT
NOTICE
10-20-23*

ELMER W PITMAN JR TRUST [1223-29]
C/O LYNE PITMAN
301 N PINWOOD LN
PENSACOLA, FL 32507

NIXIE 822 DE 1 @011/16/23

RETURN TO SENDER
UNCLAIMED
UNABLE TO FORWARD

UNC BC: 32502583335 *2738-06212-19-38
32502583335 5007-12660

2

PAM CHILDERS
 CLERK OF THE CIRCUIT COURT
 ARCHIVES AND RECORDS
 CHILDSUPPORT
 CIRCUIT CIVIL
 CIRCUIT CRIMINAL
 COUNTY CIVIL
 COUNTY CRIMINAL
 DOMESTIC RELATIONS
 FAMILY LAW
 JURY ASSEMBLY
 JUVENILE
 MENTAL HEALTH
 MIS
 OPERATIONAL SERVICES
 PROBATE
 TRAFFIC

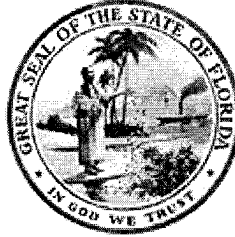

BRANCH OFFICES
ARCHIVES AND RECORDS
JUVENILE DIVISION
CENTURY

CLERK TO THE BOARD OF
 COUNTY COMMISSIONERS
 OFFICIAL RECORDS
 COUNTY TREASURY
 AUDITOR

COUNTY OF ESCAMBIA
OFFICE OF THE
CLERK OF THE CIRCUIT COURT

PAM CHILDERS, CLERK OF THE CIRCUIT COURT
Tax Certificate Redeemed From Sale
Account: 074448050 Certificate Number: 003154 of 2021

Payor: LYNE PITMAN 301 N PINWOOD LN PENSACOLA, FL 32507 Date 11/27/2023

Clerk's Check #	1	Clerk's Total	\$510.72 \$5,471.93
Tax Collector Check #	1	Tax Collector's Total	\$5,033.41
		Postage	\$36.05
		Researcher Copies	\$0.00
		Recording	\$10.00
		Prep Fee	\$7.00
		Total Received	\$5,599.18

PAM CHILDERS
 Clerk of the Circuit Court

Received By:
 Deputy Clerk

\$5,524.98
+ 193.37 card fee
\$5,718.35

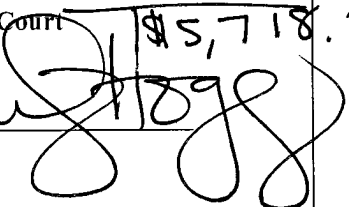

PAM CHILDERS
 CLERK OF THE CIRCUIT COURT
 ARCHIVES AND RECORDS
 CHILDSUPPORT
 CIRCUIT CIVIL
 CIRCUIT CRIMINAL
 COUNTY CIVIL
 COUNTY CRIMINAL
 DOMESTIC RELATIONS
 FAMILY LAW
 JURY ASSEMBLY
 JUVENILE
 MENTAL HEALTH
 MIS
 OPERATIONAL SERVICES
 PROBATE
 TRAFFIC

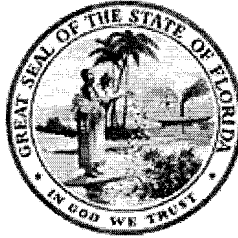

BRANCH OFFICES
ARCHIVES AND RECORDS
JUVENILE DIVISION
CENTURY

CLERK TO THE BOARD OF
 COUNTY COMMISSIONERS
 OFFICIAL RECORDS
 COUNTY TREASURY
 AUDITOR

COUNTY OF ESCAMBIA
OFFICE OF THE
CLERK OF THE CIRCUIT COURT

Case # 2021 TD 003154
Redeemed Date 11/27/2023

Name LYNE PITMAN 301 N PINWOOD LN PENSACOLA, FL 32507

Clerk's Total = TAXDEED	\$510.72 \$5,471.93
Due Tax Collector = TAXDEED	\$5,035.41
Postage = TD2	\$36.05
ResearcherCopies = TD6	\$0.00
Release TDA Notice (Recording) = RECORD2	\$10.00
Release TDA Notice (Prep Fee) = TD4	\$7.00

• For Office Use Only

Date	Docket	Desc	Amount Owed	Amount Due	Payee Name
------	--------	------	-------------	------------	------------

FINANCIAL SUMMARY

No Information Available - See Dockets

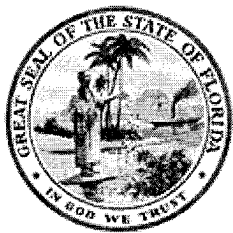

PAM CHILDERS
CLERK OF THE CIRCUIT COURT
ESCAMBIA COUNTY, FLORIDA

Tax Deed - Redemption Calculator
Account: 074448050 Certificate Number: 003154 of 2021

Redemption Yes
 Application Date
 Interest Rate

	Final Redemption Payment ESTIMATED	Redemption Overpayment ACTUAL
	Auction Date <input type="text" value="12/6/2023"/>	Redemption Date <input type="text" value="11/27/2023"/>
Months	8	7
Tax Collector	<input type="text" value="\$4,490.32"/>	<input type="text" value="\$4,490.32"/>
Tax Collector Interest	\$538.84	\$471.48
Tax Collector Fee	<input type="text" value="\$6.25"/>	<input type="text" value="\$6.25"/>
Total Tax Collector	\$5,035.41	<input type="text" value="\$4,968.05"/> <i>TC</i>
Record TDA Notice	<input type="text" value="\$17.00"/>	<input type="text" value="\$17.00"/>
Clerk Fee	<input type="text" value="\$119.00"/>	<input type="text" value="\$119.00"/>
Sheriff Fee	<input type="text" value="\$120.00"/>	<input type="text" value="\$120.00"/>
Legal Advertisement	<input type="text" value="\$200.00"/>	<input type="text" value="\$200.00"/>
App. Fee Interest	\$54.72	\$47.88
Total Clerk	\$510.72	<input type="text" value="\$503.88"/> <i>CH</i>
Release TDA Notice (Recording)	<input type="text" value="\$10.00"/>	<input type="text" value="\$10.00"/>
Release TDA Notice (Prep Fee)	<input type="text" value="\$7.00"/>	<input type="text" value="\$7.00"/>
Postage	<input type="text" value="\$36.05"/>	<input type="text" value="\$36.05"/>
Researcher Copies	<input type="text" value="\$0.00"/>	<input type="text" value="\$0.00"/>
Total Redemption Amount	\$5,599.18	\$5,524.98
	Repayment Overpayment Refund Amount	\$74.20

RELEASE OF NOTICE OF APPLICATION FOR TAX DEED

Pursuant to § 197.502(5)(c), Florida Statutes, the Escambia County Clerk of Court fully releases the Notice of Tax Deed Application recorded at Official Records Book 8975, Page 1845, of Escambia County, for the tax certificate, tax deed, and property described below:

Tax Certificate No. Certificate No. 03154, issued the 1st day of June, A.D., 2021

TAX ACCOUNT NUMBER: **074448050 (1223-29)**

DESCRIPTION OF PROPERTY:

**BEG AT INTER OF W LI OF 1ST ST AND N LI OF THIRD AVE NLY 360 FT FOR POB W 60 FT N TO
BAYOU ELY ALG BAYOU TO W LI OF 1ST ST SLY ALG 1ST ST 230 FT TO POB LT 1 BLK 17 OF
AN UNRECORDED PLAT OR 6314 P 867 CASE # 2006 CP 2295 CA 160**

SECTION 38, TOWNSHIP 2 S, RANGE 30 W

NAME IN WHICH ASSESSED: JERRY PITMAN TRUSTEE and ELMER W PITMAN JR TRUST

Dated this 27th day of November 2023.

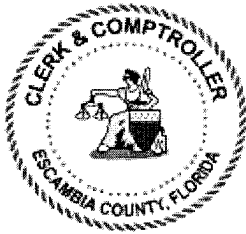

PAM CHILDERS
CLERK OF THE CIRCUIT COURT
ESCAMBIA COUNTY, FLORIDA

By:
Emily Hogg
Deputy Clerk

THE SUMMATION WEEKLY

A Weekly Publication of the Escambia-Santa Rosa Bar Association Since 2014

NOTICE OF APPLICATION FOR TAX DEED

NOTICE IS HEREBY GIVEN, That MIKON FINANCIAL SERVICES INC AND OCEAN BANK holder of Tax Certificate No. 03154, issued the 1st day of June, A.D., 2021 has filed same in my office and has made application for a tax deed to be issued thereon. Said certificate embraces the following described property in the County of Escambia, State of Florida, to wit:

BEG AT INTER OF W LI OF 1ST ST AND N LI OF THIRD AVE NLY 360 FT FOR POB W 60 FT N TO BAYOU ELY ALG BAYOU TO W LI OF 1ST ST SLY ALG 1ST ST 230 FT TO POB LT 1 BLK 17 OF AN UNRECORDED PLAT OR 6314 P 867 CASE # 2006 CP 2295 CA 160

SECTION 38, TOWNSHIP 2 S., RANGE 30 W TAX ACCOUNT NUMBER 07444R050 (1223-29)

The assessment of the said property under the said certificate issued was in the name of

JERRY PITMAN TRUSTEE and ELMER W PITMAN JR TRUST

Unless said certificate shall be redeemed according to law, the property described therein will be sold to the highest bidder at public auction at 9:00 A.M. on the first Wednesday in the month of December, which is the 6th day of December 2023.

Dated this 19th day of October 2023.

In accordance with the AMERICANS WITH DISABILITIES ACT, if you are a person with a disability who needs special accommodation in order to participate in this proceeding you are entitled to the provision of certain assistance. Please contact Emily Hogg not later than seven days prior to the proceeding at Escambia County Government Complex, 221 Palafox Place Ste 110, Pensacola FL 32502. Telephone: 850-595-3793.

PAM CHILDERS
CLERK OF THE CIRCUIT COURT
ESCAMBIA COUNTY, FLORIDA

By:
Emily Hogg
Deputy Clerk

4WR11/1-11/22TD

Before the undersigned authority personally appeared Malcolm Ballinger who under oath says that he is the Legal Administrator and Publisher of The Summation Weekly Newspaper published at Pensacola in Escambia & Santa Rosa County, Florida; that the attached copy of the advertisement, being a notice in the matter of 2021-TD-03154 in the Escambia County Court was published in said newspaper in and was printed and released on November 1, 2023; November 8, 2023; November 15, 2023; and November 22, 2023.

Affiant further says that the said Summation Weekly is a newspaper published at Pensacola, in said Escambia & Santa Rosa Counties, Florida, and that the said newspaper has heretofore been continuously published in said Escambia & Santa Rosa Counties, Florida each week and has been entered as second class mail matter at the post office in Pensacola, in said Escambia County, Florida, for a period of one year next preceding the first publication of the attached copy of advertisement; and affiant further says that he has neither paid nor promised any person, firm or corporation any discount, rebate, commission or refund for the purpose of securing this advertisement for publication of the said newspaper.

X 

MALCOLM BALLINGER, PUBLISHER FOR THE
SUMMATION WEEKLY

STATE OF FLORIDA
COUNTY OF ESCAMBIA

The foregoing instrument was acknowledged before me by means of physical presence or online notarization, this 22nd day of November, 2023, by MALCOLM BALLINGER, who is personally known to me.

X

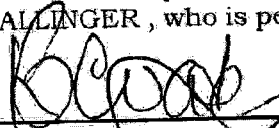
NOTARY PUBLIC
Brooklyn Faith Coates
Notary Public
State of Florida
Comm# HH053675
Expires 10/14/2024

