

CERTIFICATION OF TAX DEED APPLICATION

Sections 197.502 and 197.542, Florida Statutes

0621-52

513
R. 07/19

Part 1: Tax Deed Application Information					
Applicant Name Applicant Address	PLEASANT VALLEY CAPITAL LLC - 18 US BANK % PLEASANT VALLEY CAPITAL LLC - 18 PO BOX 645040 CINCINNATI, OH 45264-5040			Application date	Apr 21, 2020
Property description	MILLENDER KEITH SIMMONS SHAMETHA 1525 S FAIRFIELD DR PENSACOLA, FL 32507 1525 S FAIRFIELD DR LTS 13 14 BLK 45 BEACH HAVEN PLAT DB 46 P 51 OR 7660 P 414 SEC 54/35 T 2S R 30/31			Certificate #	2018 / 5321
				Date certificate issued	06/01/2018
				Deed application number	2000498
				Account number	10-0325-000
Part 2: Certificates Owned by Applicant and Filed with Tax Deed Application					
Column 1 Certificate Number	Column 2 Date of Certificate Sale	Column 3 Face Amount of Certificate	Column 4 Interest	Column 5: Total (Column 3 + Column 4)	
# 2018/5321	06/01/2018	1,042.68	52.13	1,094.81	
→Part 2: Total*				1,094.81	
Part 3: Other Certificates Redeemed by Applicant (Other than County)					
Column 1 Certificate Number	Column 2 Date of Other Certificate Sale	Column 3 Face Amount of Other Certificate	Column 4 Tax Collector's Fee	Column 5 Interest	Total (Column 3 + Column 4 + Column 5)
# 2019/5119	06/01/2019	745.40	6.25	37.27	788.92
Part 3: Total*					788.92
Part 4: Tax Collector Certified Amounts (Lines 1-7)					
1. Cost of all certificates in applicant's possession and other certificates redeemed by applicant (*Total of Parts 2 + 3 above)					1,883.73
2. Delinquent taxes paid by the applicant					0.00
3. Current taxes paid by the applicant					343.32
4. Property information report fee and Deed Application Recording and Release Fees					200.00
5. Tax deed application fee					175.00
6. Interest accrued by tax collector under s.197.542, F.S. (see Tax Collector Instructions, page 2)					0.00
7. Total Paid (Lines 1-6)					2,602.05
I certify the above information is true and the tax certificates, interest, property information report fee, and tax collector's fees have been paid, and that the property information statement is attached.					
Sign here: _____			Escambia County, Florida		
Signature, Tax Collector or Designee			Date <u>May 7th, 2020</u>		

Send this certification to the Clerk of Court by 10 days after the date signed. See Instructions on Page 2

Part 5: Clerk of Court Certified Amounts (Lines 8-14)	
8. Processing tax deed fee	
9. Certified or registered mail charge	
10. Clerk of Court advertising, notice for newspaper, and electronic auction fees	
11. Recording fee for certificate of notice	
12. Sheriff's fees	
13. Interest (see Clerk of Court Instructions, page 2)	
14. Total Paid (Lines 8-13)	
15. Plus one-half of the assessed value of homestead property, if applicable under s. 197.502(6)(c), F.S.	20070.50
16. Other outstanding certificates and delinquent taxes not included in this Application, if applicable per Florida statutes	
17. Statutory opening bid (total of Lines 7, 14, 15, and 16 if applicable)	
18. Redemption fee	6.25
19. Total amount to redeem	
Sign here: _____ Date of sale <u>06/07/2021</u>	
Signature, Clerk of Court or Designee	

INSTRUCTIONS

Tax Collector (complete Parts 1-4)

Part 2: Certificates Owned by Applicant and Filed with Tax Deed Application

Enter the Face Amount of Certificate in Column 3 and the Interest in Column 4 for each certificate number. Add Columns 3 and 4 and enter the amount in Column 5.

Part 3: Other Certificates Redeemed by Applicant (Other than County)

Total. Add the amounts in Columns 3, 4 and 5

Part 4: Tax Collector Certified Amounts (Lines 1-7)

Line 1, enter the total of Part 2 plus the total of Part 3 above.

Total Paid, Line 7: Add the amounts of Lines 1-6

Line 6, Interest accrued by tax collector. Calculate the 1.5 percent interest accrued from the month after the date of application through the month this form is certified to the clerk. Enter the amount to be certified to the clerk on **Line 6**. The interest calculated by the tax collector stops before the interest calculated by the clerk begins. See Section 197.542, F.S., and Rule 12D-13.060(3), Florida Administrative Code.

The tax collector's interest for redemption at the time of the tax deed application is a cost of redemption, which encompasses various percentages of interest on certificates and omitted or delinquent taxes under Section 197.502, F.S. This interest is calculated before the tax collector calculates the interest in Section 197.542, F.S.

Attach certified statement of names and addresses of persons who must be notified before the sale of the property. Send this form and any required attachments to the Clerk of Court within 10 days after it is signed.

Clerk of Court (complete Part 5)

Line 13: Interest is calculated at the rate of 1.5 percent per month starting from the first day of the month after the month of certification of this form through the last day of the month in which the sale will be held. Multiply the calculated rate by the total of **Line 7**, minus **Line 6**, plus **Lines 8** through **12**. Enter the amount on **Line 13**.

Line 14: Enter the total of Lines 8-13. Complete Lines 15-18, if applicable.

APPLICATION FOR TAX DEED

Section 197.502, Florida Statutes

512
R. 12/16

Application Number: 2000498

To: Tax Collector of ESCAMBIA COUNTY, Florida

I,

PLEASANT VALLEY CAPITAL LLC - 18
US BANK % PLEASANT VALLEY CAPITAL LLC - 18
PO BOX 645040
CINCINNATI, OH 45264-5040,

hold the listed tax certificate and hereby surrender the same to the Tax Collector and make tax deed application thereon:

Account Number	Certificate No.	Date	Legal Description
10-0325-000	2018/5321	06-01-2018	LTS 13 14 BLK 45 BEACH HAVEN PLAT DB 46 P 51 OR 7660 P 414 SEC 54/35 T 2S R 30/31

I agree to:

- pay any current taxes, if due and
- redeem all outstanding tax certificates plus interest not in my possession, and
- pay all delinquent and omitted taxes, plus interest covering the property.
- pay all Tax Collector's fees, property information report costs, Clerk of the Court costs, charges and fees, and Sheriff's costs, if applicable.

Attached is the tax sale certificate on which this application is based and all other certificates of the same legal description which are in my possession.

Electronic signature on file
PLEASANT VALLEY CAPITAL LLC - 18
US BANK % PLEASANT VALLEY CAPITAL LLC - 18
PO BOX 645040
CINCINNATI, OH 45264-5040

04-21-2020
Application Date

Applicant's signature



Chris Jones Escambia County Property Appraiser

Real Estate Search

Tangible Property Search

Sale List

[Back](#)

◀ [Navigate Mode](#) [Account](#) [Reference](#) ▶

[Printer Friendly Version](#)

General Information	
Reference:	352S311000013045
Account:	100325000
Owners:	MILLENDER KEITH SIMMONS SHAMETHA
Mail:	1525 S FAIRFIELD DR PENSACOLA, FL 32507
Situs:	1525 S FAIRFIELD DR 32507
Use Code:	SINGLE FAMILY RESID
Taxing Authority:	COUNTY MSTU
Tax Inquiry:	Open Tax Inquiry Window
Tax Inquiry link courtesy of Scott Lunsford Escambia County Tax Collector	

Assessments				
Year	Land	Imprv	Total	Cap Val
2019	\$12,800	\$27,341	\$40,141	\$40,141
2018	\$12,160	\$25,406	\$37,566	\$37,566
2017	\$12,160	\$43,511	\$55,671	\$55,671

Disclaimer

Tax Estimator

> File for New Homestead Exemption Online

Sales Data					
Sale Date	Book	Page	Value	Type	Official Records (New Window)
03/27/2017	8076	707	\$100	WD	View Instr
01/19/2017	7660	414	\$100	WD	View Instr
01/03/2017	7660	411	\$103,900	WD	View Instr
07/2005	5697	294	\$79,900	WD	View Instr
03/2005	5614	663	\$100	CT	View Instr
04/2000	4590	1727	\$100	QC	View Instr
04/2000	4552	648	\$100	QC	View Instr
Official Records Inquiry courtesy of Pam Childers Escambia County Clerk of the Circuit Court and Comptroller					

2019 Certified Roll Exemptions
HOMESTEAD EXEMPTION

Legal Description
LTS 13 14 BLK 45 BEACH HAVEN PLAT DB 46 P 51 OR
8076 P 707 SEC 54/35 T 2S R 30/31

Extra Features
FRAME BUILDING

Parcel Information

[Launch Interactive Map](#)

Section Map Id:
35-2S-31-2

Approx. Acreage:
0.3376

Zoned:
Com

Evacuation & Flood Information
[Open Report](#)

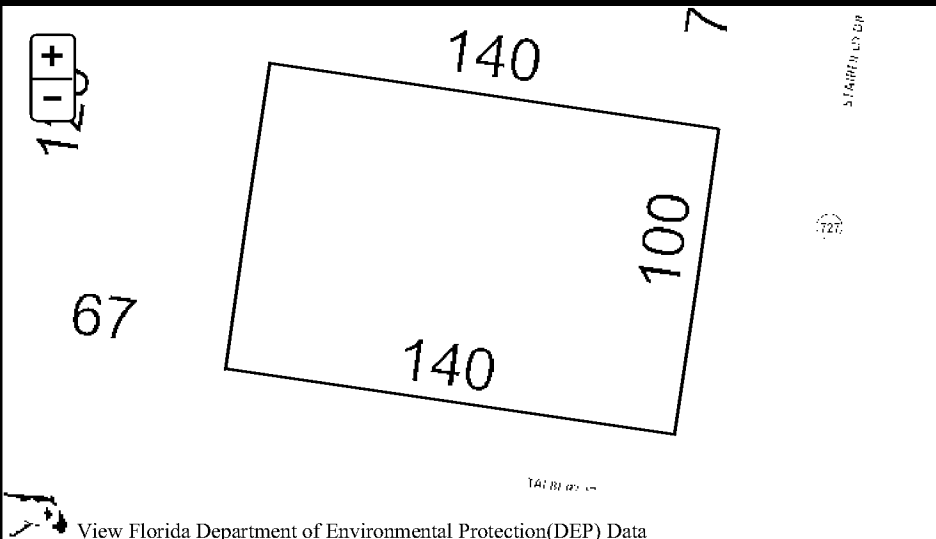

[View Florida Department of Environmental Protection\(DEP\) Data](#)

Buildings

Address: 1525 S FAIRFIELD DR, Year Built: 1959, Effective Year: 1959	
Structural Elements	
DECOR/MILLWORK-AVERAGE	

DWELLING UNITS-1
EXTERIOR WALL-ALUMINUM SIDING
FLOOR COVER-CARPET
FOUNDATION-WOOD/NO SUB FLR
HEAT/AIR-CENTRAL H/AC
INTERIOR WALL-DRYWALL-PLASTER
NO. PLUMBING FIXTURES-3
NO. STORIES-1
ROOF COVER-COMPOSITION SHG
ROOF FRAMING-GABLE
STORY HEIGHT-0
STRUCTURAL FRAME-WOOD FRAME

 Areas - 2182 Total SF

BASE AREA - 1064
BASE SEMI FIN - 264
CARPORT UNF - 506
OPEN PORCH FIN - 204
UTILITY UNF - 144

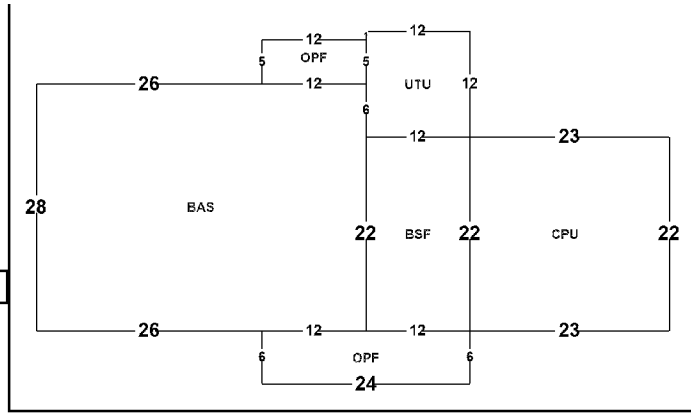

Images



2/4/20

The primary use of the assessment data is for the preparation of the current year tax roll. No responsibility or liability is assumed for inaccuracies or errors.

NOTICE OF APPLICATION FOR TAX DEED

NOTICE IS HEREBY GIVEN, That **PLEASANT VALLEY CAPITAL LLC - 18 US BANK** holder of **Tax Certificate No. 05321**, issued the **1st day of June, A.D., 2018** has filed same in my office and has made application for a tax deed to be issued thereon. Said certificate embraces the following described property in the County of Escambia, State of Florida, to wit:

LTS 13 14 BLK 45 BEACH HAVEN PLAT DB 46 P 51 OR 8076 P 707 SEC 54/35 T 2S R 30/31

SECTION 35, TOWNSHIP 2 S, RANGE 31 W

TAX ACCOUNT NUMBER 100325000 (0621-52)

The assessment of the said property under the said certificate issued was in the name of

KEITH MILLENDER and SHAMETHA SIMMONS

Unless said certificate shall be redeemed according to law, the property described therein will be sold to the highest bidder at public auction at 9:00 A.M. on the **first Monday** in the month of **June**, which is the **7th day of June 2021**.

Dated this 15th day of June 2020.

In accordance with the AMERICANS WITH DISABILITIES ACT, if you are a person with a disability who needs special accommodation in order to participate in this proceeding you are entitled to the provision of certain assistance. Please contact Emily Hogg not later than seven days prior to the proceeding at Escambia County Government Complex, 221 Palafox Place Ste 110, Pensacola FL 32502. Telephone: 850-595-3793.

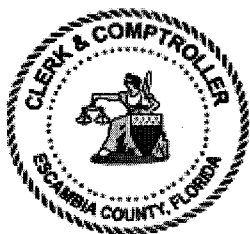

PAM CHILDERS
CLERK OF THE CIRCUIT COURT
ESCAMBIA COUNTY, FLORIDA

By:
Emily Hogg
Deputy Clerk

RELEASE OF NOTICE OF APPLICATION FOR TAX DEED

Pursuant to § 197.502(5)(c), Florida Statutes, the Escambia County Clerk of Court fully releases the Notice of Tax Deed Application recorded at Official Records Book 8313, Page 507, of Escambia County, for the tax certificate, tax deed, and property described below:

Tax Certificate No. Certificate No. 05321, issued the 1st day of June, A.D., 2018

TAX ACCOUNT NUMBER: 100325000 (0621-52)

DESCRIPTION OF PROPERTY:

LTS 13 14 BLK 45 BEACH HAVEN PLAT DB 46 P 51 OR 8076 P 707 SEC 54/35 T 2S R 30/31

SECTION 35, TOWNSHIP 2 S, RANGE 31 W

NAME IN WHICH ASSESSED: KEITH MILLENDER and SHAMETHA SIMMONS

Dated this 16th day of June 2020.



PAM CHILDERS
CLERK OF THE CIRCUIT COURT
ESCAMBIA COUNTY, FLORIDA

By:
Emily Hogg
Deputy Clerk



PAM CHILDERS
CLERK OF THE CIRCUIT COURT
ESCAMBIA COUNTY, FLORIDA

Tax Deed - Redemption Calculator

Account: 100325000 Certificate Number: 005321 of 2018

Redemption	<input type="text" value="No"/>	Application Date	<input type="text" value="04/21/2020"/>	Interest Rate	<input type="text" value="18%"/>
		Final Redemption Payment ESTIMATED		Redemption Overpayment ACTUAL	
		Auction Date	<input type="text" value="06/07/2021"/>	Redemption Date	<input type="text" value="06/16/2020"/>
Months		14		2	
Tax Collector		<input type="text" value="\$2,602.05"/>		<input type="text" value="\$2,602.05"/>	
Tax Collector Interest		\$546.43		\$78.06	
Tax Collector Fee		<input type="text" value="\$6.25"/>		<input type="text" value="\$6.25"/>	
Total Tax Collector		\$3,154.73		\$2,686.36	T.C.
Record TDA Notice		<input type="text" value="\$17.00"/>		<input type="text" value="\$17.00"/>	
Clerk Fee		<input type="text" value="\$130.00"/>		<input type="text" value="\$130.00"/>	
Sheriff Fee		<input type="text" value="\$120.00"/>		<input type="text" value="\$120.00"/>	-
Legal Advertisement		<input type="text" value="\$200.00"/>		<input type="text" value="\$200.00"/>	-
App. Fee Interest		\$98.07		\$14.01	
Total Clerk		\$565.07		\$481.01	C.H.
Release TDA Notice (Recording)		<input type="text" value="\$10.00"/>		<input type="text" value="\$10.00"/>	
Release TDA Notice (Prep Fee)		<input type="text" value="\$7.00"/>		<input type="text" value="\$7.00"/>	
Postage		<input type="text" value="\$60.00"/>		<input type="text" value="\$0.00"/>	
Researcher Copies		<input type="text" value="\$40.00"/>		<input type="text" value="\$0.00"/>	
Total Redemption Amount		\$3,836.80		\$3,184.37 - 120 - 200	
		Repayment Overpayment Refund Amount		\$652.43	<u>\$2,864.37</u>
Book/Page		<input type="text" value="8313"/>		<input type="text" value="507"/>	

PAM CHILDERS
 CLERK OF THE CIRCUIT COURT
 ARCHIVES AND RECORDS
 CHILDSUPPORT
 CIRCUIT CIVIL
 CIRCUIT CRIMINAL
 COUNTY CIVIL
 COUNTY CRIMINAL
 DOMESTIC RELATIONS
 FAMILY LAW
 JURY ASSEMBLY
 JUVENILE
 MENTAL HEALTH
 MIS
 OPERATIONAL SERVICES
 PROBATE
 TRAFFIC

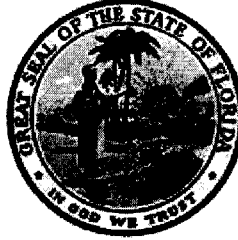

**COUNTY OF ESCAMBIA
 OFFICE OF THE
 CLERK OF THE CIRCUIT COURT**

**BRANCH OFFICES
 ARCHIVES AND RECORDS
 JUVENILE DIVISION
 CENTURY**

CLERK TO THE BOARD OF
 COUNTY COMMISSIONERS
 OFFICIAL RECORDS
 COUNTY TREASURY
 AUDITOR

**PAM CHILDERS, CLERK OF THE CIRCUIT COURT
 Tax Certificate Redeemed From Sale
 Account: 100325000 Certificate Number: 005321 of 2018**

**Payor: SHAMETHA SIMMONS 1525 S FAIRFIELD DR PENSACOLA, FL 32507 Date
 06/16/2020**

Clerk's Check # 1
 Tax Collector Check # 1

Clerk's Total	\$565.07	\$2,847.37
Tax Collector's Total	\$3,764.73	
Postage	\$60.00	
Researcher Copies	\$0.00	
Recording	\$10.00	
Prep Fee	\$7.00	
Total Received	\$3,796.80	\$2,864.37

**PAM CHILDERS
 Clerk of the Circuit Court**

Received By: *Whitney Copping*
 Deputy Clerk

PAM CHILDERS
 CLERK OF THE CIRCUIT COURT
 ARCHIVES AND RECORDS
 CHILDSUPPORT
 CIRCUIT CIVIL
 CIRCUIT CRIMINAL
 COUNTY CIVIL
 COUNTY CRIMINAL
 DOMESTIC RELATIONS
 FAMILY LAW
 JURY ASSEMBLY
 JUVENILE
 MENTAL HEALTH
 MIS
 OPERATIONAL SERVICES
 PROBATE
 TRAFFIC

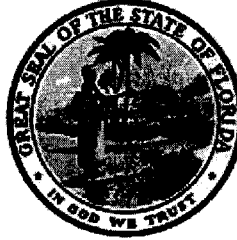

**COUNTY OF ESCAMBIA
 OFFICE OF THE
 CLERK OF THE CIRCUIT COURT**

**BRANCH OFFICES
 ARCHIVES AND RECORDS
 JUVENILE DIVISION
 CENTURY**

CLERK TO THE BOARD OF
 COUNTY COMMISSIONERS
 OFFICIAL RECORDS
 COUNTY TREASURY
 AUDITOR

**Case # 2018 TD 005321
 Redeemed Date 06/16/2020**

Name SHAMETHA SIMMONS 1525 S FAIRFIELD DR PENSACOLA, FL 32507

Clerk's Total = TAXDEED	\$565.07	
Due Tax Collector = TAXDEED	\$3,154.73	\$2,847.37
Postage = TD2	\$60.00	
ResearcherCopies = TD6	\$0.00	
Release TDA Notice (Recording) = RECORD2	\$10.00	
Release TDA Notice (Prep Fee) = TD4	\$7.00	

• For Office Use Only

Date	Docket	Desc	Amount Owed	Amount Due	Payee Name
------	--------	------	-------------	------------	------------

FINANCIAL SUMMARY

No Information Available - See Dockets



CERTIFICATION OF TAX DEED APPLICATION

Sections 197.502 and 197.542, Florida Statutes

DR-513
Rule 12D-16.002 F.A.C
Effective 07/19
Page 1 of 2

Part 1: Tax Deed Application Information					
Applicant Name Applicant Address	PLEASANT VALLEY CAPITAL LLC - 18 US BANK % PLEASANT VALLEY CAPITAL LLC - 18 PO BOX 645040 CINCINNATI, OH 45264-5040	Application date	Apr 21, 2020		
Property description	MILLENDER KEITH SIMMONS SHAMETHA 1525 S FAIRFIELD DR PENSACOLA, FL 32507 1525 S FAIRFIELD DR 10-0325-000 LTS 13 14 BLK 45 BEACH HAVEN PLAT DB 46 P 51 OR 7660 P 414 SEC 54/35 T 2S R 30/31	Certificate #	2018 / 5321		
		Date certificate issued	06/01/2018		
Part 2: Certificates Owned by Applicant and Filed with Tax Deed Application					
Column 1 Certificate Number	Column 2 Date of Certificate Sale	Column 3 Face Amount of Certificate	Column 4 Interest	Column 5: Total (Column 3 + Column 4)	
# 2018/5321	06/01/2018	1,042.68	52.13	1,094.81	
→Part 2: Total*				1,094.81	
Part 3: Other Certificates Redeemed by Applicant (Other than County)					
Column 1 Certificate Number	Column 2 Date of Other Certificate Sale	Column 3 Face Amount of Other Certificate	Column 4 Tax Collector's Fee	Column 5 Interest	Total (Column 3 + Column 4 + Column 5)
# 2019/5119	06/01/2019	745.40	6.25	37.27	788.92
Part 3: Total*					788.92
Part 4: Tax Collector Certified Amounts (Lines 1-7)					
1. Cost of all certificates in applicant's possession and other certificates redeemed by applicant (<i>*Total of Parts 2 + 3 above</i>)					1,883.73
2. Delinquent taxes paid by the applicant					0.00
3. Current taxes paid by the applicant					343.32
4. Property information report fee					200.00
5. Tax deed application fee					175.00
6. Interest accrued by tax collector under s.197.542, F.S. (see Tax Collector Instructions, page 2)					0.00
7. Total Paid (Lines 1-6)					2,602.05
I certify the above information is true and the tax certificates, interest, property information report fee, and tax collector's fees have been paid, and that the property information statement is attached.					
Sign here:	 Signature, Tax Collector or Designee				Date <u>August 26th, 2020</u>
<i>Send this certification to the Clerk of Court by 10 days after the date signed. See Instructions on Page 2</i>					

Part 5: Clerk of Court Certified Amounts (Lines 8-14)	
8. Processing tax deed fee	
9. Certified or registered mail charge	
10. Clerk of Court advertising, notice for newspaper, and electronic auction fees	
11. Recording fee for certificate of notice	
12. Sheriff's fees	
13. Interest (see Clerk of Court Instructions, page 2)	
14. Total Paid (Lines 8-13)	
15. Plus one-half of the assessed value of homestead property, if applicable under s. 197.502(6)(c), F.S.	20,070.50
16. Statutory opening bid (total of Lines 7, 14, 15, and 16 if applicable)	
Sign here: _____ Date of sale <u>06/07/2021</u> Signature, Clerk of Court or Designee	

INSTRUCTIONS + 6.25

Tax Collector (complete Parts 1-4)

Part 2: Certificates Owned by Applicant and Filed with Tax Deed Application

Enter the Face Amount of Certificate in Column 3 and the Interest in Column 4 for each certificate number. Add Columns 3 and 4 and enter the amount in Column 5.

Part 3: Other Certificates Redeemed by Applicant (Other than County)

Total. Add the amounts in Columns 3, 4 and 5

Part 4: Tax Collector Certified Amounts (Lines 1-7)

Line 1, enter the total of Part 2 plus the total of Part 3 above.

Total Paid, Line 7: Add the amounts of Lines 1-6

Line 6, Interest accrued by tax collector. Calculate the 1.5 percent interest accrued from the month after the date of application through the month this form is certified to the clerk. Enter the amount to be certified to the clerk on **Line 6**. The interest calculated by the tax collector stops before the interest calculated by the clerk begins. See Section 197.542, F.S., and Rule 12D-13.060(3), Florida Administrative Code.

The tax collector's interest for redemption at the time of the tax deed application is a cost of redemption, which encompasses various percentages of interest on certificates and omitted or delinquent taxes under Section 197.502, F.S. This interest is calculated before the tax collector calculates the interest in Section 197.542, F.S.

Attach certified statement of names and addresses of persons who must be notified before the sale of the property. Send this form and any required attachments to the Clerk of Court within 10 days after it is signed.

Clerk of Court (complete Part 5)

Line 13: Interest is calculated at the rate of 1.5 percent per month starting from the first day of the month after the month of certification of this form through the last day of the month in which the sale will be held. Multiply the calculated rate by the total of **Line 7**, minus **Line 6**, plus **Lines 8** through **12**. Enter the amount on **Line 13**.

Line 14: Enter the total of Lines 8-13. Complete Lines 15-18, if applicable.



PROPERTY INFORMATION REPORT
3050 Concho Drive, Pensacola, Florida 32507 | Phone: 850-466-3077

THE ATTACHED REPORT IS ISSUED TO:

SCOTT LUNSFORD, ESCAMBIA COUNTY TAX COLLECTOR

TAX ACCOUNT #: 10-0325-000 CERTIFICATE #: 2018-5321

THIS REPORT IS NOT TITLE INSURANCE. THE LIABILITY FOR ERRORS OR OMISSIONS IN THIS REPORT IS LIMITED TO THE PERSON(S) EXPRESSLY IDENTIFIED BY NAME IN THE PROPERTY INFORMATION REPORT AS THE RECIPIENT(S) OF THE PROPERTY INFORMATION REPORT.

The attached Report prepared in accordance with the instructions given by the user named above includes a listing of the owner(s) of record of the land described herein together with current and delinquent ad valorem tax information and a listing and copies of all open or unsatisfied leases, mortgages, judgments and encumbrances recorded in the Official Record Books of Escambia County, Florida that appear to encumber the title to said land as listed on page 2 herein. It is the responsibility of the party named above to verify receipt of each document listed. If a copy of any document listed is not received, the office issuing this Report must be contacted immediately.

This Report is subject to: Current year taxes; taxes and assessments due now or in subsequent years; oil, gas, and mineral or any subsurface rights of any kind or nature; easements, restrictions and covenants of record; encroachments, overlaps, boundary line disputes, and any other matters that would be disclosed by an accurate survey and inspection of the premises.

This Report does not insure or guarantee the validity or sufficiency of any document attached, nor is it to be considered a title insurance policy, an opinion of title, a guarantee of title, or as any other form of guarantee or warranty of title.

Use of the term "Report" herein refers to the Property Information Report and the documents attached hereto.

Period Searched: October 10, 1996 to and including March 22, 2021 Abstractor: LaChelle Floyd

BY

A handwritten signature in black ink, appearing to read "Michael A. Campbell", written over a horizontal line.

Michael A. Campbell,
As President
Dated: March 29, 2021

PROPERTY INFORMATION REPORT
CONTINUATION PAGE

March 29, 2021

Tax Account #: 10-0325-000

1. The Grantee(s) of the last deed(s) of record is/are: **SHAMETHA SIMMONS AND KEITH MILLENDER, as joint tenant with full right of survivorship**
- 2.
3. **By Virtue of Warranty Deed recorded 04/10/2019 – OR 8076/707 (ABTRACTOR’S NOTE: We found a Marriage license recorded for Keith Millender and Shametha Simmons married after the execution of this Warranty Deed recorded 06/06/2019 so we have included her under both last names for notice)**

4. The land covered by this Report is: **See Attached Exhibit “A”**

5. The following unsatisfied mortgages, liens, and judgments affecting the land covered by this Report appear of record:
 - a. **Judgment in favor of State of Florida recorded 06/15/2007 – OR 6164/617**
 - b. **Judgment in favor of State of Florida recorded 05/29/2018 – OR 7907/1402**

6. Taxes:

Taxes for the year(s) 2017-2019 are delinquent.
Tax Account #: 10-0325-000
Assessed Value: \$41,064
Exemptions: HOMESTEAD

7. We find the following HOA names in our search (if a condominium, the condo docs book and page are included for your review): **NONE**

Payment of any special liens/assessments imposed by City, County, and/or State.

Note: Escambia County and/or local municipalities may impose special liens/assessments. These liens/assessments are not discovered in a title search or shown above. These special assessments typically create a lien on real property. The entity that governs subject property must be contacted to verify payment status.

PERDIDO TITLE & ABSTRACT, INC.
PROPERTY INFORMATION REPORT
3050 Concho Drive, Pensacola, Florida 32507 | Phone 850-466-3077

Scott Lunsford
Escambia County Tax Collector
P.O. Box 1312
Pensacola, FL 32591

CERTIFICATION: TITLE SEARCH FOR TDA

TAX DEED SALE DATE: June 7, 2021

TAX ACCOUNT #: 10-0325-000

CERTIFICATE #: 2018-5321

In compliance with Section 197.522, Florida Statutes, the following is a list of names and addresses of those persons, firms, and/or agencies having legal interest in or claim against the above-described property. The above-referenced tax sale certificate is being submitted as proper notification of tax deed sale.

YES NO

 X Notify City of Pensacola, P.O. Box 12910, 32521
X Notify Escambia County, 190 Governmental Center, 32502
X Homestead for 2020 tax year.

**KEITH MILLENDER AND
SHAMETHA SIMMONS
AKA SHAMETHA MILLENDER
1525 S. FAIRFIELD DR
PENSACOLA, FL 32507**

**SHAMETHA SHARELL SIMMONS
700 TRUMAN AV 205
PENSACOLA, FL 32505**

Certified and delivered to Escambia County Tax Collector, this 29th day of March, 2021.

PERDIDO TITLE & ABSTRACT, INC.



BY: Michael A. Campbell, As It's President

NOTE: The above listed addresses are based upon current information available, but addresses are not guaranteed to be true or correct.

PROPERTY INFORMATION REPORT

March 29, 2021

Tax Account #: 10-0325-000

**LEGAL DESCRIPTION
EXHIBIT "A"**

LTS 13 14 BLK 45 BEACH HAVEN PLAT DB 46 P 51 OR 8076 P 707 SEC 54/35 T 2S R 30/31

SECTION 35, TOWNSHIP 2 S, RANGE 31 W

TAX ACCOUNT NUMBER 10-0325-000 (0621-52)

PLEASE COMPLETE THIS INFORMATION

RECORDING REQUESTED BY:

Erica White

500 North Broadway

St. Louis, MO 63102

AND WHEN RECORDED MAIL TO:

Stewart Title Guaranty Company

Attn: Recording

500 North Broadway

St. Louis, MO 63102

THIS SPACE FOR RECORDERS USE ONLY

Deed

Re recording Deed in the correct County of Escambia. Previous deed recorded 3/28/2017 as
BK: 17925 PG: 316 in the public records of DUVAL County. All fees paid with previous recording.

Prepared by & Return to:
Stewart Lender Services
Closer: ARIEL MULLINS
2002 N. Lois Ave., Suite 700
Tampa, FL 33607
as a necessary incident to the fulfillment of conditions
contained in a title insurance commitment issued by it.

Property Appraisers Parcel I.D. (Folio) Number(s):
352S311000013045

**SPECIAL WARRANTY DEED
(CORPORATE)**

This Special Warranty Deed Made the 27th day of March, 2017, by Fannie Mae a/k/a Federal National Mortgage Association, and having its place of business at P.O. Box 650043 Dallas, TX 75265-0043, hereinafter called the grantor, to SHAMETHA SIMMONS, a single person, AND KEITH MILLENDER, a single person, as joint tenant with full rights of survivorship, whose post office address is: 1525 S FAIRFEILD DR, PENSACOLA, FL 32507 hereinafter called the grantee,

WITNESSETH: That grantor, for and in consideration of the sum of \$37,000.00 Dollars and other valuable considerations, receipt whereof is hereby acknowledged, by these presents does grant, bargain, sell, alien, remise, release, convey and confirm unto the grantee, all that certain land situate in ESCAMBIA County, Florida, viz:

Lots 13 and 14, Block 45, Beach Haven Subdivision, being a Portion of Section 35 South, Township 2 South, Range 31 West, according to the Plat thereof, as recorded in Deed Book 46, at Page 51, of the Public Records of Escambia County, Florida.

TOGETHER with all the tenements, hereditaments and appurtenances thereto belonging or in anywise appertaining.

SUBJECT ALSO to taxes and assessments for the year 2016 and subsequent years.

To Have and to Hold, the same in fee simple forever.

GRANTOR'S WILL WARRANT and forever defend the right and title to the above-described real property unto the Grantees against the claims of all person, claiming by, through or under Grantor's, but not otherwise.

(Wherever used herein the terms "grantor" and "grantee" included all the parties to this instrument, and the heirs, legal representatives and assigns of individuals, and the successors and assigns of corporation.)

IN WITNESS WHEREOF, Grantor has caused these presents to be executed in its name, and its corporate seal to be hereunto affixed, by its proper officers thereunto duly authorized, the day and year first above written.

SIGNED IN THE PRESENCE OF THE FOLLOWING WITNESSES
(TWO SEPARATE DISINTERESTED WITNESSES REQUIRED)

Witness Signature: *Ariel Mollias*
Printed Name: **Ariel Mollias** Fannie Mae a/k/a Federal National Mortgage Association By Stewart Lender Services as Attorney in fact

Witness Signature: *Kevin Nims*
Printed Name: **Kevin Nims** BY: *Cliff Lounsbury*
Assistant Vice President **Cliff Lounsbury**

State of **Florida**
County of **Hillsborough**

The foregoing instrument was acknowledged before me this 27th day of March 2017 by Cliff Lounsbury Assistant Vice President of Stewart Lender Services, Inc., as Attorney in Fact for Fannie Mae a/k/a Federal National Mortgage Association. She/He is personally known to me.

My Commission expires: 1-1-18
Notary Public Signature: *Kevin Lee Nims*
Printed Name: **Kevin Nims**
Serial Number: _____

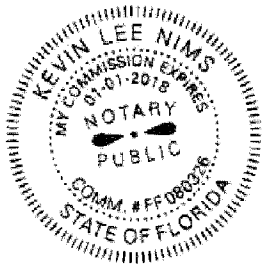

(SEAL)

IN THE COUNTY COURT IN AND
FOR ESCAMBIA COUNTY, FLORIDA

STATE OF FLORIDA,

vs.

CASE NO.: 2007 MM 021723 A
DIVISION: II

DEFENDANT: SHAMETHA SHARELL SIMMONS
700 TRUMAN AV 205
PENSACOLA, FL 32505

DATE OF BIRTH: 08/28/1970

ERNEE LEE MAGAHA
CLERK OF CIRCUIT COURT
ESCAMBIA COUNTY, FL
2007 JUN -7 P 3:11
COUNTY CRIMINAL DIVISION
FILED & RECORDED

FINAL JUDGMENT FOR FINES, COSTS, AND ADDITIONAL CHARGES

On MAY 7, 2007, an order assessing fines, costs, and additional charges was entered
against Defendant requiring payment of certain sums for fines, costs, and additional charges.

Defendant having failed to make full payment,

IT IS ADJUDGED that the Escambia County Clerk of Court, 190 Governmental Center,
Pensacola, Florida 32502 recover from Defendant those remaining unpaid fines, costs and
additional charges in the sum of \$ 600.00, the amount of which shall bear interest at the rate
prescribed by law (11%) until satisfied.

It is further ORDERED AND ADJUDGED that a lien is hereby created against all of the
property, both real and personal, of the defendant.

FOR WHICH LET EXECUTION ISSUE.

DONE AND ORDERED in open court/chambers in Pensacola, Escambia County,

Florida, this 30 day of May, 2007



COUNTY JUDGE

cc: ASSISTANT STATE ATTORNEY
cc: DEFENDANT

6/12/07

Case: 2007 MM 021723 A

00085073016
Dkt: MM191 Pg#:

Filing # 72389089 E-Filed 05/18/2018 05:06:03 PM

IN THE COUNTY COURT IN AND FOR ESCAMBIA COUNTY, FLORIDA

STATE OF FLORIDA,

Case No.: 2018 CT 001214

vs.

DIV: IV

KEITH LABARRON MILLENDER,
DEFENDANT

ORDER OF JUDGMENT AND SENTENCE

This cause, coming on this day to be heard before the Court, and the Defendant being now present without Counsel, having entered a Plea(s) as follows:

Guilty as to Count(s): _____

Not Guilty as to Count(s): _____

No Contest as to Count(s): 1

The State Attorney announced Nolle Prosequi as to Count(s): _____

A Jury of your peers having found you: _____.

The Court hereby:

Adjudicates Defendant Guilty as to Count(s): _____

Withholds Adjudication as to Count(s): 1

Finds Defendant Not Guilty as to Count(s): _____

Finds as to Count(s): _____

Count	Statute	Statute Description	Level	Degree
1	322.34(2a)	DRIVING WHILE LICENSE SUSPENDED FIRST CONVICTION	M	S

millender

STATE OF FLORIDA

V.

KEITH LABARRON MILLENDER

2018 CT 001214

DEFENDANT.

CASE NUMBERS

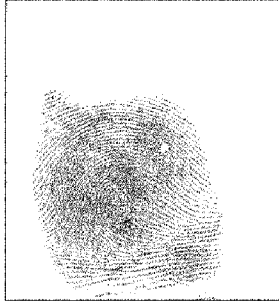
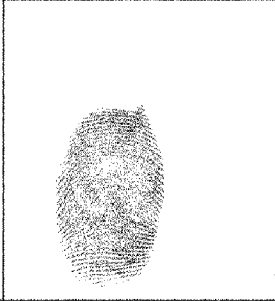
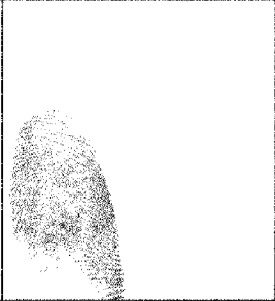
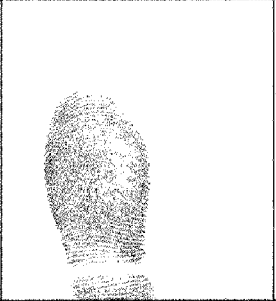
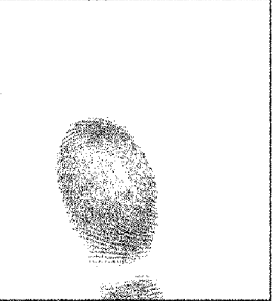
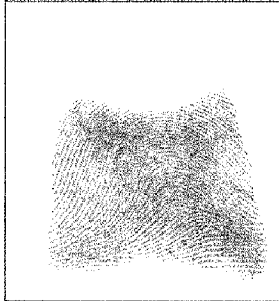
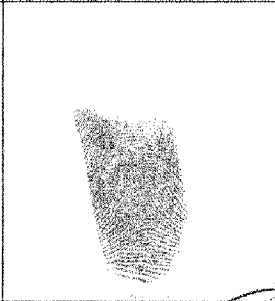
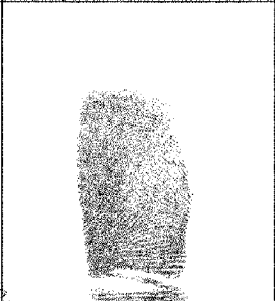
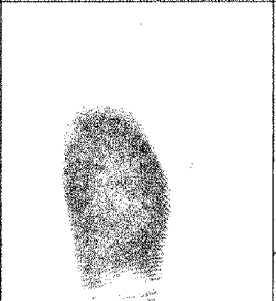
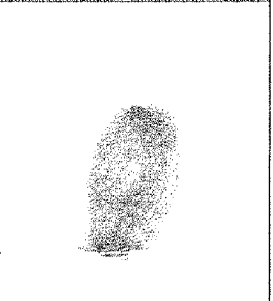
FINGERPRINTS OF DEFENDANT				
1. RIGHT THUMB	2. RIGHT INDEX	3. RIGHT MIDDLE	4. RIGHT RING	5. RIGHT LITTLE
				
1. LEFT THUMB	2. LEFT INDEX	3. LEFT MIDDLE	4. LEFT RING	5. LEFT LITTLE
				

FINGERPRINTS TAKEN BY:



NAME

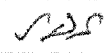

TITLE

I HEREBY CERTIFY that the above and foregoing are the fingerprints of the defendant,

KEITH LABARRON MILLENDER

and that they were placed thereon by the defendant in my presence in open court this date.

DONE AND ORDERED in open court in ESCAMBIA County, Florida, this

3RD day of APRIL

2018

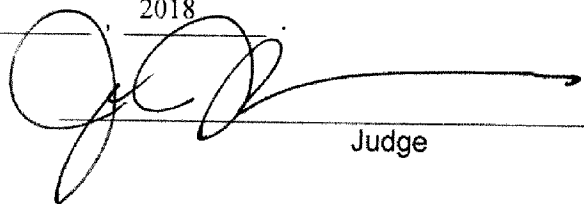

Judge

Under Authority granted to the Court by Florida law, it is ORDERED and ADJUDGED that:

As to COUNT 1, the Defendant is sentenced as follows:

As to the Contempt:

- The Court takes no action
- The Court finds the Defendant Guilty Withheld and sentences as follows:

JAIL:

- _____ Months, _____ Days County Jail as follows:
 - Credit for time served: _____ Days
 - _____ days County Jail Suspended
 - Work Release **Authorized**
 - Serve time beginning immediately
 - Report to Court on _____, at _____ to begin your sentence

- Time to be Consecutive Concurrent with Count _____
- Time Served
- Time to be served during probation

PROBATION:

- Serve _____ Year, _____ Month(s) Probation
- Time to be Consecutive Concurrent with **Count** _____
- Pay \$_____ monthly for Cost of Supervision to Community Corrections
- Standard conditions of Probation imposed (F.S. 948.03)
- May terminate upon compliance after _____ months
- _____ apply for early termination
- Electronic monitoring required as part of probation
- Mail or phone reporting is authorized

COMMUNITY SERVICE:

- You shall complete _____ hours of Community Service work
- You may buy out _____ hours of Community service at the rate of \$_____ per hour
- You qualify to perform community service hours in lieu of paying court ordered court costs and fines at the rate of \$_____ per hour
- You are ordered to complete Community Service work during the term of your probation if you are unable to pay your fine.
- Community service work is authorized for all but \$_____ of the court ordered Costs and Fines at the rate of \$_____ per hour.
- Community Service Work shall be complete within _____ months

FINES:

- \$_____ Fine

The Defendant shall pay the following Court Costs:

- \$273** Mandatory Court Costs
(F.S. 938.01, 938.03, 938.05, 938.06, 938.15, 938.19, 938.27, 939.185, 775.083(2), Escambia County Ord 34-7 and 34-9)
- \$456** DUI Court Costs
(F.S. 938.01, 938.03, 938.05, 938.06, 938.07, 938.13, 938.15, 938.19, 938.27, 939.185, 775.083(2), 318.18(17), 318.18(18), Escambia County Ord 34-7 and 34-9)
- \$423** BUI Court Costs
(F.S. 938.01, 938.03, 938.05, 938.06, 938.07, 938.13, 938.15, 938.19, 938.27, 939.185, 775.083(2), Escambia County Ord 34-7 and 34-9)
- \$201** Domestic Violence Trust Fund (F.S. 938.08)
- \$151** Rape Crisis Trust Fund (F.S. 938.085)
- \$151** Crimes against Minors (F.S. 938.10)
- \$15** Misdemeanor Crimes Involving Drugs/Alcohol (F.S. 938.13)
- \$5,000** Prostitution (F.S. 796.07(6))
- \$65** Reckless Driving / Racing on Highway (F.S. 318.18(20))
- \$30** State Facility Surcharge (F.S. 318.18)
- \$ _____ County Drug Abuse Trust Fund (F.S. 938.21)
- \$ _____ Additional Costs of Prosecution (F.S. 938.27)
- \$50** Public Defender Application (F.S. 27.52) Waived
- \$50** or the higher cost of \$ _____ for legal assistance (F.S. 938.29) Waived
- \$100** FDLE (F.S. 938.055)
- \$ _____ Surcharge on all fines (F.S. 938.04)
- \$5** EMS Trust Fund (F.S. 316.192 / 316.061)
- \$3** State Radio (F.S. 318.18(17))
- \$ _____ Cost of Investigation to _____ (F.S. 938.27)
- \$ _____

The Defendant shall comply with the following Special Conditions of Probation:

- Restitution: \$ _____ to be paid to _____
- Restitution: State Attorney has _____ days to file and defense has _____ days to object
 - If defense fails to object, the amount stands
 - The Court reserves jurisdiction to determine restitution
- Restitution **may** be paid into the court registry
- Counseling: Complete **Alcohol** counseling
- DVIP: Complete a Domestic Violence Intervention Program
- Complete Shoplifter's Alternative class
- Evaluation: Must obtain a/an **alcohol** evaluation _____
- Treatment: Must begin complete treatment deemed necessary by **alcohol** evaluation _____
- May not **consume** alcohol drugs
- Alcohol/Drug Testing: Conduct **alcohol** testing **randomly** at your expense
- Do not test positive for **alcohol** after _____ Days.
- DUI School: Must complete **1st Offender** DUI School
- Driving School: Must complete 1st Offender Multiple Offender Driving School

- Interlock _____ months with Business Purposes License
- Impact Panel: Must attend _____ Drunk Driving Impact Panel(s)
- Your vehicle will be impounded for _____ days
- You may not operate a motor vehicle
- Show proof of a valid clear driver's license
- You must show proof of a valid registration/tag for your vehicle, proof vehicle not registered to you, or affidavit
- You must show proof of valid insurance or affidavit
- Your Driver's License is Suspended Revoked for _____ months
- No Contact: Have no contact with _____
- Pay Civil Infractions during probation, case number(s) _____
- Pay all Court Costs and Fines during Probation
- Seek** full time employment or school
- Perform _____ job searches per week if working less than _____ hours per week;
begin within _____ days of starting Supervision;
must continue until hired
- Abide by terms of _____
- Letter of Apology to _____

Other Provisions: _____

- You must pay all Court Costs and Fines or enter into a Payment Plan with the Clerk of Court;
 - If you fail to do so by _____, you must appear in court on _____ **at** _____.
 - If you fail to do so by **07/17/2018**, your driver license will be suspended.
 - If you fail to do so by _____, all fines and court costs will be reduced to a lien.

- It is determined that you are unable to pay the amounts due and your monetary obligations, consisting of Court Costs and Fees, are reduced to a Civil Judgment, which shall bear interest at the maximum rate allowed by law. (F.S. 55.03)
 - Any remaining balance due on your civil judgment after **90** days from the date of this order will be referred to a collections agency.
 - Your driver's license will be suspended.

If you fail to complete the terms of this order, including payment of all costs, fees and fines, as required, you may be subject to Contempt of Court proceedings.

If a bail bond is currently in effect as to this case and has not been forfeited, that bond is hereby cancelled and the surety is discharged from liability on that bond. A cash bond may be applied towards outstanding financial obligations as allowed per F.S. 903.286.

Any active warrants, capias or summons in this case against this Defendant are hereby quashed.

The Defendant has **30** days from the date of this Order and Judgment in which to file an appeal of the findings and sentence in this matter by filing a Notice of Appeal with the Clerk of Court.

NUNC PRO TUNC TO: 04/03/2018

DONE AND ORDERED in Escambia County Florida.

eSigned by COUNTY COURT JUDGE JENNIFER J FRYDRYCHOWICZ
on 04/03/2018 08:52:52 zmiHEAS

I hereby certify that a true and correct copy of this document was sent via electronic mail to the State Attorney and Defense Counsel of Record or Defendant by US Mail if there is no Defense Counsel of Record.

PAM CHILDERS, CLERK OF THE CIRCUIT COURT

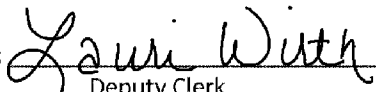
By: 
Deputy Clerk

