



CERTIFICATION OF TAX DEED APPLICATION

Sections 197.502 and 197.542, Florida Statutes

DR-513
Rule 12D-16.002 F.A.C
Effective 07/19
Page 1 of 2

1021-14

Part 1: Tax Deed Application Information

Applicant Name Applicant Address	JUAN C CAPOTE MIKON FINANCIAL SERVICES, INC. AND OCEAN BANK 780 NW 42 AVE #300 MIAMI, FL 33126	Application date	Sep 25, 2020
Property description	GOLDING BILLY C JR & AUGUSTA L 120 RUE MAX AVE PENSACOLA, FL 32507 120 RUE MAX AVE 08-0678-000 LT 18 BLK 29 OR 3991 P 495 RE S/D OF BLK B 2ND ADDN TO AERO VISTA PB 2 P 81/81A CA 196	Certificate #	2018 / 3996
		Date certificate issued	06/01/2018

Part 2: Certificates Owned by Applicant and Filed with Tax Deed Application

Column 1 Certificate Number	Column 2 Date of Certificate Sale	Column 3 Face Amount of Certificate	Column 4 Interest	Column 5: Total (Column 3 + Column 4)
# 2018/3996	06/01/2018	356.82	17.84	374.66
→Part 2: Total*				374.66

Part 3: Other Certificates Redeemed by Applicant (Other than County)

Column 1 Certificate Number	Column 2 Date of Other Certificate Sale	Column 3 Face Amount of Other Certificate	Column 4 Tax Collector's Fee	Column 5 Interest	Total (Column 3 + Column 4 + Column 5)
# 2020/4121	06/01/2020	371.54	6.25	18.58	396.37
# 2019/3794	06/01/2019	364.71	6.25	18.24	389.20
Part 3: Total*					785.57

Part 4: Tax Collector Certified Amounts (Lines 1-7)

1. Cost of all certificates in applicant's possession and other certificates redeemed by applicant (*Total of Parts 2 + 3 above)	1,160.23
2. Delinquent taxes paid by the applicant	0.00
3. Current taxes paid by the applicant	0.00
4. Property information report fee	200.00
5. Tax deed application fee	175.00
6. Interest accrued by tax collector under s.197.542, F.S. (see Tax Collector Instructions, page 2)	0.00
7. Total Paid (Lines 1-6)	1,535.23

I certify the above information is true and the tax certificates, interest, property information report fee, and tax collector's fees have been paid, and that the property information statement is attached.

Sign here: *Dawn Mustain* Escambia, Florida
 Signature, Tax Collector or Designee Date October 5th, 2020

Send this certification to the Clerk of Court by 10 days after the date signed. See Instructions on Page 2

Part 5: Clerk of Court Certified Amounts (Lines 8-14)	
8. Processing tax deed fee	
9. Certified or registered mail charge	
10. Clerk of Court advertising, notice for newspaper, and electronic auction fees	
11. Recording fee for certificate of notice	
12. Sheriff's fees	
13. Interest (see Clerk of Court Instructions, page 2)	
14. Total Paid (Lines 8-13)	
15. Plus one-half of the assessed value of homestead property, if applicable under s. 197.502(6)(c), F.S.	19,268.50
16. Statutory opening bid (total of Lines 7, 14, 15, and 16 if applicable)	
Sign here: _____ Date of sale <u>10-04-2021</u> Signature, Clerk of Court or Designee	

INSTRUCTIONS

+ 6.25

Tax Collector (complete Parts 1-4)

Part 2: Certificates Owned by Applicant and Filed with Tax Deed Application

Enter the Face Amount of Certificate in Column 3 and the Interest in Column 4 for each certificate number. Add Columns 3 and 4 and enter the amount in Column 5.

Part 3: Other Certificates Redeemed by Applicant (Other than County)

Total. Add the amounts in Columns 3, 4 and 5

Part 4: Tax Collector Certified Amounts (Lines 1-7)

Line 1, enter the total of Part 2 plus the total of Part 3 above.

Total Paid, Line 7: Add the amounts of Lines 1-6

Line 6, Interest accrued by tax collector. Calculate the 1.5 percent interest accrued from the month after the date of application through the month this form is certified to the clerk. Enter the amount to be certified to the clerk on **Line 6**. The interest calculated by the tax collector stops before the interest calculated by the clerk begins. See Section 197.542, F.S., and Rule 12D-13.060(3), Florida Administrative Code.

The tax collector's interest for redemption at the time of the tax deed application is a cost of redemption, which encompasses various percentages of interest on certificates and omitted or delinquent taxes under Section 197.502, F.S. This interest is calculated before the tax collector calculates the interest in Section 197.542, F.S.

Attach certified statement of names and addresses of persons who must be notified before the sale of the property. Send this form and any required attachments to the Clerk of Court within 10 days after it is signed.

Clerk of Court (complete Part 5)

Line 13: Interest is calculated at the rate of 1.5 percent per month starting from the first day of the month after the month of certification of this form through the last day of the month in which the sale will be held. Multiply the calculated rate by the total of **Line 7**, minus **Line 6**, plus **Lines 8** through **12**. Enter the amount on **Line 13**.

Line 14: Enter the total of Lines 8-13. Complete Lines 15-18, if applicable.

APPLICATION FOR TAX DEED

Section 197.502, Florida Statutes

512
R. 12/16

Application Number: 2000753

To: Tax Collector of ESCAMBIA COUNTY, Florida

I,
JUAN C CAPOTE
MIKON FINANCIAL SERVICES, INC. AND OCEAN BANK
780 NW 42 AVE #300
MIAMI, FL 33126,

hold the listed tax certificate and hereby surrender the same to the Tax Collector and make tax deed application thereon:

Account Number	Certificate No.	Date	Legal Description
08-0678-000	2018/3996	06-01-2018	LT 18 BLK 29 OR 3991 P 495 RE S/D OF BLK B 2ND ADDN TO AERO VISTA PB 2 P 81/81A CA 196

I agree to:

- pay any current taxes, if due and
- redeem all outstanding tax certificates plus interest not in my possession, and
- pay all delinquent and omitted taxes, plus interest covering the property.
- pay all Tax Collector's fees, property information report costs, Clerk of the Court costs, charges and fees, and Sheriff's costs, if applicable.

Attached is the tax sale certificate on which this application is based and all other certificates of the same legal description which are in my possession.

Electronic signature on file
JUAN C CAPOTE
MIKON FINANCIAL SERVICES, INC. AND OCEAN BANK
780 NW 42 AVE #300
MIAMI, FL 33126

09-25-2020
Application Date

Applicant's signature



Chris Jones Escambia County Property Appraiser

[Real Estate Search](#)

[Tangible Property Search](#)

[Sale List](#)

← [Navigate Mode](#) [Account](#) [Reference](#) →

[Printer Friendly Version](#)

General Information	
Reference:	5025305012018029
Account:	080678000
Owners:	GOLDING BILLY C JR & AUGUSTA L
Mail:	120 RUE MAX AVE PENSACOLA, FL 32507
Situs:	120 RUE MAX AVE 32507
Use Code:	SINGLE FAMILY RESID
Taxing Authority:	COUNTY MSTU
Tax Inquiry:	Open Tax Inquiry Window
Tax Inquiry link courtesy of Scott Lunsford Escambia County Tax Collector	

Assessments				
Year	Land	Imprv	Total	Cap Val
2020	\$8,000	\$47,052	\$55,052	\$39,423
2019	\$8,000	\$43,915	\$51,915	\$38,537
2018	\$8,000	\$40,779	\$48,779	\$37,819
Disclaimer				
Market Value Breakdown Letter				
Tax Estimator				
File for New Homestead Exemption Online				
Report Storm Damage				

Sales Data					
Sale Date	Book	Page	Value	Type	Official Records (New Window)
06/1996	3991	495	\$35,000	WD	View Instr
02/1987	2349	857	\$22,000	WD	View Instr
12/1983	1859	121	\$8,800	WD	View Instr
01/1974	770	401	\$7,700	WD	View Instr
Official Records Inquiry courtesy of Pam Childers Escambia County Clerk of the Circuit Court and Comptroller					

2020 Certified Roll Exemptions
HOMESTEAD EXEMPTION
Legal Description
LT 18 BLK 29 OR 3991 P 495 RE S/D OF BLK B 2ND ADDN TO AERO VISTA PB 2 P 81/81A CA 196
Extra Features
None

Parcel Information [Launch Interactive Map](#)

Section Map Id: CA196

Approx. Acreage: 0.1690

Zoned: MDR

Evacuation & Flood Information [Open Report](#)

[View Florida Department of Environmental Protection\(DEP\) Data](#)

Buildings	
Address: 120 RUE MAX AVE, Year Built: 1950, Effective Year: 1950, PA Building ID#: 87164	
Structural Elements	
DECOR/MILLWORK-AVERAGE	

DWELLING UNITS-1
EXTERIOR WALL-ASBESTOS SIDING
EXTERIOR WALL-SIDING-SHT.AVG.
FLOOR COVER-HARDWOOD/PARQET
FOUNDATION-WOOD/SUB FLOOR
HEAT/AIR-CENTRAL H/AC
INTERIOR WALL-DRYWALL-PLASTER
INTERIOR WALL-PANEL-PLYWOOD
NO. PLUMBING FIXTURES-3
NO. STORIES-1
ROOF COVER-COMPOSITION SHG
ROOF FRAMING-GABLE
STORY HEIGHT-0
STRUCTURAL FRAME-WOOD FRAME

 Areas - 1287 Total SF

BASE AREA - 756
OPEN PORCH FIN - 56
UTILITY FIN - 475

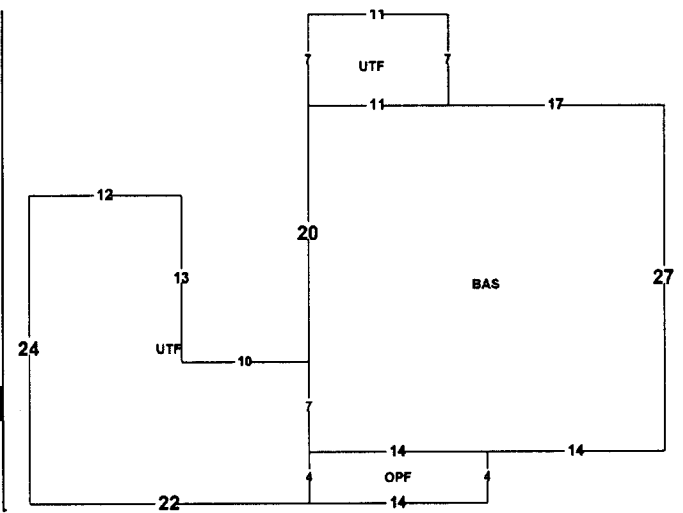

Images



10/23/18

The primary use of the assessment data is for the preparation of the current year tax roll. No responsibility or liability is assumed for inaccuracies or errors.

NOTICE OF APPLICATION FOR TAX DEED

NOTICE IS HEREBY GIVEN, That **MIKON FINANCIAL SERVICES INC AND OCEAN BANK** holder of **Tax Certificate No. 03996**, issued the **1st day of June, A.D., 2018** has filed same in my office and has made application for a tax deed to be issued thereon. Said certificate embraces the following described property in the County of Escambia, State of Florida, to wit:

LT 18 BLK 29 OR 3991 P 495 RE S/D OF BLK B 2ND ADDN TO AERO VISTA PB 2 P 81/81A CA 196

SECTION 50, TOWNSHIP 2 S, RANGE 30 W

TAX ACCOUNT NUMBER 080678000 (1021-14)

The assessment of the said property under the said certificate issued was in the name of

BILLY C GOLDING JR and AUGUSTA L GOLDING

Unless said certificate shall be redeemed according to law, the property described therein will be sold to the highest bidder at public auction at 9:00 A.M. on the **first Monday** in the month of October, which is the **4th day of October 2021**.

Dated this 23rd day of November 2020.

In accordance with the AMERICANS WITH DISABILITIES ACT, if you are a person with a disability who needs special accommodation in order to participate in this proceeding you are entitled to the provision of certain assistance. Please contact Emily Hogg not later than seven days prior to the proceeding at Escambia County Government Complex, 221 Palafox Place Ste 110, Pensacola FL 32502. Telephone: 850-595-3793.

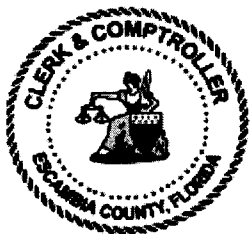

PAM CHILDERS
CLERK OF THE CIRCUIT COURT
ESCAMBIA COUNTY, FLORIDA

By:
Emily Hogg
Deputy Clerk



PROPERTY INFORMATION REPORT
3050 Concho Drive, Pensacola, Florida 32507 | Phone: 850-466-3077

THE ATTACHED REPORT IS ISSUED TO:

SCOTT LUNSFORD, ESCAMBIA COUNTY TAX COLLECTOR

TAX ACCOUNT #: 08-0678-000 CERTIFICATE #: 2018-3996

THIS REPORT IS NOT TITLE INSURANCE. THE LIABILITY FOR ERRORS OR OMISSIONS IN THIS REPORT IS LIMITED TO THE PERSON(S) EXPRESSLY IDENTIFIED BY NAME IN THE PROPERTY INFORMATION REPORT AS THE RECIPIENT(S) OF THE PROPERTY INFORMATION REPORT.

The attached Report prepared in accordance with the instructions given by the user named above includes a listing of the owner(s) of record of the land described herein together with current and delinquent ad valorem tax information and a listing and copies of all open or unsatisfied leases, mortgages, judgments and encumbrances recorded in the Official Record Books of Escambia County, Florida that appear to encumber the title to said land as listed on page 2 herein. It is the responsibility of the party named above to verify receipt of each document listed. If a copy of any document listed is not received, the office issuing this Report must be contacted immediately.

This Report is subject to: Current year taxes; taxes and assessments due now or in subsequent years; oil, gas, and mineral or any subsurface rights of any kind or nature; easements, restrictions and covenants of record; encroachments, overlaps, boundary line disputes, and any other matters that would be disclosed by an accurate survey and inspection of the premises.

This Report does not insure or guarantee the validity or sufficiency of any document attached, nor is it to be considered a title insurance policy, an opinion of title, a guarantee of title, or as any other form of guarantee or warranty of title.

Use of the term "Report" herein refers to the Property Information Report and the documents attached hereto.

Period Searched: July 21, 2001 to and including July 21, 2021 Abstractor: Cody Campbell

BY

A handwritten signature in black ink, appearing to read "Michael A. Campbell".

Michael A. Campbell,
As President

Dated: July 26, 2021

**PROPERTY INFORMATION REPORT
CONTINUATION PAGE**

July 19, 2021

Tax Account #:08-0678-000

1. The Grantee(s) of the last deed(s) of record is/are: **BILLY C. GOLDING, JR. AND AUGUSTA GOLDING**

By Virtue of Warranty Deed recorded 06/13/1996 – OR 3991/495
2. The land covered by this Report is: **See Attached Exhibit “A”**
3. The following unsatisfied mortgages, liens, and judgments affecting the land covered by this Report appear of record:
 - a. **Lien in favor of Neighborhood Enterprise Foundation, Inc. for Escambia County recorded 1/16/2013 – OR 6962/815**
4. Taxes:

Taxes for the year(s) 2017-2020 are delinquent.
Tax Account #:08-0678-000
Assessed Value: \$39,423
Exemptions: HOMESTEAD EXEMPTION
5. We find the following HOA names in our search (if a condominium, the condo docs book and page are included for your review): **NONE**

Payment of any special liens/assessments imposed by City, County, and/or State.

Note: Escambia County and/or local municipalities may impose special liens/assessments. These liens/assessments are not discovered in a title search or shown above. These special assessments typically create a lien on real property. The entity that governs subject property must be contacted to verify payment status.

PROPERTY INFORMATION REPORT

July 26, 2021

Tax Account #:08-0678-000

**LEGAL DESCRIPTION
EXHIBIT "A"**

**LT 18 BLK 29 OR 3991 P 495 RE S/D OF BLK B 2ND ADDN TO AERO VISTA PB 2 P 81/81A CA
196**

SECTION 50, TOWNSHIP 2 S, RANGE 30 W

TAX ACCOUNT NUMBER 08-0678-000 (1021-14)

10.50
245.00

This Warranty Deed

OR BK3991 Pg0495
INSTRUMENT 00302366

Made this 7th day of June A.D. 19 96
by Patricia S. Baggett, a married woman

D S PD \$245.00
Mort \$0.00 ASUM \$0.00
JUNE 13, 1996
Ernie Lee Magaha,
Clerk of the Circuit Court
St. S. Award D.C.

hereinafter called the grantor, to
Billy C. Golding, Jr. and Augusta L.
Golding, husband and wife

whose post office address is:
120 Rue Max Street
Pensacola, Florida 32506
Grantees' SSN: 263-35-0331

hereinafter called the grantee:
(Whenever used herein the term "grantor" and "grantee" include all the parties to this instrument and the heirs, legal representatives and assigns of individuals, and the successors and assigns of corporations)

Witnesseth, that the grantor, for and in consideration of the sum of \$ 10.00 and other valuable considerations, receipt whereof is hereby acknowledged, hereby grants, bargains, sells, aliens, remises, releases, conveys and confirms unto the grantee, all that certain land situate in Escambia County, Florida, viz:

Lot 18 Block 29 Aero Vista Second Addition being a portion of Section 50 & 51 Township 28 Range 30 West Escambia County, Florida according to plat recorded in Plat Book 2 Page 81 & 81A of the Public Records of said county.

SUBJECT TO Covenants, restrictions, easements of record and taxes for the current year.

Said property is not the homestead of the Grantor(s) under the laws and constitution of the State of Florida in that neither Grantor(s) or any members of the household of Grantor(s) reside thereon.

Parcel Identification Number: 50-28-30-5012-018-029

Together with all the tenements, hereditaments and appurtenances thereto belonging or in anywise appertaining. To Have and to Hold, the same in fee simple forever.

And the grantor hereby covenants with said grantee that the grantor is lawfully seized of said land in fee simple; that the grantor has good right and lawful authority to sell and convey said land; that the grantor hereby fully warrants the title to said land and will defend the same against the lawful claims of all persons whomsoever; and that said land is free of all encumbrances except taxes accruing subsequent to December 31, 19

In Witness Whereof, the said grantor has signed and sealed these presents the day and year first above written.

Signed, sealed and delivered in our presence:

Name: Charles Stallion

Name & Address: Patricia S. Baggett LS

Name: Marilyn Unger

Name & Address: LS

Name: _____

Name & Address: 10050 Beulah Road
Pensacola, Florida 32526 LS

Name: _____

Name & Address: LS

State of Florida
County of Escambia

The foregoing instrument was acknowledged before me this 7th day of June, 19 96, by Patricia S. Baggett, a married woman

who is personally known to me or who has produced a current driver's license as identification.

Print Name:
Notary Public
My Commission Expires:

PREPARED BY: Marilyn Unger
RECORD & RETURN TO:
Lawyers Title Agency of North Florida, Inc.
2100 Creighton Road
Pensacola, Florida 32504
File No: 3A-50090

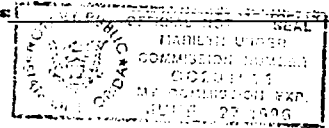

**RESIDENTIAL SALES
ABUTTING ROADWAY
MAINTENANCE DISCLOSURE**

ATTENTION: Pursuant to Escambia County Code of Ordinances Chapter 1-29.2, Article V, sellers of residential lots are required to disclose to buyers whether abutting roadways will be maintained by Escambia County. The disclosure must additionally provide that Escambia County does not accept roads for maintenance that have not been built or improved to meet county standards. Escambia County Code of Ordinances Chapter 1-29.2, Article V requires this disclosure be attached along with other attachments to the deed or other method of conveyance required to be made part of the public records of Escambia County, Florida. Note: Acceptance for filing by County employees of this disclosure shall in no way be construed as an acknowledgment by the County of the veracity of any disclosure statement.

Name of Roadway: 120 Rue Max Street

Legal Address of Property: 120 Rue Max Street

The County () has accepted () has not accepted the abutting roadway for maintenance.

This form completed by: Patricia S. Baggett
10050 Beulah Road
Pensacola, Florida 32526

AS TO SELLER(S):

Charles Stallion
Witness: Charles Stallion

Patricia S. Baggett
Patricia S. Baggett

Witness: Marilyn Unger

AS TO BUYER(S):

Charles Stallion
Witness: Charles Stallion

Billy C. Golding, Jr.
Billy C. Golding, Jr.

Witness: Marilyn Unger

This form approved by the
Escambia County Board of
County Commissioners
Effective: 4/15/95

Instrument 00302366
Filed and recorded in the
Official Records
JUNE 13, 1996
at 12:00 P.M.
ERNIE LEE MAGAHA,
CLERK OF THE CIRCUIT COURT
Escambia County,
Florida

Recorded in Public Records 01/16/2013 at 02:13 PM OR Book 6962 Page 815, Instrument #2013003601, Pam Childers Clerk of the Circuit Court Escambia County, FL Recording \$10.00

ESCAMBIA COUNTY
COMMUNITY DEVELOPMENT BLOCK GRANT PROGRAM
Escambia County, Florida

LIEN AGREEMENT

Applicant's Name	Address of Property	Lot(s)
<u>Bill C. Golding, Jr. & Augusta L. Golding</u>	<u>120 Rue Max Avenue</u> <u>Pensacola, Florida 32505</u>	<u>18</u> Block <u>29</u>
	(X) Deferred Grant Housing Rehabilitation Sewer Connection Assistance	Book <u>3991</u> Page <u>495</u> Tract <u>22</u>
Total Amount of Lien		
\$ <u>3,035.00</u>		

I, the undersigned, as owner of said property, do hereby agree that I will continue to occupy and maintain the rehabilitated housing unit for at least a five (5) year period from the **10th day of January, 2013**. I will not sell, transfer ownership, or rent the property to any other person or persons during this five (5) year period. The lien will depreciate at the rate of twenty percent (20%) per year on the anniversary date for a period of five (5) years. I understand that this lien will not be subordinated under any circumstances.

If the property is sold, ownership is transferred to another party or parties, or the property is converted to rental occupancy during the five (5) year period, I further agree that I or my heir(s) will repay the Escambia County Community Development Block Grant Program the undepreciated portion of the total lien amount cited above.

This lien will expire and automatically cancel on January 9, 2018.

January 10, 2013
Date

Bill C. Golding, Jr.
Signature
(Bill C. Golding, Jr.)

Augusta L. Golding
Signature
(Augusta L. Golding)

STATE OF FLORIDA
COUNTY OF ESCAMBIA

The foregoing instrument was acknowledged before me this 10th day of January, 20 13, by Bill C. Golding, Jr. & Augusta L. Golding who is personally known to me or who has produced Florida Driver License(s) as identification and who did (did not) take an oath.

Derrick Andre Williams
Signature



Notary Public

This instrument was prepared by: **Neighborhood Enterprise Foundation, Inc.**
for Escambia County
Post Office Box 18178
Pensacola, Florida 32523-8178

**STATE OF FLORIDA
COUNTY OF ESCAMBIA**

**CERTIFICATE OF NOTICE OF MAILING
NOTICE OF APPLICATION FOR TAX DEED**

CERTIFICATE # 03996 of 2018

I, PAM CHILDERS, CLERK OF THE CIRCUIT COURT OF ESCAMBIA COUNTY, FLORIDA, do hereby certify that I did on August 19, 2021, mail a copy of the foregoing Notice of Application for Tax Deed, addressed to:

BILLY C GOLDING JR 120 RUE MAX AVE PENSACOLA, FL 32507	AUGUSTA L GOLDING 120 RUE MAX AVE PENSACOLA, FL 32507
ESCAMBIA COUNTY / COUNTY ATTORNEY 221 PALAFOX PLACE STE 430 PENSACOLA FL 32502	NEIGHBORHOOD ENTERPRISE DIVISION PO BOX 18178 PENSACOLA, FL 32523

WITNESS my official seal this 19th day of August 2021.

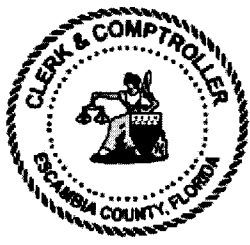

PAM CHILDERS
CLERK OF THE CIRCUIT COURT
ESCAMBIA COUNTY, FLORIDA

By:
Emily Hogg
Deputy Clerk

WARNING

THERE ARE UNPAID TAXES ON PROPERTY WHICH YOU OWN OR IN WHICH YOU HAVE A LEGAL INTEREST. THE PROPERTY WILL BE SOLD AT PUBLIC AUCTION ON October 4, 2021, UNLESS THE TAXES ARE PAID. SHOULD YOU NEED FURTHER INFORMATION CONTACT THE CLERK OF THE CIRCUIT COURT IMMEDIATELY AT THE COUNTY COURTHOUSE IN PENSACOLA, FLORIDA, OR CALL 850-595-3793.

NOTICE OF APPLICATION FOR TAX DEED

NOTICE IS HEREBY GIVEN, That **MIKON FINANCIAL SERVICES INC AND OCEAN BANK** holder of **Tax Certificate No. 03996**, issued the **1st day of June, A.D., 2018** has filed same in my office and has made application for a tax deed to be issued thereon. Said certificate embraces the following described property in the County of Escambia, State of Florida, to wit:

LT 18 BLK 29 OR 3991 P 495 RE S/D OF BLK B 2ND ADDN TO AERO VISTA PB 2 P 81/81A CA 196

SECTION 50, TOWNSHIP 2 S, RANGE 30 W

TAX ACCOUNT NUMBER 080678000 (1021-14)

The assessment of the said property under the said certificate issued was in the name of

BILLY C GOLDING JR and AUGUSTA L GOLDING

Unless said certificate shall be redeemed according to law, the property described therein will be sold to the highest bidder at public auction at 9:00 A.M. on the **first Monday** in the month of October, which is the **4th day of October 2021**.

Dated this 17th day of August 2021.

In accordance with the AMERICANS WITH DISABILITIES ACT, if you are a person with a disability who needs special accommodation in order to participate in this proceeding you are entitled to the provision of certain assistance. Please contact Emily Hogg not later than seven days prior to the proceeding at Escambia County Government Complex, 221 Palafox Place Ste 110, Pensacola FL 32502. Telephone: 850-595-3793.



PAM CHILDERS
CLERK OF THE CIRCUIT COURT
ESCAMBIA COUNTY, FLORIDA

By:
Emily Hogg
Deputy Clerk

WARNING

THERE ARE UNPAID TAXES ON PROPERTY WHICH YOU OWN OR IN WHICH YOU HAVE A LEGAL INTEREST. THE PROPERTY WILL BE SOLD AT PUBLIC AUCTION ON October 4, 2021, UNLESS THE TAXES ARE PAID. SHOULD YOU NEED FURTHER INFORMATION CONTACT THE CLERK OF THE CIRCUIT COURT IMMEDIATELY AT THE COUNTY COURTHOUSE IN PENSACOLA, FLORIDA, OR CALL 850-595-3793.

NOTICE OF APPLICATION FOR TAX DEED

NOTICE IS HEREBY GIVEN, That **MIKON FINANCIAL SERVICES INC AND OCEAN BANK** holder of Tax Certificate No. 03996, issued the 1st day of June, A.D., 2018 has filed same in my office and has made application for a tax deed to be issued thereon. Said certificate embraces the following described property in the County of Escambia, State of Florida, to wit:

LT 18 BLK 29 OR 3991 P 495 RE S/D OF BLK B 2ND ADDN TO AERO VISTA PB 2 P 81/81A CA 196

SECTION 50, TOWNSHIP 2 S, RANGE 30 W

TAX ACCOUNT NUMBER 080678000 (1021-14)

The assessment of the said property under the said certificate issued was in the name of

BILLY C GOLDING JR and AUGUSTA L GOLDING

Unless said certificate shall be redeemed according to law, the property described therein will be sold to the highest bidder at public auction at 9:00 A.M. on the first Monday in the month of October, which is the 4th day of October 2021.

Dated this 17th day of August 2021.

In accordance with the AMERICANS WITH DISABILITIES ACT, if you are a person with a disability who needs special accommodation in order to participate in this proceeding you are entitled to the provision of certain assistance. Please contact Emily Hogg not later than seven days prior to the proceeding at Escambia County Government Complex, 221 Palafox Place Ste 110, Pensacola FL 32502. Telephone: 850-595-3793.

Post Property:

120 RUE MAX AVE 32507



PAM CHILDERS
CLERK OF THE CIRCUIT COURT
ESCAMBIA COUNTY, FLORIDA

By:
Emily Hogg
Deputy Clerk

WARNING

THERE ARE UNPAID TAXES ON PROPERTY WHICH YOU OWN OR IN WHICH YOU HAVE A LEGAL INTEREST. THE PROPERTY WILL BE SOLD AT PUBLIC AUCTION ON October 4, 2021, UNLESS THE TAXES ARE PAID. SHOULD YOU NEED FURTHER INFORMATION CONTACT THE CLERK OF THE CIRCUIT COURT IMMEDIATELY AT THE COUNTY COURTHOUSE IN PENSACOLA, FLORIDA, OR CALL 850-595-3793.

NOTICE OF APPLICATION FOR TAX DEED

NOTICE IS HEREBY GIVEN, That **MIKON FINANCIAL SERVICES INC AND OCEAN BANK** holder of **Tax Certificate No. 03996**, issued the 1st day of **June, A.D., 2018** has filed same in my office and has made application for a tax deed to be issued thereon. Said certificate embraces the following described property in the County of Escambia, State of Florida, to wit:

LT 18 BLK 29 OR 3991 P 495 RE S/D OF BLK B 2ND ADDN TO AERO VISTA PB 2 P 81/81A CA 196

SECTION 50, TOWNSHIP 2 S, RANGE 30 W

TAX ACCOUNT NUMBER 080678000 (1021-14)

The assessment of the said property under the said certificate issued was in the name of

BILLY C GOLDING JR and AUGUSTA L GOLDING

Unless said certificate shall be redeemed according to law, the property described therein will be sold to the highest bidder at public auction at 9:00 A.M. on the **first Monday** in the month of **October**, which is the **4th day of October 2021**.

Dated this 17th day of August 2021.

In accordance with the AMERICANS WITH DISABILITIES ACT, if you are a person with a disability who needs special accommodation in order to participate in this proceeding you are entitled to the provision of certain assistance. Please contact Emily Hogg not later than seven days prior to the proceeding at Escambia County Government Complex, 221 Palafox Place Ste 110, Pensacola FL 32502. Telephone: 850-595-3793.

Personal Services:

BILLY C GOLDING JR
120 RUE MAX AVE
PENSACOLA, FL 32507

PAM CHILDERS
CLERK OF THE CIRCUIT COURT
ESCAMBIA COUNTY, FLORIDA



By:
Emily Hogg
Deputy Clerk

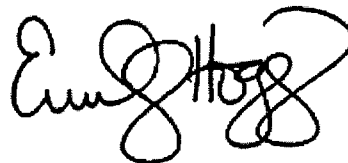

WARNING

THERE ARE UNPAID TAXES ON PROPERTY WHICH YOU OWN OR IN WHICH YOU HAVE A LEGAL INTEREST. THE PROPERTY WILL BE SOLD AT PUBLIC AUCTION ON October 4, 2021, UNLESS THE TAXES ARE PAID. SHOULD YOU NEED FURTHER INFORMATION CONTACT THE CLERK OF THE CIRCUIT COURT IMMEDIATELY AT THE COUNTY COURTHOUSE IN PENSACOLA, FLORIDA, OR CALL 850-595-3793.

NOTICE OF APPLICATION FOR TAX DEED

NOTICE IS HEREBY GIVEN, That **MIKON FINANCIAL SERVICES INC AND OCEAN BANK** holder of Tax Certificate No. 03996, issued the 1st day of June, A.D., 2018 has filed same in my office and has made application for a tax deed to be issued thereon. Said certificate embraces the following described property in the County of Escambia, State of Florida, to wit:

LT 18 BLK 29 OR 3991 P 495 RE S/D OF BLK B 2ND ADDN TO AERO VISTA PB 2 P 81/81A CA 196

SECTION 50, TOWNSHIP 2 S, RANGE 30 W

TAX ACCOUNT NUMBER 080678000 (1021-14)

The assessment of the said property under the said certificate issued was in the name of

BILLY C GOLDING JR and AUGUSTA L GOLDING

Unless said certificate shall be redeemed according to law, the property described therein will be sold to the highest bidder at public auction at 9:00 A.M. on the **first** Monday in the month of October, which is the **4th** day of **October 2021**.

Dated this 17th day of August 2021.

In accordance with the AMERICANS WITH DISABILITIES ACT, if you are a person with a disability who needs special accommodation in order to participate in this proceeding you are entitled to the provision of certain assistance. Please contact Emily Hogg not later than seven days prior to the proceeding at Escambia County Government Complex, 221 Palafox Place Ste 110, Pensacola FL 32502. Telephone: 850-595-3793.

Personal Services:

AUGUSTA L GOLDING
120 RUE MAX AVE
PENSACOLA, FL 32507

PAM CHILDERS
CLERK OF THE CIRCUIT COURT
ESCAMBIA COUNTY, FLORIDA



By:
Emily Hogg
Deputy Clerk



PAM CHILDERS
 CLERK OF THE CIRCUIT COURT
 ARCHIVES AND RECORDS
 CHILDSUPPORT
 CIRCUIT CIVIL
 CIRCUIT CRIMINAL
 COUNTY CIVIL
 COUNTY CRIMINAL
 DOMESTIC RELATIONS
 FAMILY LAW
 JURY ASSEMBLY
 JUVENILE
 MENTAL HEALTH
 MIS
 OPERATIONAL SERVICES
 PROBATE
 TRAFFIC



BRANCH OFFICES
ARCHIVES AND RECORDS
JUVENILE DIVISION
CENTURY

CLERK TO THE BOARD OF
 COUNTY COMMISSIONERS
 OFFICIAL RECORDS
 COUNTY TREASURY
 AUDITOR

COUNTY OF ESCAMBIA
OFFICE OF THE
CLERK OF THE CIRCUIT COURT

PAM CHILDERS, CLERK OF THE CIRCUIT COURT
Tax Certificate Redeemed From Sale
Account: 080678000 Certificate Number: 003996 of 2018

Payor: BILLY C GOLDING JR 120 RUE MAX AVE PENSACOLA, FL 32507 Date 09/15/2021

Clerk's Check #	5506424866	Clerk's Total	\$558.07
Tax Collector Check #	1	Tax Collector's Total	\$1,840.85
		Postage	\$24.00
		Researcher Copies	\$0.00
		Recording	\$10.00
		Prep Fee	\$7.00
		Total Received	\$2,439.92

PAM CHILDERS
 Clerk of the Circuit Court

Received By:
 Deputy Clerk

PAM CHILDERS
 CLERK OF THE CIRCUIT COURT
 ARCHIVES AND RECORDS
 CHILDSUPPORT
 CIRCUIT CIVIL
 CIRCUIT CRIMINAL
 COUNTY CIVIL
 COUNTY CRIMINAL
 DOMESTIC RELATIONS
 FAMILY LAW
 JURY ASSEMBLY
 JUVENILE
 MENTAL HEALTH
 MIS
 OPERATIONAL SERVICES
 PROBATE
 TRAFFIC



BRANCH OFFICES
ARCHIVES AND RECORDS
JUVENILE DIVISION
CENTURY

CLERK TO THE BOARD OF
 COUNTY COMMISSIONERS
 OFFICIAL RECORDS
 COUNTY TREASURY
 AUDITOR

COUNTY OF ESCAMBIA
OFFICE OF THE
CLERK OF THE CIRCUIT COURT

Case # 2018 TD 003996

Redeemed Date 09/15/2021

Name BILLY C GOLDING JR 120 RUE MAX AVE PENSACOLA, FL 32507

Clerk's Total = TAXDEED	\$558.07
Due Tax Collector = TAXDEED	\$1,840.85
Postage = TD2	\$24.00
ResearcherCopies = TD6	\$0.00
Release TDA Notice (Recording) = RECORD2	\$10.00
Release TDA Notice (Prep Fee) = TD4	\$7.00

• For Office Use Only

Date	Docket	Desc	Amount Owed	Amount Due	Payee Name
------	--------	------	-------------	------------	------------

FINANCIAL SUMMARY

No Information Available - See Dockets

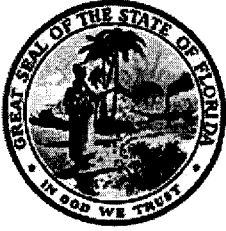

PAM CHILDERS
CLERK OF THE CIRCUIT COURT
ESCAMBIA COUNTY, FLORIDA

Tax Deed - Redemption Calculator
Account: 080678000 Certificate Number: 003996 of 2018

Redemption Yes No
 Application Date
 Interest Rate

	Final Redemption Payment ESTIMATED	Redemption Overpayment ACTUAL
	Auction Date <input type="text" value="10/04/2021"/>	Redemption Date <input type="text" value="09/15/2021"/>
Months	13	12
Tax Collector	<input type="text" value="\$1,535.23"/>	<input type="text" value="\$1,535.23"/>
Tax Collector Interest	\$299.37	\$276.34
Tax Collector Fee	<input type="text" value="\$6.25"/>	<input type="text" value="\$6.25"/>
Total Tax Collector	\$1,840.85	<input type="text" value="\$1,817.82"/> TC
Record TDA Notice	<input type="text" value="\$17.00"/>	<input type="text" value="\$17.00"/>
Clerk Fee	<input type="text" value="\$130.00"/>	<input type="text" value="\$130.00"/>
Sheriff Fee	<input type="text" value="\$120.00"/>	<input type="text" value="\$120.00"/>
Legal Advertisement	<input type="text" value="\$200.00"/>	<input type="text" value="\$200.00"/>
App. Fee Interest	\$91.07	\$84.06
Total Clerk	\$558.07	<input type="text" value="\$551.06"/> CH
Release TDA Notice (Recording)	<input type="text" value="\$10.00"/>	<input type="text" value="\$10.00"/>
Release TDA Notice (Prep Fee)	<input type="text" value="\$7.00"/>	<input type="text" value="\$7.00"/>
Postage	<input type="text" value="\$24.00"/>	<input type="text" value="\$24.00"/>
Researcher Copies	<input type="text" value="\$0.00"/>	<input type="text" value="\$0.00"/>
Total Redemption Amount	\$2,439.92	\$2,409.88
	Repayment Overpayment Refund Amount	\$30.04
Book/Page	<input type="text" value="8410"/>	<input type="text" value="432"/>

RELEASE OF NOTICE OF APPLICATION FOR TAX DEED

Pursuant to § 197.502(5)(c), Florida Statutes, the Escambia County Clerk of Court fully releases the Notice of Tax Deed Application recorded at Official Records Book 8410, Page 432, of Escambia County, for the tax certificate, tax deed, and property described below:

Tax Certificate No. Certificate No. 03996, issued the 1st day of June, A.D., 2018

TAX ACCOUNT NUMBER: **080678000 (1021-14)**

DESCRIPTION OF PROPERTY:

**LT 18 BLK 29 OR 3991 P 495 RE S/D OF BLK B 2ND ADDN TO AERO VISTA PB 2 P 81/81A CA
196**

SECTION 50, TOWNSHIP 2 S, RANGE 30 W

NAME IN WHICH ASSESSED: BILLY C GOLDING JR and AUGUSTA L GOLDING

Dated this 15th day of September 2021.



PAM CHILDERS
CLERK OF THE CIRCUIT COURT
ESCAMBIA COUNTY, FLORIDA

By:
Emily Hogg
Deputy Clerk

ESCAMBIA COUNTY SHERIFF'S OFFICE
ESCAMBIA COUNTY, FLORIDA

NON-ENFORCEABLE RETURN OF SERVICE

1021-14

Document Number: ECSO21CIV029475NON

Agency Number: 21-009248

Court: TAX DEED

County: ESCAMBIA

Case Number: CERT NO 03996 2018

Attorney/Agent:

PAM CHILDERS
CLERK OF COURT
TAX DEED

undelivered

Plaintiff: IN RE BILLY C GOLDING JR AND AUGUSTA L GOLDING

Defendant:

Type of Process: NOTICE OF APPLICATION FOR TAX DEED

Received this Writ on 8/20/2021 at 9:39 AM and served same at 9:32 AM on 8/24/2021 in ESCAMBIA COUNTY, FLORIDA, by serving POST PROPERTY , the within named, to wit: , .

POSTED TO PROPERTY PER CLERKS OFFICE INSTRUCTIONS

CHIP W SIMMONS, SHERIFF
ESCAMBIA COUNTY, FLORIDA

By: _____

L. Littlejohn 9/20

L. LITTLEJOHN, CPS

Service Fee: \$40.00

Receipt No: BILL

WARNING

THERE ARE UNPAID TAXES ON PROPERTY WHICH YOU OWN OR IN WHICH YOU HAVE A LEGAL INTEREST. THE PROPERTY WILL BE SOLD AT PUBLIC AUCTION ON October 4, 2021, UNLESS THE TAXES ARE PAID. SHOULD YOU NEED FURTHER INFORMATION CONTACT THE CLERK OF THE CIRCUIT COURT IMMEDIATELY AT THE COUNTY COURTHOUSE IN PENSACOLA, FLORIDA, OR CALL 850-595-3793.

NOTICE OF APPLICATION FOR TAX DEED

NOTICE IS HEREBY GIVEN, That MIKON FINANCIAL SERVICES INC AND OCEAN BANK holder of Tax Certificate No. 03996, issued the 1st day of June, A.D., 2018 has filed same in my office and has made application for a tax deed to be issued thereon. Said certificate embraces the following described property in the County of Escambia, State of Florida, to wit:

LT 18 BLK 29 OR 3991 P 495 RE S/D OF BLK B 2ND ADDN TO AERO VISTA PB 2 P 81/81A CA 196

SECTION 50, TOWNSHIP 2 S, RANGE 30 W

TAX ACCOUNT NUMBER 080678000 (1021-14)

The assessment of the said property under the said certificate issued was in the name of

BILLY C GOLDING JR and AUGUSTA L GOLDING

Unless said certificate shall be redeemed according to law, the property described therein will be sold to the highest bidder at public auction at 9:00 A.M. on the first Monday in the month of October, which is the 4th day of October 2021.

Dated this 17th day of August 2021.

In accordance with the AMERICANS WITH DISABILITIES ACT, if you are a person with a disability who needs special accommodation in order to participate in this proceeding you are entitled to the provision of certain assistance. Please contact Emily Hogg not later than seven days prior to the proceeding at Escambia County Government Complex, 221 Palafox Place Ste 110, Pensacola FL 32502. Telephone: 850-595-3793.

Post Property:

120 RUE MAX AVE 32507



PAM CHILDERS
CLERK OF THE CIRCUIT COURT
ESCAMBIA COUNTY, FLORIDA

By:
Emily Hogg
Deputy Clerk

ESCAMBIA COUNTY SHERIFF'S OFFICE
ESCAMBIA COUNTY, FLORIDA

NON-ENFORCEABLE RETURN OF SERVICE

1021-14

Document Number: ECSO21CIV029478NON

Agency Number: 21-009249

Court: TAX DEED

County: ESCAMBIA

Case Number: CERT NO 03996 2018

Attorney/Agent:

PAM CHILDERS
CLERK OF COURT
TAX DEED

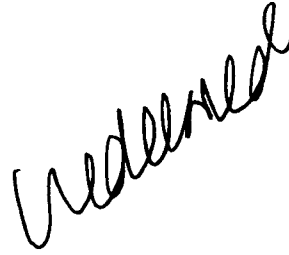

Plaintiff: IN RE BILLY C GOLDING JR AND AUGUSTA L GOLDING

Defendant:

Type of Process: NOTICE OF APPLICATION FOR TAX DEED

Substitute

Received this Writ on 8/20/2021 at 9:39 AM and served same on BILLY C GOLDING JR , in ESCAMBIA COUNTY, FLORIDA, at 9:32 AM on 8/24/2021 by leaving a true copy of this Writ together with a copy of the initial pleadings, if any, with the date and hour of service endorsed thereon by me, at the within named individual's usual place of abode, with a person residing therein who is 15 years of age, or older, to wit: AUGUSTA GOLDING, WIFE, as a member of the household and informing said person of their contents.

CHIP W SIMMONS, SHERIFF
ESCAMBIA COUNTY, FLORIDA

By: _____

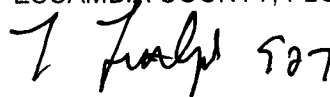

L. LITTLEJOHN, CPS

Service Fee: \$40.00
Receipt No: BILL

Printed By: GBGUY

08/17/21

WARNING

THERE ARE UNPAID TAXES ON PROPERTY WHICH YOU OWN OR IN WHICH YOU HAVE A LEGAL INTEREST. THE PROPERTY WILL BE SOLD AT PUBLIC AUCTION ON October 4, 2021, UNLESS THE TAXES ARE PAID. SHOULD YOU NEED FURTHER INFORMATION CONTACT THE CLERK OF THE CIRCUIT COURT IMMEDIATELY AT THE COUNTY COURTHOUSE IN PENSACOLA, FLORIDA, OR CALL 850-595-3793.

NOTICE OF APPLICATION FOR TAX DEED

NOTICE IS HEREBY GIVEN, That **MIKON FINANCIAL SERVICES INC AND OCEAN BANK** holder of **Tax Certificate No. 03996**, issued the **1st day of June, A.D., 2018** has filed same in my office and has made application for a tax deed to be issued thereon. Said certificate embraces the following described property in the County of Escambia, State of Florida, to wit:

LT 18 BLK 29 OR 3991 P 495 RE S/D OF BLK B 2ND ADDN TO AERO VISTA PB 2 P 81/81A CA 196

SECTION 50, TOWNSHIP 2 S, RANGE 30 W

TAX ACCOUNT NUMBER 080678000 (1021-14)

The assessment of the said property under the said certificate issued was in the name of

BILLY C GOLDING JR and AUGUSTA L GOLDING

Unless said certificate shall be redeemed according to law, the property described therein will be sold to the highest bidder at public auction at 9:00 A.M. on the **first** Monday in the month of October, which is the **4th day of October 2021**.

Dated this 17th day of August 2021.

In accordance with the AMERICANS WITH DISABILITIES ACT, if you are a person with a disability who needs special accommodation in order to participate in this proceeding you are entitled to the provision of certain assistance. Please contact Emily Hogg not later than seven days prior to the proceeding at Escambia County Government Complex, 221 Palafox Place Ste 110, Pensacola FL 32502. Telephone: 850-595-3793.

Personal Services:

BILLY C GOLDING JR
120 RUE MAX AVE
PENSACOLA, FL 32507

PAM CHILDERS
CLERK OF THE CIRCUIT COURT
ESCAMBIA COUNTY, FLORIDA



By:
Emily Hogg
Deputy Clerk

ESCAMBIA COUNTY SHERIFF'S OFFICE
ESCAMBIA COUNTY, FLORIDA

NON-ENFORCEABLE RETURN OF SERVICE

1021-14

Document Number: ECSO21CIV029480NON

Agency Number: 21-009250

Court: TAX DEED

County: ESCAMBIA

Case Number: CERT NO 03996

Attorney/Agent:

PAM CHILDERS
CLERK OF COURT
TAX DEED

Weddell

Plaintiff: IN RE BILLY C GOLDING JR AND AUGUSTA L GOLDING

Defendant:

Type of Process: NOTICE OF APPLICATION FOR TAX DEED

Individual

Received this Writ on 8/20/2021 at 9:39 AM and served same on AUGUSTA L GOLDING , at 9:32 AM on 8/24/2021 in ESCAMBIA COUNTY, FLORIDA, by delivering a true copy of this Writ together with a copy of the initial pleadings, if any, with the date and hour of service endorsed thereon by me.

CHIP W SIMMONS, SHERIFF
ESCAMBIA COUNTY, FLORIDA

By: *L. Littlejohn*
L. LITTLEJOHN, CPS

Service Fee: \$40.00
Receipt No: BILL

WARNING

THERE ARE UNPAID TAXES ON PROPERTY WHICH YOU OWN OR IN WHICH YOU HAVE A LEGAL INTEREST. THE PROPERTY WILL BE SOLD AT PUBLIC AUCTION ON October 4, 2021, UNLESS THE TAXES ARE PAID. SHOULD YOU NEED FURTHER INFORMATION CONTACT THE CLERK OF THE CIRCUIT COURT IMMEDIATELY AT THE COUNTY COURTHOUSE IN PENSACOLA, FLORIDA, OR CALL 850-595-3793.

NOTICE OF APPLICATION FOR TAX DEED

NOTICE IS HEREBY GIVEN, That **MIKON FINANCIAL SERVICES INC AND OCEAN BANK** holder of **Tax Certificate No. 03996**, issued the **1st day of June, A.D., 2018** has filed same in my office and has made application for a tax deed to be issued thereon. Said certificate embraces the following described property in the County of Escambia, State of Florida, to wit:

LT 18 BLK 29 OR 3991 P 495 RE S/D OF BLK B 2ND ADDN TO AERO VISTA PB 2 P 81/81A CA 196

SECTION 50, TOWNSHIP 2 S, RANGE 30 W

TAX ACCOUNT NUMBER 080678000 (1021-14)

The assessment of the said property under the said certificate issued was in the name of

BILLY C GOLDING JR and AUGUSTA L GOLDING

Unless said certificate shall be redeemed according to law, the property described therein will be sold to the highest bidder at public auction at 9:00 A.M. on the **first** Monday in the month of October, which is the **4th day of October 2021**.

Dated this 17th day of August 2021.

In accordance with the AMERICANS WITH DISABILITIES ACT, if you are a person with a disability who needs special accommodation in order to participate in this proceeding you are entitled to the provision of certain assistance. Please contact Emily Hogg not later than seven days prior to the proceeding at Escambia County Government Complex, 221 Palafox Place Ste 110, Pensacola FL 32502. Telephone: 850-595-3793.

Personal Services:

AUGUSTA L GOLDING
120 RUE MAX AVE
PENSACOLA, FL 32507

PAM CHILDERS
CLERK OF THE CIRCUIT COURT
ESCAMBIA COUNTY, FLORIDA



By:
Emily Hogg
Deputy Clerk

BILLY C GOLDING JR [1021-14]
120 RUE MAX AVE
PENSACOLA, FL 32507

9171 9690 0935 0127 1512 93

AUGUSTA L GOLDING [1021-14]
120 RUE MAX AVE
PENSACOLA, FL 32507

9171 9690 0935 0127 1513 09

ESCAMBIA COUNTY / COUNTY
ATTORNEY [1021-14]
221 PALAFOX PLACE STE 430
PENSACOLA FL 32502

9171 9690 0935 0127 1513 16

NEIGHBORHOOD ENTERPRISE
DIVISION [1021-14]
PO BOX 18178
PENSACOLA, FL 32523

9171 9690 0935 0127 1513 23

Redeemed

Pam Childers
Clerk of the Circuit Court & Comptroller
Official Records
221 Palafox Place, Suite 110
Pensacola, FL 32502

CERTIFIED MAIL™

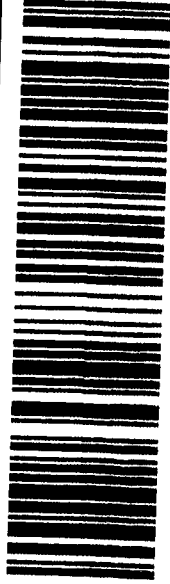

9171 9690 0935 0127 1513 23

quadrant

FIRST-CLASS MAIL

\$005.86⁰

08/19/2021 ZIP 32502
043431703251

US POSTAGE

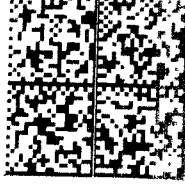

NEIGHBORHOOD ENTERPRISE
DIVISION [1021-14]
PO BOX 18178
PENSACOLA, FL 32523

VAC

BC: 32502563335

*2187-04815-20-45

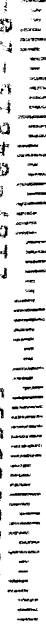
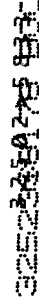

323 DE 1 0009/02/21

RETURN TO SENDER

VACANT

UNABLE TO FORWARD

[Handwritten signature]

[Handwritten initials]

THE SUMMATION WEEKLY

A Weekly Publication of the Escambia-Santa Rosa Bar Association Since 2014

NOTICE OF APPLICATION FOR TAX DEED

NOTICE IS HEREBY GIVEN, That MIKON FINANCIAL SERVICES INC AND OCEAN BANK holder of Tax Certificate No. 03996, issued the 1st day of June, A.D., 2018 has filed same in my office and has made application for a tax deed to be issued thereon. Said certificate embraces the following described property in the County of Escambia, State of Florida, to wit:

LT 18 BLK 29 OR 3991 P 495 RE S/D OF BLK B 2ND ADDN TO AERO VISTA PB 2 P 81/81A CA 196

SECTION 50, TOWNSHIP 2 S, RANGE 30 W
TAX ACCOUNT NUMBER 080678000 (1021-14)
The assessment of the said property under the said certificate issued was in the name of

BILLY C GOLDING JR and AUGUSTA L GOLDING

Unless said certificate shall be redeemed according to law, the property described therein will be sold to the highest bidder at public auction at 9:00 A.M. on the first Monday in the month of October, which is the 4th day of October 2021

Dated this 19th day of August 2021.

In accordance with the AMERICANS WITH DISABILITIES ACT, if you are a person with a disability who needs special accommodation in order to participate in this proceeding you are entitled to the provision of certain assistance. Please contact Emily Hogg not later than seven days prior to the proceeding at Escambia County Government Complex, 221 Palafox Place Ste 110, Pensacola FL 32502. Telephone: 850-595-3793.

PAM CHILDERS
CLERK OF THE CIRCUIT COURT
ESCAMBIA COUNTY, FLORIDA

By:
Emily Hogg
Deputy Clerk

4WR9/1-9/22TD

Before the undersigned authority personally appeared Bridget Roberts who under oath says that she is the Legal Administrator and Publisher of The Summation Weekly Newspaper published at Pensacola in Escambia & Santa Rosa County, Florida; that the attached copy of the advertisement, being a notice in the matter of **2018 TD 03996** in the Escambia County Court was published in said newspaper in and was printed and released on September 1, 2021, September 8, 2021, September 15, 2021, September 22, 2021.

Affiant further says that the said Summation Weekly is a newspaper published at Pensacola, in said Escambia & Santa Rosa Counties, Florida, and that the said newspaper has heretofore been continuously published in said Escambia & Santa Rosa Counties, Florida each week and has been entered as second class mail matter at the post office in Pensacola, in said Escambia County, Florida, for a period of one year next preceding the first publication of the attached copy of advertisement; and affiant further says that he has neither paid nor promised any person, firm or corporation any discount, rebate, commission or refund for the purpose of securing this advertisement for publication of the said newspaper.

X

BRIDGET ROBERTS, LEGAL ADMINISTRATOR FOR
THE SUMMATION WEEKLY

STATE OF FLORIDA
COUNTY OF ESCAMBIA

The foregoing instrument was acknowledged before me by means of physical presence or online notarization, this 23rd day of September, 2021, by BRIDGET ROBERTS, who is personally known to me.

X

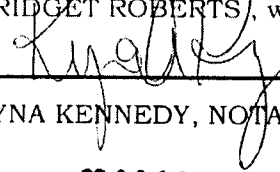
KYNA KENNEDY, NOTARY PUBLIC

