

CERTIFICATION OF TAX DEED APPLICATION

Sections 197.502 and 197.542, Florida Statutes

0421-42

513
R. 07/19

Part 1: Tax Deed Application Information			
Applicant Name Applicant Address	TLOA OF FLORIDA LLC CAPITOL ONE BANK, C/O TLOA HOLDINGS, LLC PO BOX 54077 NEW ORLEANS, LA 70154-4077	Application date	Apr 21, 2020
Property description	PITMAN JERRY TRUSTEE FOR TRUST IN THE LAST WILL & TESTAMENT C/O LYNE PITMAN 301 N PINWOOD LN PENSACOLA, FL 32507 301 N PINWOOD LN BEG AT INTER OF W LI OF 1ST ST AND N LI OF THIRD AVE NLY 360 FT FOR POB W 60 FT N TO BAYOU ELY ALG B (Full legal attached.)	Certificate #	2018 / 3941
		Date certificate issued	06/01/2018
		Deed application number	2000396
		Account number	07-4448-050

Part 2: Certificates Owned by Applicant and Filed with Tax Deed Application				
Column 1 Certificate Number	Column 2 Date of Certificate Sale	Column 3 Face Amount of Certificate	Column 4 Interest	Column 5: Total (Column 3 + Column 4)
# 2018/3941	06/01/2018	1,296.69	64.83	1,361.52
→Part 2: Total*				1,361.52

Part 3: Other Certificates Redeemed by Applicant (Other than County)					
Column 1 Certificate Number	Column 2 Date of Other Certificate Sale	Column 3 Face Amount of Other Certificate	Column 4 Tax Collector's Fee	Column 5 Interest	Total (Column 3 + Column 4 + Column 5)
# 2019/3727	06/01/2019	1,303.57	6.25	65.18	1,375.00
Part 3: Total*					1,375.00

Part 4: Tax Collector Certified Amounts (Lines 1-7)	
1. Cost of all certificates in applicant's possession and other certificates redeemed by applicant (*Total of Parts 2 + 3 above)	2,736.52
2. Delinquent taxes paid by the applicant	0.00
3. Current taxes paid by the applicant	1,200.27
4. Property information report fee and Deed Application Recording and Release Fees	200.00
5. Tax deed application fee	175.00
6. Interest accrued by tax collector under s.197.542, F.S. (see Tax Collector Instructions, page 2)	0.00
7. Total Paid (Lines 1-6)	4,311.79

I certify the above information is true and the tax certificates, interest, property information report fee, and tax collector's fees have been paid, and that the property information statement is attached.

Sign here: _____ Escambia County, Florida
Signature, Tax Collector or Designee Date May 4th, 2020

Send this certification to the Clerk of Court by 10 days after the date signed. See Instructions on Page 2

Part 5: Clerk of Court Certified Amounts (Lines 8-14)	
8. Processing tax deed fee	
9. Certified or registered mail charge	
10. Clerk of Court advertising, notice for newspaper, and electronic auction fees	
11. Recording fee for certificate of notice	
12. Sheriff's fees	
13. Interest (see Clerk of Court Instructions, page 2)	
14. Total Paid (Lines 8-13)	
15. Plus one-half of the assessed value of homestead property, if applicable under s. 197.502(6)(c), F.S.	57356
16. Other outstanding certificates and delinquent taxes not included in this Application, if applicable per Florida statutes	
17. Statutory opening bid (total of Lines 7, 14, 15, and 16 if applicable)	
18. Redemption fee	6.25
19. Total amount to redeem	
Sign here: _____ Date of sale <u>4-5-21</u>	
Signature, Clerk of Court or Designee	

INSTRUCTIONS

Tax Collector (complete Parts 1-4)

Part 2: Certificates Owned by Applicant and Filed with Tax Deed Application

Enter the Face Amount of Certificate in Column 3 and the Interest in Column 4 for each certificate number. Add Columns 3 and 4 and enter the amount in Column 5.

Part 3: Other Certificates Redeemed by Applicant (Other than County)

Total. Add the amounts in Columns 3, 4 and 5

Part 4: Tax Collector Certified Amounts (Lines 1-7)

Line 1, enter the total of Part 2 plus the total of Part 3 above.

Total Paid, Line 7: Add the amounts of Lines 1-6

Line 6, Interest accrued by tax collector. Calculate the 1.5 percent interest accrued from the month after the date of application through the month this form is certified to the clerk. Enter the amount to be certified to the clerk on **Line 6**. The interest calculated by the tax collector stops before the interest calculated by the clerk begins. See Section 197.542, F.S., and Rule 12D-13.060(3), Florida Administrative Code.

The tax collector's interest for redemption at the time of the tax deed application is a cost of redemption, which encompasses various percentages of interest on certificates and omitted or delinquent taxes under Section 197.502, F.S. This interest is calculated before the tax collector calculates the interest in Section 197.542, F.S.

Attach certified statement of names and addresses of persons who must be notified before the sale of the property. Send this form and any required attachments to the Clerk of Court within 10 days after it is signed.

Clerk of Court (complete Part 5)

Line 13: Interest is calculated at the rate of 1.5 percent per month starting from the first day of the month after the month of certification of this form through the last day of the month in which the sale will be held. Multiply the calculated rate by the total of **Line 7**, minus **Line 6**, plus **Lines 8 through 12**. Enter the amount on **Line 13**.

Line 14: Enter the total of Lines 8-13. Complete Lines 15-18, if applicable.

BEG AT INTER OF W LI OF 1ST ST AND N LI OF THIRD AVE NLY 360 FT FOR POB W 60 FT N TO BAYOU ELY ALG BAYOU TO W LI OF 1ST ST SLY ALG 1ST ST 230 FT TO POB LT 1 BLK 17 OF AN UNRECORDED PLAT OR 6314 P 867 CASE # 2006 CP 2295 CA 160

APPLICATION FOR TAX DEED

Section 197.502, Florida Statutes

512
R. 12/16

Application Number: 2000396

To: Tax Collector of ESCAMBIA COUNTY, Florida

I,
TLOA OF FLORIDA LLC
CAPITOL ONE BANK, C/O TLOA HOLDINGS, LLC PO BOX 54077
NEW ORLEANS, LA 70154-4077,

hold the listed tax certificate and hereby surrender the same to the Tax Collector and make tax deed application thereon:

Account Number	Certificate No.	Date	Legal Description
07-4448-050	2018/3941	06-01-2018	BEG AT INTER OF W LI OF 1ST ST AND N LI OF THIRD AVE NLY 360 FT FOR POB W 60 FT N TO BAYOU ELY ALG BAYOU TO W LI OF 1ST ST SLY ALG 1ST ST 230 FT TO POB LT 1 BLK 17 OF AN UNRECORDED PLAT OR 6314 P 867 CASE # 2006 CP 2295 CA 160

I agree to:

- pay any current taxes, if due and
- redeem all outstanding tax certificates plus interest not in my possession, and
- pay all delinquent and omitted taxes, plus interest covering the property.
- pay all Tax Collector's fees, property information report costs, Clerk of the Court costs, charges and fees, and Sheriff's costs, if applicable.

Attached is the tax sale certificate on which this application is based and all other certificates of the same legal description which are in my possession.

Electronic signature on file
TLOA OF FLORIDA LLC
CAPITOL ONE BANK, C/O TLOA HOLDINGS, LLC PO
BOX 54077
NEW ORLEANS, LA 70154-4077

04-21-2020
Application Date

Applicant's signature



Chris Jones Escambia County Property Appraiser

Real Estate Search | Tangible Property Search | Sale List

← Navigate Mode Account Reference →

[Printer Friendly Version](#)

General Information

Reference: 382S301001010017
Account: 074448050
Owners: PITMAN JERRY TRUSTEE
 FOR TRUST IN THE LAST WILL &
 TESTAMENT
 OF ELMER W PTIMAN JR
Mail: C/O LYNE PITMAN
 301 N PINWOOD LN
 PENSACOLA, FL 32507
Situs: 301 N PINWOOD LN 32507
Use Code: SINGLE FAMILY RESID
Taxing Authority: COUNTY MSTU
Tax Inquiry: [Open Tax Inquiry Window](#)
 Tax Inquiry link courtesy of Scott Lunsford
 Escambia County Tax Collector

Assessments

Year	Land	Imprv	Total	Cap Val
2019	\$42,720	\$86,230	\$128,950	\$114,712
2018	\$42,720	\$80,548	\$123,268	\$112,574
2017	\$42,720	\$75,164	\$117,884	\$110,259

Disclaimer

Tax Estimator

> **File for New Homestead Exemption Online**

Sales Data

Sale Date	Book	Page	Value	Type	Official Records (New Window)
04/01/2008	6314	867	\$100	CJ	View Instr
01/1975	897	192	\$100	WD	View Instr
01/1972	646	540	\$13,200	WD	View Instr
01/1971	523	797	\$13,100	WD	View Instr
01/1969	428	773	\$13,000	WD	View Instr

Official Records Inquiry courtesy of Pam Childers
 Escambia County Clerk of the Circuit Court and
 Comptroller

2019 Certified Roll Exemptions

HOMESTEAD EXEMPTION

Legal Description

BEG AT INTER OF W LI OF 1ST ST AND N LI OF THIRD
 AVE NLY 360 FT FOR POB W 60 FT N TO BAYOU ELY
 ALG BAYOU TO W LI...

Extra Features

BOAT DOCK
 BOAT HOUSE
 FRAME BUILDING
 FRAME SHED
 METAL SHED

Parcel Information [Launch Interactive Map](#)

Section Map Id:
[CA160](#)

Approx. Acreage:
 0.3249

Zoned:
 MDR

Evacuation & Flood Information
[Open Report](#)

[View Florida Department of Environmental Protection\(DEP\) Data](#)

Buildings

Address:301 N PINWOOD LN, Year Built: 1952, Effective Year: 1965

Structural Elements	
DECOR/MILLWORK-AVERAGE	

DWELLING UNITS-1
EXTERIOR WALL-CONCRETE BLOCK
FLOOR COVER-CARPET
FOUNDATION-SLAB ON GRADE
HEAT/AIR-CENTRAL H/AC
INTERIOR WALL-DRYWALL-PLASTER
INTERIOR WALL-PANEL-PLYWOOD
NO. PLUMBING FIXTURES-6
NO. STORIES-1
ROOF COVER-COMPOSITION SHG
ROOF FRAMING-GABL/HIP COMBO
STORY HEIGHT-0
STRUCTURAL FRAME-MASONRY
PIL/STL

 Areas - 2747 Total SF

BASE AREA - 2059
CARPORT UNF - 380
OPEN PORCH FIN - 308

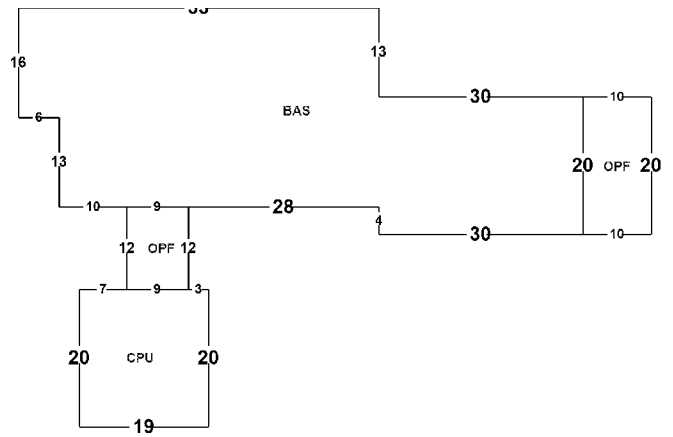

Images



6/23/16

The primary use of the assessment data is for the preparation of the current year tax roll. No responsibility or liability is assumed for inaccuracies or errors.

Last Updated:05/08/2020 (tc.3634)

NOTICE OF APPLICATION FOR TAX DEED

NOTICE IS HEREBY GIVEN, That **TLOA OF FLORIDA LLC CAPITOL ONE BANK C/O TLOA HOLDINGS LLC** holder of **Tax Certificate No. 03941**, issued the **1st day of June, A.D., 2018** has filed same in my office and has made application for a tax deed to be issued thereon. Said certificate embraces the following described property in the County of Escambia, State of Florida, to wit:

BEG AT INTER OF W LI OF 1ST ST AND N LI OF THIRD AVE NLY 360 FT FOR POB W 60 FT N TO BAYOU ELY ALG BAYOU TO W LI OF 1ST ST SLY ALG 1ST ST 230 FT TO POB LT 1 BLK 17 OF AN UNRECORDED PLAT OR 6314 P 867 CASE # 2006 CP 2295 CA 160

SECTION 38, TOWNSHIP 2 S, RANGE 30 W

TAX ACCOUNT NUMBER 074448050 (0421-42)

The assessment of the said property under the said certificate issued was in the name of

JERRY PITMAN TRUSTEE and ELMER W PITMAN JR TRUST

Unless said certificate shall be redeemed according to law, the property described therein will be sold to the highest bidder at public auction at 9:00 A.M. on the **first Monday** in the month of **April**, which is the **5th day of April 2021**.

Dated this 12th day of May 2020.

In accordance with the AMERICANS WITH DISABILITIES ACT, if you are a person with a disability who needs special accommodation in order to participate in this proceeding you are entitled to the provision of certain assistance. Please contact Emily Hogg not later than seven days prior to the proceeding at Escambia County Government Complex, 221 Palafox Place Ste 110, Pensacola FL 32502. Telephone: 850-595-3793.

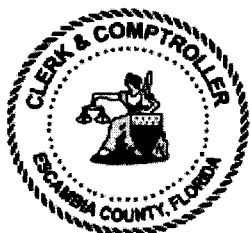

PAM CHILDERS
CLERK OF THE CIRCUIT COURT
ESCAMBIA COUNTY, FLORIDA

By:
Emily Hogg
Deputy Clerk



CERTIFICATION OF TAX DEED APPLICATION

Sections 197.502 and 197.542, Florida Statutes

DR-513
Rule 12D-16.002 F.A.C
Effective 07/19
Page 1 of 2

Part 1: Tax Deed Application Information

Applicant Name	TLOA OF FLORIDA LLC	Application date	Apr 21, 2020
Applicant Address	CAPITOL ONE BANK, C/O TLOA HOLDINGS, LLC PO BOX 54077 NEW ORLEANS, LA 70154-4077		
Property description	PITMAN JERRY TRUSTEE FOR TRUST IN THE LAST WILL & TESTAMENT C/O LYNE PITMAN 301 N PINWOOD LN PENSACOLA, FL 32507 301 N PINWOOD LN 07-4448-050 BEG AT INTER OF W LI OF 1ST ST AND N LI OF THIRD AVE NLY 360 FT FOR POB W 60 FT N TO BAYOU ELY ALG B (Full legal attached.)	Certificate #	2018 / 3941
		Date certificate issued	06/01/2018

Part 2: Certificates Owned by Applicant and Filed with Tax Deed Application

Column 1 Certificate Number	Column 2 Date of Certificate Sale	Column 3 Face Amount of Certificate	Column 4 Interest	Column 5: Total (Column 3 + Column 4)
# 2018/3941	06/01/2018	1,296.69	64.83	1,361.52
→Part 2: Total*				1,361.52

Part 3: Other Certificates Redeemed by Applicant (Other than County)

Column 1 Certificate Number	Column 2 Date of Other Certificate Sale	Column 3 Face Amount of Other Certificate	Column 4 Tax Collector's Fee	Column 5 Interest	Total (Column 3 + Column 4 + Column 5)
# 2019/3727	06/01/2019	1,303.57	6.25	65.18	1,375.00
Part 3: Total*					1,375.00

Part 4: Tax Collector Certified Amounts (Lines 1-7)

1. Cost of all certificates in applicant's possession and other certificates redeemed by applicant (*Total of Parts 2 + 3 above)	2,736.52
2. Delinquent taxes paid by the applicant	0.00
3. Current taxes paid by the applicant	1,200.27
4. Property information report fee	200.00
5. Tax deed application fee	175.00
6. Interest accrued by tax collector under s.197.542, F.S. (see Tax Collector Instructions, page 2)	0.00
7. Total Paid (Lines 1-6)	4,311.79

I certify the above information is true and the tax certificates, interest, property information report fee, and tax collector's fees have been paid, and that the property information statement is attached.

Sign here: Escambia, Florida
 Signature, Tax Collector or Designee Date July 31st, 2020

Send this certification to the Clerk of Court by 10 days after the date signed. See Instructions on Page 2

Part 5: Clerk of Court Certified Amounts (Lines 8-14)	
8. Processing tax deed fee	
9. Certified or registered mail charge	
10. Clerk of Court advertising, notice for newspaper, and electronic auction fees	
11. Recording fee for certificate of notice	
12. Sheriff's fees	
13. Interest (see Clerk of Court Instructions, page 2)	
14. Total Paid (Lines 8-13)	
15. Plus one-half of the assessed value of homestead property, if applicable under s. 197.502(6)(c), F.S.	57,356.00
16. Statutory opening bid (total of Lines 7, 14, 15, and 16 if applicable)	
Sign here: _____ Date of sale <u>04/05/2021</u>	
Signature, Clerk of Court or Designee	

INSTRUCTIONS *+ 6.25*

Tax Collector (complete Parts 1-4)

Part 2: Certificates Owned by Applicant and Filed with Tax Deed Application
 Enter the Face Amount of Certificate in Column 3 and the Interest in Column 4 for each certificate number. Add Columns 3 and 4 and enter the amount in Column 5.

Part 3: Other Certificates Redeemed by Applicant (Other than County)
Total. Add the amounts in Columns 3, 4 and 5

Part 4: Tax Collector Certified Amounts (Lines 1-7)

Line 1, enter the total of Part 2 plus the total of Part 3 above.

Total Paid, Line 7: Add the amounts of Lines 1-6

Line 6, Interest accrued by tax collector. Calculate the 1.5 percent interest accrued from the month after the date of application through the month this form is certified to the clerk. Enter the amount to be certified to the clerk on Line 6. The interest calculated by the tax collector stops before the interest calculated by the clerk begins. See Section 197.542, F.S., and Rule 12D-13.060(3), Florida Administrative Code.

The tax collector's interest for redemption at the time of the tax deed application is a cost of redemption, which encompasses various percentages of interest on certificates and omitted or delinquent taxes under Section 197.502, F.S. This interest is calculated before the tax collector calculates the interest in Section 197.542, F.S.

Attach certified statement of names and addresses of persons who must be notified before the sale of the property. Send this form and any required attachments to the Clerk of Court within 10 days after it is signed.

Clerk of Court (complete Part 5)

Line 13: Interest is calculated at the rate of 1.5 percent per month starting from the first day of the month after the month of certification of this form through the last day of the month in which the sale will be held. Multiply the calculated rate by the total of Line 7, minus Line 6, plus Lines 8 through 12. Enter the amount on Line 13.

Line 14: Enter the total of Lines 8-13. Complete Lines 15-18, if applicable.

BEG AT INTER OF W LI OF 1ST ST AND N LI OF THIRD AVE NLY 360 FT FOR POB W 60 FT N TO BAYOU ELY ALG BAYOU TO W LI OF 1ST ST SLY ALG 1ST ST 230 FT TO POB LT 1 BLK 17 OF AN UNRECORDED PLAT OR 6314 P 867 CASE # 2006 CP 2295 CA 160



PROPERTY INFORMATION REPORT
3050 Concho Drive, Pensacola, Florida 32507 | Phone: 850-466-3077

THE ATTACHED REPORT IS ISSUED TO:

SCOTT LUNSFORD, ESCAMBIA COUNTY TAX COLLECTOR

TAX ACCOUNT #: 07-4448-050 CERTIFICATE #: 2018-3941

THIS REPORT IS NOT TITLE INSURANCE. THE LIABILITY FOR ERRORS OR OMISSIONS IN THIS REPORT IS LIMITED TO THE PERSON(S) EXPRESSLY IDENTIFIED BY NAME IN THE PROPERTY INFORMATION REPORT AS THE RECIPIENT(S) OF THE PROPERTY INFORMATION REPORT.

The attached Report prepared in accordance with the instructions given by the user named above includes a listing of the owner(s) of record of the land described herein together with current and delinquent ad valorem tax information and a listing and copies of all open or unsatisfied leases, mortgages, judgments and encumbrances recorded in the Official Record Books of Escambia County, Florida that appear to encumber the title to said land as listed on page 2 herein. It is the responsibility of the party named above to verify receipt of each document listed. If a copy of any document listed is not received, the office issuing this Report must be contacted immediately.

This Report is subject to: Current year taxes; taxes and assessments due now or in subsequent years; oil, gas, and mineral or any subsurface rights of any kind or nature; easements, restrictions and covenants of record; encroachments, overlaps, boundary line disputes, and any other matters that would be disclosed by an accurate survey and inspection of the premises.

This Report does not insure or guarantee the validity or sufficiency of any document attached, nor is it to be considered a title insurance policy, an opinion of title, a guarantee of title, or as any other form of guarantee or warranty of title.

Use of the term "Report" herein refers to the Property Information Report and the documents attached hereto.

Period Searched: May 6, 1975 to and including January 13, 2021 Abstractor: Vicki Campbell

BY

A handwritten signature in black ink, appearing to read "Michael A. Campbell".

Michael A. Campbell,
As President

Dated: January 14, 2021

PROPERTY INFORMATION REPORT
CONTINUATION PAGE

January 14, 2021

Tax Account #: 07-4448-050

1. The Grantee(s) of the last deed(s) of record is/are: **JERRY PITMAN, AS TRUSTEE OF THE TRUST IN THE LAST WILL & TESTAMENT OF ELMER W. PITMAN, JR.,**

By Virtue of Personal Representative's Deed recorded 4/15/2008 – OR 6314/867

ABTRACTOR'S NOTE: INCLUDED FOR YOUR INFORMATION COPY OF LW&T OF ELMER W. PITMAN, JR. WE FIND NO PROOF OF DEATH OF LYNE MARIE PITMAN AND WE HAVE INCLUDED ALL HEIRS OF ELMER W. PITMAN, JR. FOR NOTIFICATION.

2. The land covered by this Report is: **See Attached Exhibit "A"**

3. The following unsatisfied mortgages, liens, and judgments affecting the land covered by this Report appear of record:
 - a. **NONE**

4. Taxes:

Taxes for the year(s) 2017-2019 are delinquent.

Tax Account #: 07-4448-050

Assessed Value: \$117,350

Exemptions: HOMESTEAD EXEMPTION

5. We find the following HOA names in our search (if a condominium, the condo docs book and page are included for your review): **NONE**

Payment of any special liens/assessments imposed by City, County, and/or State.

Note: Escambia County and/or local municipalities may impose special liens/assessments. These liens/assessments are not discovered in a title search or shown above. These special assessments typically create a lien on real property. The entity that governs subject property must be contacted to verify payment status.

PERDIDO TITLE & ABSTRACT, INC.
PROPERTY INFORMATION REPORT
3050 Concho Drive, Pensacola, Florida 32507 | Phone 850-466-3077

Scott Lunsford
Escambia County Tax Collector
P.O. Box 1312
Pensacola, FL 32591

CERTIFICATION: TITLE SEARCH FOR TDA

TAX DEED SALE DATE: APR 5, 2021

TAX ACCOUNT #: 07-4448-050

CERTIFICATE #: 2018-3941

In compliance with Section 197.522, Florida Statutes, the following is a list of names and addresses of those persons, firms, and/or agencies having legal interest in or claim against the above-described property. The above-referenced tax sale certificate is being submitted as proper notification of tax deed sale.

YES NO

 X Notify City of Pensacola, P.O. Box 12910, 32521
 X Notify Escambia County, 190 Governmental Center, 32502
 X Homestead for 2020 tax year.

**JERRY PITMAN AS TRUSTEE OF
THE TRUST IN THE LAST WILL &
TESTAMENT OF ELMER W. PITMAN, JR.,
11440 EMPIRE GRADE ROAD
SANT CRUZ, CA 95060-9645**

**JERRY PITMAN AS TRUSTEE OF
THE TRUST IN THE LAST WILL &
TESTAMENT OF ELMER W. PITMAN, JR.,
AND LYNE PITMAN
301 N PINWOOD LN.
PENSACOLA, FL 32507**

Certified and delivered to Escambia County Tax Collector, this January 14th day of January, 2021.

PERDIDO TITLE & ABSTRACT, INC.



BY: Michael A. Campbell, As It's President

NOTE: The above listed addresses are based upon current information available, but addresses are not guaranteed to be true or correct.

PROPERTY INFORMATION REPORT

July 24, 2020

Tax Account #: 07-4448-050

**LEGAL DESCRIPTION
EXHIBIT "A"**

**BEG AT INTER OF W LI OF 1ST ST AND N LI OF THIRD AVE NLY 360 FT FOR POB W 60 FT N
TO BAYOU ELY ALG BAYOU TO W LI OF 1ST ST SLY ALG 1ST ST 230 FT TO POB LT 1 BLK 17
OF AN UNRECORDED PLAT OR 6314 P 867 CASE 2006 CP 2296 CA 160**

SECTION 38, TOWNSHIP 2 S, RANGE 30 W

TAX ACCOUNT NUMBER 07-4448-050 (0421-42)

RELEASE OF NOTICE OF APPLICATION FOR TAX DEED

Pursuant to § 197.502(5)(c), Florida Statutes, the Escambia County Clerk of Court fully releases the Notice of Tax Deed Application recorded at Official Records Book 8294, Page 878, of Escambia County, for the tax certificate, tax deed, and property described below:

Tax Certificate No. Certificate No. 03941, issued the 1st day of June, A.D., 2018

TAX ACCOUNT NUMBER: 074448050 (0421-42)

DESCRIPTION OF PROPERTY:

**BEG AT INTER OF W LI OF 1ST ST AND N LI OF THIRD AVE NLY 360 FT FOR POB W 60 FT
N TO BAYOU ELY ALG BAYOU TO W LI OF 1ST ST SLY ALG 1ST ST 230 FT TO POB LT 1
BLK 17 OF AN UNRECORDED PLAT OR 6314 P 867 CASE # 2006 CP 2295 CA 160**

SECTION 38, TOWNSHIP 2 S, RANGE 30 W

NAME IN WHICH ASSESSED: JERRY PITMAN TRUSTEE and ELMER W PITMAN JR TRUST

Dated this 19th day of February 2021.

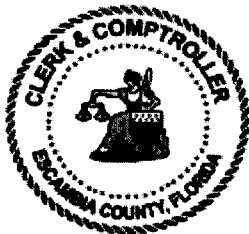

PAM CHILDERS
CLERK OF THE CIRCUIT COURT
ESCAMBIA COUNTY, FLORIDA

By:
Emily Hogg
Deputy Clerk

Redeemed From Sale



PAM CHILDERS
CLERK OF THE CIRCUIT COURT
ESCAMBIA COUNTY, FLORIDA

Tax Deed - Redemption Calculator

Account: 074448050 Certificate Number: 003941 of 2018

Redemption	<input type="text" value="Yes"/>	Application Date	<input type="text" value="04/21/2020"/>	Interest Rate	<input type="text" value="18%"/>
		Final Redemption Payment	ESTIMATED	Redemption Overpayment	ACTUAL
		Auction Date	<input type="text" value="04/05/2021"/>	Redemption Date	<input type="text" value="02/19/2021"/> 
Months			12		10
Tax Collector		<input type="text" value="\$4,311.79"/>		<input type="text" value="\$4,311.79"/>	
Tax Collector Interest		\$776.12		\$646.77	
Tax Collector Fee		<input type="text" value="\$6.25"/>		<input type="text" value="\$6.25"/>	
Total Tax Collector		\$5,094.16		\$4,964.81	T.C.
Record TDA Notice		<input type="text" value="\$17.00"/>		<input type="text" value="\$17.00"/>	
Clerk Fee		<input type="text" value="\$130.00"/>		<input type="text" value="\$130.00"/>	
Sheriff Fee		<input type="text" value="\$120.00"/>		<input type="text" value="\$120.00"/>	
Legal Advertisement		<input type="text" value="\$200.00"/>		<input type="text" value="\$200.00"/>	
App. Fee Interest		\$84.06		\$70.05	
Total Clerk		\$551.06		\$537.05	C.H.
Release TDA Notice (Recording)		<input type="text" value="\$10.00"/>		<input type="text" value="\$10.00"/>	
Release TDA Notice (Prep Fee)		<input type="text" value="\$7.00"/>		<input type="text" value="\$7.00"/>	
Postage		<input type="text" value="\$30.00"/>		<input type="text" value="\$30.00"/>	
Researcher Copies		<input type="text" value="\$0.00"/>		<input type="text" value="\$0.00"/>	
Total Redemption Amount		\$5,692.22		\$5,548.86	
		Repayment Overpayment Refund Amount		\$143.36	
Book/Page		<input type="text" value="8294"/>		<input type="text" value="878"/>	

PAM CHILDERS
 CLERK OF THE CIRCUIT COURT
 ARCHIVES AND RECORDS
 CHILDSUPPORT
 CIRCUIT CIVIL
 CIRCUIT CRIMINAL
 COUNTY CIVIL
 COUNTY CRIMINAL
 DOMESTIC RELATIONS
 FAMILY LAW
 JURY ASSEMBLY
 JUVENILE
 MENTAL HEALTH
 MIS
 OPERATIONAL SERVICES
 PROBATE
 TRAFFIC



**COUNTY OF ESCAMBIA
 OFFICE OF THE
 CLERK OF THE CIRCUIT COURT**

**BRANCH OFFICES
 ARCHIVES AND RECORDS
 JUVENILE DIVISION
 CENTURY**

CLERK TO THE BOARD OF
 COUNTY COMMISSIONERS
 OFFICIAL RECORDS
 COUNTY TREASURY
 AUDITOR

**PAM CHILDERS, CLERK OF THE CIRCUIT COURT
 Tax Certificate Redeemed From Sale
 Account: 074448050 Certificate Number: 003941 of 2018**

**Payor: LYNE MARIE PITMAN 301 N PINWOOD LN PENSACOLA, FL 32507 Date
 02/18/2021**

Clerk's Check # 10000105016
 Tax Collector Check # 1

Clerk's Total	\$551.06	\$5,501.86
Tax Collector's Total	\$5,094.16	
Postage	\$30.00	
Researcher Copies	\$0.00	
Recording	\$10.00	
Prep Fee	\$7.00	
Total Received	\$5,692.22	\$548.86

**PAM CHILDERS
 Clerk of the Circuit Court**

Received By: Whitney Coppage
 Deputy Clerk

PAM CHILDERS
 CLERK OF THE CIRCUIT COURT
 ARCHIVES AND RECORDS
 CHILDSUPPORT
 CIRCUIT CIVIL
 CIRCUIT CRIMINAL
 COUNTY CIVIL
 COUNTY CRIMINAL
 DOMESTIC RELATIONS
 FAMILY LAW
 JURY ASSEMBLY
 JUVENILE
 MENTAL HEALTH
 MIS
 OPERATIONAL SERVICES
 PROBATE
 TRAFFIC



**COUNTY OF ESCAMBIA
 OFFICE OF THE
 CLERK OF THE CIRCUIT COURT**

**BRANCH OFFICES
 ARCHIVES AND RECORDS
 JUVENILE DIVISION
 CENTURY**

CLERK TO THE BOARD OF
 COUNTY COMMISSIONERS
 OFFICIAL RECORDS
 COUNTY TREASURY
 AUDITOR

**Case # 2018 TD 003941
 Redeemed Date 02/18/2021**

Name LYNE MARIE PITMAN 301 N PINWOOD LN PENSACOLA, FL 32507

Clerk's Total = TAXDEED	\$551.06	\$5,094.16 \$5,501.86
Due Tax Collector = TAXDEED	\$5,094.16	
Postage = TD2	\$30.00	
ResearcherCopies = TD6	\$0.00	
Release TDA Notice (Recording) = RECORD2	\$10.00	
Release TDA Notice (Prep Fee) = TD4	\$7.00	

• For Office Use Only

Date	Docket	Desc	Amount Owed	Amount Due	Payee Name
------	--------	------	-------------	------------	------------

FINANCIAL SUMMARY

No Information Available - See Dockets

STATE OF FLORIDA
COUNTY OF ESCAMBIA

CERTIFICATE OF NOTICE OF MAILING
NOTICE OF APPLICATION FOR TAX DEED

CERTIFICATE # 03941 of 2018

I, PAM CHILDERS, CLERK OF THE CIRCUIT COURT OF ESCAMBIA COUNTY, FLORIDA, do hereby certify that I did on February 18, 2021, mail a copy of the foregoing Notice of Application for Tax Deed, addressed to:

JERRY PITMAN TRUSTEE C/O LYNE PITMAN 301 N PINWOOD LN PENSACOLA, FL 32507	ELMER W PITMAN JR TRUST C/O LYNE PITMAN 301 N PINWOOD LN PENSACOLA, FL 32507
--	---

JERRY PITMAN TRUSTEE 11440 EMPIRE GRADE ROAD SANTA CRUZ CA 95060-9645	ELMER W PITMAN JR TRUST 11440 EMPIRE GRADE ROAD SANTA CRUZ CA 95060-9645
---	--

LYNE MARIE PITMAN 127 CAVALIER DRIVE PENSACOLA FL 32507

WITNESS my official seal this 18th day of February 2021.

PAM CHILDERS
CLERK OF THE CIRCUIT COURT
ESCAMBIA COUNTY, FLORIDA



By:
Emily Hogg
Deputy Clerk

WARNING

THERE ARE UNPAID TAXES ON PROPERTY WHICH YOU OWN OR IN WHICH YOU HAVE A LEGAL INTEREST. THE PROPERTY WILL BE SOLD AT PUBLIC AUCTION ON April 5, 2021, UNLESS THE TAXES ARE PAID. SHOULD YOU NEED FURTHER INFORMATION CONTACT THE CLERK OF THE CIRCUIT COURT IMMEDIATELY AT THE COUNTY COURTHOUSE IN PENSACOLA, FLORIDA, OR CALL 850-595-3793.

NOTICE OF APPLICATION FOR TAX DEED

NOTICE IS HEREBY GIVEN, That **TLOA OF FLORIDA LLC CAPITOL ONE BANK C/O TLOA HOLDINGS LLC** holder of Tax Certificate No. 03941, issued the 1st day of June, A.D., 2018 has filed same in my office and has made application for a tax deed to be issued thereon. Said certificate embraces the following described property in the County of Escambia, State of Florida, to wit:

BEG AT INTER OF W LI OF 1ST ST AND N LI OF THIRD AVE NLY 360 FT FOR POB W 60 FT N TO BAYOU ELY ALG BAYOU TO W LI OF 1ST ST SLY ALG 1ST ST 230 FT TO POB LT 1 BLK 17 OF AN UNRECORDED PLAT OR 6314 P 867 CASE # 2006 CP 2295 CA 160

SECTION 38, TOWNSHIP 2 S, RANGE 30 W

TAX ACCOUNT NUMBER 074448050 (0421-42)

The assessment of the said property under the said certificate issued was in the name of

JERRY PITMAN TRUSTEE and ELMER W PITMAN JR TRUST

Unless said certificate shall be redeemed according to law, the property described therein will be sold to the highest bidder at public auction at 9:00 A.M. on the first Monday in the month of April, which is the 5th day of April 2021.

Dated this 9th day of February 2021.

In accordance with the AMERICANS WITH DISABILITIES ACT, if you are a person with a disability who needs special accommodation in order to participate in this proceeding you are entitled to the provision of certain assistance. Please contact Emily Hogg not later than seven days prior to the proceeding at Escambia County Government Complex, 221 Palafox Place Ste 110, Pensacola FL 32502. Telephone: 850-595-3793.



PAM CHILDERS
CLERK OF THE CIRCUIT COURT
ESCAMBIA COUNTY, FLORIDA

By:
Emily Hogg
Deputy Clerk

WARNING

THERE ARE UNPAID TAXES ON PROPERTY WHICH YOU OWN OR IN WHICH YOU HAVE A LEGAL INTEREST. THE PROPERTY WILL BE SOLD AT PUBLIC AUCTION ON April 5, 2021, UNLESS THE TAXES ARE PAID. SHOULD YOU NEED FURTHER INFORMATION CONTACT THE CLERK OF THE CIRCUIT COURT IMMEDIATELY AT THE COUNTY COURTHOUSE IN PENSACOLA, FLORIDA, OR CALL 850-595-3793.

NOTICE OF APPLICATION FOR TAX DEED

NOTICE IS HEREBY GIVEN, That TLOA OF FLORIDA LLC CAPITOL ONE BANK C/O TLOA HOLDINGS LLC holder of Tax Certificate No. 03941, issued the 1st day of June, A.D., 2018 has filed same in my office and has made application for a tax deed to be issued thereon. Said certificate embraces the following described property in the County of Escambia, State of Florida, to wit:

BEG AT INTER OF W LI OF 1ST ST AND N LI OF THIRD AVE NLY 360 FT FOR POB W 60 FT N TO BAYOU ELY ALG BAYOU TO W LI OF 1ST ST SLY ALG 1ST ST 230 FT TO POB LT 1 BLK 17 OF AN UNRECORDED PLAT OR 6314 P 867 CASE # 2006 CP 2295 CA 160

SECTION 38, TOWNSHIP 2 S, RANGE 30 W

TAX ACCOUNT NUMBER 074448050 (0421-42)

The assessment of the said property under the said certificate issued was in the name of

JERRY PITMAN TRUSTEE and ELMER W PITMAN JR TRUST

Unless said certificate shall be redeemed according to law, the property described therein will be sold to the highest bidder at public auction at 9:00 A.M. on the first Monday in the month of April, which is the 5th day of April 2021.

Dated this 9th day of February 2021.

In accordance with the AMERICANS WITH DISABILITIES ACT, if you are a person with a disability who needs special accommodation in order to participate in this proceeding you are entitled to the provision of certain assistance. Please contact Emily Hogg not later than seven days prior to the proceeding at Escambia County Government Complex, 221 Palafox Place Ste 110, Pensacola FL 32502. Telephone: 850-595-3793.

Post Property:

301 N PINWOOD LN 32507



PAM CHILDERS
CLERK OF THE CIRCUIT COURT
ESCAMBIA COUNTY, FLORIDA



By:
Emily Hogg
Deputy Clerk

WARNING

THERE ARE UNPAID TAXES ON PROPERTY WHICH YOU OWN OR IN WHICH YOU HAVE A LEGAL INTEREST. THE PROPERTY WILL BE SOLD AT PUBLIC AUCTION ON April 5, 2021, UNLESS THE TAXES ARE PAID. SHOULD YOU NEED FURTHER INFORMATION CONTACT THE CLERK OF THE CIRCUIT COURT IMMEDIATELY AT THE COUNTY COURTHOUSE IN PENSACOLA, FLORIDA, OR CALL 850-595-3793.

NOTICE OF APPLICATION FOR TAX DEED

NOTICE IS HEREBY GIVEN, That TLOA OF FLORIDA LLC CAPITOL ONE BANK C/O TLOA HOLDINGS LLC holder of Tax Certificate No. 03941, issued the 1st day of June, A.D., 2018 has filed same in my office and has made application for a tax deed to be issued thereon. Said certificate embraces the following described property in the County of Escambia, State of Florida, to wit:

BEG AT INTER OF W LI OF 1ST ST AND N LI OF THIRD AVE NLY 360 FT FOR POB W 60 FT N TO BAYOU ELY ALG BAYOU TO W LI OF 1ST ST SLY ALG 1ST ST 230 FT TO POB LT 1 BLK 17 OF AN UNRECORDED PLAT OR 6314 P 867 CASE # 2006 CP 2295 CA 160

SECTION 38, TOWNSHIP 2 S, RANGE 30 W

TAX ACCOUNT NUMBER 074448050 (0421-42)

The assessment of the said property under the said certificate issued was in the name of

JERRY PITMAN TRUSTEE and ELMER W PITMAN JR TRUST

Unless said certificate shall be redeemed according to law, the property described therein will be sold to the highest bidder at public auction at 9:00 A.M. on the first Monday in the month of April, which is the 5th day of April 2021.

Dated this 9th day of February 2021.

In accordance with the AMERICANS WITH DISABILITIES ACT, if you are a person with a disability who needs special accommodation in order to participate in this proceeding you are entitled to the provision of certain assistance. Please contact Emily Hogg not later than seven days prior to the proceeding at Escambia County Government Complex, 221 Palafox Place Ste 110, Pensacola FL 32502. Telephone: 850-595-3793.

Personal Services:

JERRY PITMAN TRUSTEE
C/O LYNE PITMAN
301 N PINWOOD LN
PENSACOLA, FL 32507

PAM CHILDERS
CLERK OF THE CIRCUIT COURT
ESCAMBIA COUNTY, FLORIDA

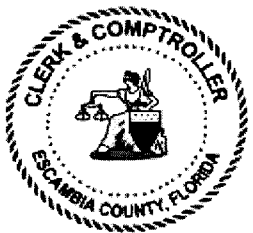

By:
Emily Hogg
Deputy Clerk



WARNING

THERE ARE UNPAID TAXES ON PROPERTY WHICH YOU OWN OR IN WHICH YOU HAVE A LEGAL INTEREST. THE PROPERTY WILL BE SOLD AT PUBLIC AUCTION ON April 5, 2021, UNLESS THE TAXES ARE PAID. SHOULD YOU NEED FURTHER INFORMATION CONTACT THE CLERK OF THE CIRCUIT COURT IMMEDIATELY AT THE COUNTY COURTHOUSE IN PENSACOLA, FLORIDA, OR CALL 850-595-3793.

NOTICE OF APPLICATION FOR TAX DEED

NOTICE IS HEREBY GIVEN, That TLOA OF FLORIDA LLC CAPITOL ONE BANK C/O TLOA HOLDINGS LLC holder of Tax Certificate No. 03941, issued the 1st day of June, A.D., 2018 has filed same in my office and has made application for a tax deed to be issued thereon. Said certificate embraces the following described property in the County of Escambia, State of Florida, to wit:

BEG AT INTER OF W LI OF 1ST ST AND N LI OF THIRD AVE NLY 360 FT FOR POB W 60 FT N TO BAYOU ELY ALG BAYOU TO W LI OF 1ST ST SLY ALG 1ST ST 230 FT TO POB LT 1 BLK 17 OF AN UNRECORDED PLAT OR 6314 P 867 CASE # 2006 CP 2295 CA 160

SECTION 38, TOWNSHIP 2 S, RANGE 30 W

TAX ACCOUNT NUMBER 074448050 (0421-42)

The assessment of the said property under the said certificate issued was in the name of

JERRY PITMAN TRUSTEE and ELMER W PITMAN JR TRUST

Unless said certificate shall be redeemed according to law, the property described therein will be sold to the highest bidder at public auction at 9:00 A.M. on the first Monday in the month of April, which is the 5th day of April 2021.

Dated this 9th day of February 2021.

In accordance with the AMERICANS WITH DISABILITIES ACT, if you are a person with a disability who needs special accommodation in order to participate in this proceeding you are entitled to the provision of certain assistance. Please contact Emily Hogg not later than seven days prior to the proceeding at Escambia County Government Complex, 221 Palafox Place Ste 110, Pensacola FL 32502. Telephone: 850-595-3793.

Personal Services:

ELMER W PITMAN JR TRUST
C/O LYNE PITMAN
301 N PINWOOD LN
PENSACOLA, FL 32507

PAM CHILDERS
CLERK OF THE CIRCUIT COURT
ESCAMBIA COUNTY, FLORIDA



By:
Emily Hogg
Deputy Clerk

ESCAMBIA COUNTY SHERIFF'S OFFICE
ESCAMBIA COUNTY, FLORIDA

Redeemed

NON-ENFORCEABLE RETURN OF SERVICE

0421-42

Document Number: ECSO21CIV006692NON

Agency Number: 21-004297

Court: TAX DEED

County: ESCAMBIA

Case Number: CERT NO 03941 2018

Attorney/Agent:

PAM CHILDERS
CLERK OF COURT
TAX DEED

Plaintiff: RE: JERRY PITMAN TRUSTEE AND ELMER W PITMAN JR TRUST
Defendant:

Type of Process: NOTICE OF APPLICATION FOR TAX DEED

Received this Writ on 2/19/2021 at 8:57 AM and served same at 3:26 PM on 2/19/2021 in ESCAMBIA COUNTY, FLORIDA, by serving POST PROPERTY , the within named, to wit: , .

POSTED TO THE PROPERTY AS INSTRUCTED BY THE CLERKS OFFICE

CHIP W SIMMONS, SHERIFF
ESCAMBIA COUNTY, FLORIDA

By: _____

L. Littlejohn 927

L. LITTLEJOHN, CPS

Service Fee: \$40.00

Receipt No: BILL

Printed By: LCMITCHE

WARNING

THERE ARE UNPAID TAXES ON PROPERTY WHICH YOU OWN OR IN WHICH YOU HAVE A LEGAL INTEREST. THE PROPERTY WILL BE SOLD AT PUBLIC AUCTION ON April 5, 2021, UNLESS THE TAXES ARE PAID. SHOULD YOU NEED FURTHER INFORMATION CONTACT THE CLERK OF THE CIRCUIT COURT IMMEDIATELY AT THE COUNTY COURTHOUSE IN PENSACOLA, FLORIDA, OR CALL 850-595-3793.

NOTICE OF APPLICATION FOR TAX DEED

NOTICE IS HEREBY GIVEN, That **TLOA OF FLORIDA LLC CAPITOL ONE BANK C/O TLOA HOLDINGS LLC** holder of Tax Certificate No. **03941**, issued the 1st day of **June, A.D., 2018** has filed same in my office and has made application for a tax deed to be issued thereon. Said certificate embraces the following described property in the County of Escambia, State of Florida, to wit:

BEG AT INTER OF W LI OF 1ST ST AND N LI OF THIRD AVE NLY 360 FT FOR POB W 60 FT N TO BAYOU ELY ALG BAYOU TO W LI OF 1ST ST SLY ALG 1ST ST 230 FT TO POB LT 1 BLK 17 OF AN UNRECORDED PLAT OR 6314 P 867 CASE # 2006 CP 2295 CA 160

SECTION 38, TOWNSHIP 2 S, RANGE 30 W

TAX ACCOUNT NUMBER 074448050 (0421-42)

The assessment of the said property under the said certificate issued was in the name of

JERRY PITMAN TRUSTEE and ELMER W PITMAN JR TRUST

Unless said certificate shall be redeemed according to law, the property described therein will be sold to the highest bidder at public auction at 9:00 A.M. on the **first Monday** in the month of April, which is the **5th day of April 2021**.

Dated this 9th day of February 2021.

In accordance with the AMERICANS WITH DISABILITIES ACT, if you are a person with a disability who needs special accommodation in order to participate in this proceeding you are entitled to the provision of certain assistance. Please contact Emily Hogg not later than seven days prior to the proceeding at Escambia County Government Complex, 221 Palafox Place Ste 110, Pensacola FL 32502. Telephone: 850-595-3793.

Post Property:

301 N PINWOOD LN 32507



**PAM CHILDERS
CLERK OF THE CIRCUIT COURT
ESCAMBIA COUNTY, FLORIDA**

By:
Emily Hogg
Deputy Clerk

ESCAMBIA COUNTY
SHERIFF'S OFFICE
CIVIL UNIT

2021 FEB 19 AM 8:57

RECEIVED

ESCAMBIA COUNTY SHERIFF'S OFFICE
ESCAMBIA COUNTY, FLORIDA

Redeemed

NON-ENFORCEABLE RETURN OF SERVICE

0421-42

Document Number: ECSO21CIV006650NON

Agency Number: 21-004323

Court: TAX DEED

County: ESCAMBIA

Case Number: CERT NO 03941 2018

Attorney/Agent:

PAM CHILDERS
CLERK OF COURT
TAX DEED

Plaintiff: RE JERRY PITMAN TRUSTEE and ELMER W PITMAN JR TRUST
Defendant:

Type of Process: NOTICE OF APPLICATION FOR TAX DEED

Received this Writ on 2/19/2021 at 8:58 AM and served same at 3:26 PM on 2/19/2021 in ESCAMBIA COUNTY, FLORIDA, by serving JERRY PITMAN TRUSTEE , the within named, to wit: LYNE PITMAN, REPRESENTATIVE.

CHIP W SIMMONS, SHERIFF
ESCAMBIA COUNTY, FLORIDA

By: _____

L. Littlejohn

L. LITTLEJOHN, CPS

Service Fee: \$40.00

Receipt No: BILL

Printed By: LCMITCHE

WARNING

004323

THERE ARE UNPAID TAXES ON PROPERTY WHICH YOU OWN OR IN WHICH YOU HAVE A LEGAL INTEREST. THE PROPERTY WILL BE SOLD AT PUBLIC AUCTION ON April 5, 2021, UNLESS THE TAXES ARE PAID. SHOULD YOU NEED FURTHER INFORMATION CONTACT THE CLERK OF THE CIRCUIT COURT IMMEDIATELY AT THE COUNTY COURTHOUSE IN PENSACOLA, FLORIDA, OR CALL 850-595-3793.

NOTICE OF APPLICATION FOR TAX DEED

NOTICE IS HEREBY GIVEN, That TLOA OF FLORIDA LLC CAPITOL ONE BANK C/O TLOA HOLDINGS LLC holder of Tax Certificate No. 03941, issued the 1st day of June, A.D., 2018 has filed same in my office and has made application for a tax deed to be issued thereon. Said certificate embraces the following described property in the County of Escambia, State of Florida, to wit:

BEG AT INTER OF W LI OF 1ST ST AND N LI OF THIRD AVE NLY 360 FT FOR POB W 60 FT N TO BAYOU ELY ALG BAYOU TO W LI OF 1ST ST SLY ALG 1ST ST 230 FT TO POB LT 1 BLK 17 OF AN UNRECORDED PLAT OR 6314 P 867 CASE # 2006 CP 2295 CA 160

SECTION 38, TOWNSHIP 2 S, RANGE 30 W

TAX ACCOUNT NUMBER 074448050 (0421-42)

The assessment of the said property under the said certificate issued was in the name of

JERRY PITMAN TRUSTEE and ELMER W PITMAN JR TRUST

Unless said certificate shall be redeemed according to law, the property described therein will be sold to the highest bidder at public auction at 9:00 A.M. on the first Monday in the month of April, which is the 5th day of April 2021.

Dated this 9th day of February 2021.

In accordance with the AMERICANS WITH DISABILITIES ACT, if you are a person with a disability who needs special accommodation in order to participate in this proceeding you are entitled to the provision of certain assistance. Please contact Emily Hogg not later than seven days prior to the proceeding at Escambia County Government Complex, 221 Palafox Place Ste 110, Pensacola FL 32502. Telephone: 850-595-3793.

Personal Services:

JERRY PITMAN TRUSTEE
C/O LYNE PITMAN
301 N PINWOOD LN
PENSACOLA, FL 32507

PAM CHILDERS
CLERK OF THE CIRCUIT COURT
ESCAMBIA COUNTY, FLORIDA



By:
Emily Hogg
Deputy Clerk

ESCAMBIA COUNTY,
SHERIFF'S OFFICE,
CIVIL UNIT

2021 FEB 19 AM 8:58

RECEIVED

ESCAMBIA COUNTY SHERIFF'S OFFICE
ESCAMBIA COUNTY, FLORIDA

Redeemed

NON-ENFORCEABLE RETURN OF SERVICE

0421-42

Document Number: ECSO21CIV006652NON

Agency Number: 21-004324

Court: TAX DEED

County: ESCAMBIA

Case Number: CERT NO 03941 2018

Attorney/Agent:

PAM CHILDERS
CLERK OF COURT
TAX DEED

Plaintiff: RE JERRY PITMAN TRUSTEE and ELMER W PITMAN JR TRUST

Defendant:

Type of Process: NOTICE OF APPLICATION FOR TAX DEED

Received this Writ on 2/19/2021 at 8:58 AM and served same at 3:26 PM on 2/19/2021 in ESCAMBIA COUNTY, FLORIDA, by serving ELMER W PITMAN JR TRUST , the within named, to wit: LYNE PITMAN, REPRESENTATIVE.

CHIP W SIMMONS, SHERIFF
ESCAMBIA COUNTY, FLORIDA

By: _____

L. Littlejohn

L. LITTLEJOHN, CPS

Service Fee: \$40.00

Receipt No: BILL

Printed By: LCMITCHE

THERE ARE UNPAID TAXES ON PROPERTY WHICH YOU OWN OR IN WHICH YOU HAVE A LEGAL INTEREST. THE PROPERTY WILL BE SOLD AT PUBLIC AUCTION ON April 5, 2021, UNLESS THE TAXES ARE PAID. SHOULD YOU NEED FURTHER INFORMATION CONTACT THE CLERK OF THE CIRCUIT COURT IMMEDIATELY AT THE COUNTY COURTHOUSE IN PENSACOLA, FLORIDA, OR CALL 850-595-3793.

NOTICE OF APPLICATION FOR TAX DEED

NOTICE IS HEREBY GIVEN, That TLOA OF FLORIDA LLC CAPITOL ONE BANK C/O TLOA HOLDINGS LLC holder of Tax Certificate No. 03941, issued the 1st day of June, A.D., 2018 has filed same in my office and has made application for a tax deed to be issued thereon. Said certificate embraces the following described property in the County of Escambia, State of Florida, to wit:

BEG AT INTER OF W LI OF 1ST ST AND N LI OF THIRD AVE NLY 360 FT FOR POB W 60 FT N TO BAYOU ELY ALG BAYOU TO W LI OF 1ST ST SLY ALG 1ST ST 230 FT TO POB LT 1 BLK 17 OF AN UNRECORDED PLAT OR 6314 P 867 CASE # 2006 CP 2295 CA 160

SECTION 38, TOWNSHIP 2 S, RANGE 30 W

TAX ACCOUNT NUMBER 074448050 (0421-42)

The assessment of the said property under the said certificate issued was in the name of

JERRY PITMAN TRUSTEE and ELMER W PITMAN JR TRUST

Unless said certificate shall be redeemed according to law, the property described therein will be sold to the highest bidder at public auction at 9:00 A.M. on the first Monday in the month of April, which is the 5th day of April 2021.

Dated this 9th day of February 2021.

In accordance with the AMERICANS WITH DISABILITIES ACT, if you are a person with a disability who needs special accommodation in order to participate in this proceeding you are entitled to the provision of certain assistance. Please contact Emily Hogg not later than seven days prior to the proceeding at Escambia County Government Complex, 221 Palafox Place Ste 110, Pensacola FL 32502. Telephone: 850-595-3793.

Personal Services:

ELMER W PITMAN JR TRUST
C/O LYNE PITMAN
301 N PINWOOD LN
PENSACOLA, FL 32507

PAM CHILDERS
CLERK OF THE CIRCUIT COURT
ESCAMBIA COUNTY, FLORIDA



By:
Emily Hogg
Deputy Clerk

RECEIVED
2021 FEB 19 AM 8:58
ESCAMBIA COUNTY
SHERIFF'S OFFICE
CIVIL UNIT

JERRY PITMAN TRUSTEE [0421-42]
C/O LYNE PITMAN
301 N PINWOOD LN
PENSACOLA, FL 32507

9171 9690 0935 0127 9940 74

ELMER W PITMAN JR TRUST [0421-42]
C/O LYNE PITMAN
301 N PINWOOD LN
PENSACOLA, FL 32507

9171 9690 0935 0127 9940 81

JERRY PITMAN TRUSTEE [0421-42]
11440 EMPIRE GRADE ROAD
SANTA CRUZ CA 95060-9645

9171 9690 0935 0127 9940 98

ELMER W PITMAN JR TRUST [0421-42]
11440 EMPIRE GRADE ROAD
SANTA CRUZ CA 95060-9645

9171 9690 0935 0127 9940 29

LYNE MARIE PITMAN [0421-42]
127 CAVALIER DRIVE
PENSACOLA FL 32507

9171 9690 0935 0127 9940 36

Redeemed

CERTIFIED MAIL™

Pam Childers

Clerk of the Circuit Court & Comptroller
Official Records

221 Palafox Place, Suite 110

Pensacola, FL 32502

FILED
CLERK & COMPTROLLER
2021 MAR - 1 P 2:32
PENSACOLA COUNTY, FL



9171 9690 0935 0127 9940 36

quadrant

FIRST-CLASS MAIL

\$005.86

02/18/2021 ZIP 32502
043M31219251

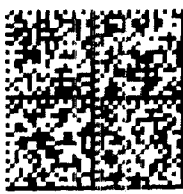

US POSTAGE

AK

LYNE MARIE PITMAN [0421-42]

127 CAVALIER DRIVE
PENSACOLA FL 32507

322 FEB 1 0002 / 25 / 21

RETURN TO SENDER
ATTEMPTED - NOT KNOWN
UNABLE TO FORWARD

ANK BC: 3250258335 *2187-01303-18-43

