

CERTIFICATION OF TAX DEED APPLICATION

Sections 197.502 and 197.542, Florida Statutes

513
R. 07/19

0321-09

Part 1: Tax Deed Application Information			
Applicant Name Applicant Address	ATCF II FLORIDA-A, LLC PO BOX 54972 NEW ORLEANS, LA 70154	Application date	Apr 07, 2020
Property description	GRAAL PROPERTIES INC PO BOX 11697 PENSACOLA, FL 32524-1697 505 FRISCO RD LT 3 BLK 3 1ST ADDN TO EDGEWATER PB 3 P 6 OR 5801 P 995 CA 179	Certificate #	2018 / 3903
		Date certificate issued	06/01/2018
		Deed application number	2000329
		Account number	07-3964-000

Part 2: Certificates Owned by Applicant and Filed with Tax Deed Application				
Column 1 Certificate Number	Column 2 Date of Certificate Sale	Column 3 Face Amount of Certificate	Column 4 Interest	Column 5: Total (Column 3 + Column 4)
# 2018/3903	06/01/2018	988.57	49.43	1,038.00
# 2019/3686	06/01/2019	1,024.47	51.22	1,075.69
→ Part 2: Total*				2,113.69

Part 3: Other Certificates Redeemed by Applicant (Other than County)					
Column 1 Certificate Number	Column 2 Date of Other Certificate Sale	Column 3 Face Amount of Other Certificate	Column 4 Tax Collector's Fee	Column 5 Interest	Total (Column 3 + Column 4 + Column 5)
# /					
Part 3: Total*					0.00

Part 4: Tax Collector Certified Amounts (Lines 1-7)	
1. Cost of all certificates in applicant's possession and other certificates redeemed by applicant (*Total of Parts 2 + 3 above)	2,113.69
2. Delinquent taxes paid by the applicant	0.00
3. Current taxes paid by the applicant	940.97
4. Property information report fee and Deed Application Recording and Release Fees	200.00
5. Tax deed application fee	175.00
6. Interest accrued by tax collector under s.197.542, F.S. (see Tax Collector Instructions, page 2)	0.00
7. Total Paid (Lines 1-6)	3,429.66

I certify the above information is true and the tax certificates, interest, property information report fee, and tax collector's fees have been paid, and that the property information statement is attached.

Sign here: <u><i>Shirley Rich, CFCA</i></u> Signature, Tax Collector or Designee <u><i>Deputy Tax Collector</i></u>	<u>Escambia County, Florida</u> Date <u>April 16th, 2020</u>
--	---

Send this certification to the Clerk of Court by 10 days after the date signed. See Instructions on Page 2

Part 5: Clerk of Court Certified Amounts (Lines 8-14)	
8. Processing tax deed fee	
9. Certified or registered mail charge	
10. Clerk of Court advertising, notice for newspaper, and electronic auction fees	
11. Recording fee for certificate of notice	
12. Sheriff's fees	
13. Interest (see Clerk of Court Instructions, page 2)	
14. Total Paid (Lines 8-13)	
15. Plus one-half of the assessed value of homestead property, if applicable under s. 197.502(6)(c), F.S.	
16. Other outstanding certificates and delinquent taxes not included in this Application, if applicable per Florida statutes	
17. Statutory opening bid (total of Lines 7, 14, 15, and 16 if applicable)	
18. Redemption fee	12.50
19. Total amount to redeem	
Sign here: _____ Date of sale <u>03/01/2021</u>	
Signature, Clerk of Court or Designee	

INSTRUCTIONS

Tax Collector (complete Parts 1-4)

Part 2: Certificates Owned by Applicant and Filed with Tax Deed Application

Enter the Face Amount of Certificate in Column 3 and the Interest in Column 4 for each certificate number. Add Columns 3 and 4 and enter the amount in Column 5.

Part 3: Other Certificates Redeemed by Applicant (Other than County)

Total. Add the amounts in Columns 3, 4 and 5

Part 4: Tax Collector Certified Amounts (Lines 1-7)

Line 1, enter the total of Part 2 plus the total of Part 3 above.

Total Paid, Line 7: Add the amounts of Lines 1-6

Line 6, Interest accrued by tax collector. Calculate the 1.5 percent interest accrued from the month after the date of application through the month this form is certified to the clerk. Enter the amount to be certified to the clerk on **Line 6.** The interest calculated by the tax collector stops before the interest calculated by the clerk begins. See Section 197.542, F.S., and Rule 12D-13.060(3), Florida Administrative Code.

The tax collector's interest for redemption at the time of the tax deed application is a cost of redemption, which encompasses various percentages of interest on certificates and omitted or delinquent taxes under Section 197.502, F.S. This interest is calculated before the tax collector calculates the interest in Section 197.542, F.S.

Attach certified statement of names and addresses of persons who must be notified before the sale of the property. Send this form and any required attachments to the Clerk of Court within 10 days after it is signed.

Clerk of Court (complete Part 5)

Line 13: Interest is calculated at the rate of 1.5 percent per month starting from the first day of the month after the month of certification of this form through the last day of the month in which the sale will be held. Multiply the calculated rate by the total of **Line 7,** minus **Line 6,** plus **Lines 8 through 12.** Enter the amount on **Line 13.**

Line 14: Enter the total of Lines 8-13. Complete Lines 15-18, if applicable.

APPLICATION FOR TAX DEED

Section 197.502, Florida Statutes

512
R. 12/16

Application Number: 2000329

To: Tax Collector of ESCAMBIA COUNTY, Florida

I,
ATCF II FLORIDA-A, LLC
PO BOX 54972
NEW ORLEANS, LA 70154,

hold the listed tax certificate and hereby surrender the same to the Tax Collector and make tax deed application thereon:

Account Number	Certificate No.	Date	Legal Description
07-3964-000	2018/3903	06-01-2018	LT 3 BLK 3 1ST ADDN TO EDGEWATER PB 3 P 6 OR 5801 P 995 CA 179

I agree to:

- pay any current taxes, if due and
- redeem all outstanding tax certificates plus interest not in my possession, and
- pay all delinquent and omitted taxes, plus interest covering the property.
- pay all Tax Collector's fees, property information report costs, Clerk of the Court costs, charges and fees, and Sheriff's costs, if applicable.

Attached is the tax sale certificate on which this application is based and all other certificates of the same legal description which are in my possession.

Electronic signature on file
ATCF II FLORIDA-A, LLC
PO BOX 54972
NEW ORLEANS, LA 70154

04-07-2020
Application Date

Applicant's signature



Chris Jones Escambia County Property Appraiser

Real Estate Search

Tangible Property Search

Sale List

[Back](#)

← [Navigate Mode](#) [Account](#) [Reference](#) →

[Printer Friendly Version](#)

General Information	
Reference:	372S301001003004
Account:	073964000
Owners:	GRAAL PROPERTIES INC
Mail:	PO BOX 11697 PENSACOLA, FL 32524-1697
Situs:	505 FRISCO RD 32507
Use Code:	SINGLE FAMILY RESID
Taxing Authority:	COUNTY MSTU
Tax Inquiry:	Open Tax Inquiry Window
Tax Inquiry link courtesy of Scott Lunsford Escambia County Tax Collector	

Assessments				
Year	Land	Imprv	Total	Cap Val
2019	\$8,000	\$51,379	\$59,379	\$59,379
2018	\$8,000	\$47,709	\$55,709	\$55,709
2017	\$8,000	\$44,230	\$52,230	\$52,230

Disclaimer

Tax Estimator

> File for New Homestead Exemption Online

Sales Data					
Sale Date	Book	Page	Value	Type	Official Records (New Window)
12/2005	5801	995	\$96,000	WD	View Instr
04/2003	5126	1419	\$30,300	WD	View Instr
10/1995	3857	695	\$20,500	WD	View Instr
08/1995	3822	773	\$100	CT	View Instr

Official Records Inquiry courtesy of Pam Childers
Escambia County Clerk of the Circuit Court and Comptroller

2019 Certified Roll Exemptions
None

Legal Description
LT 3 BLK 3 1ST ADDN TO EDGEWATER PB 3 P 6 OR 5801 P 995 CA 179

Extra Features
None

Parcel Information [Launch Interactive Map](#)

Section Map Id:
CA180

Approx. Acreage:
0.1965

Zoned:
MDR

Evacuation & Flood Information
[Open Report](#)

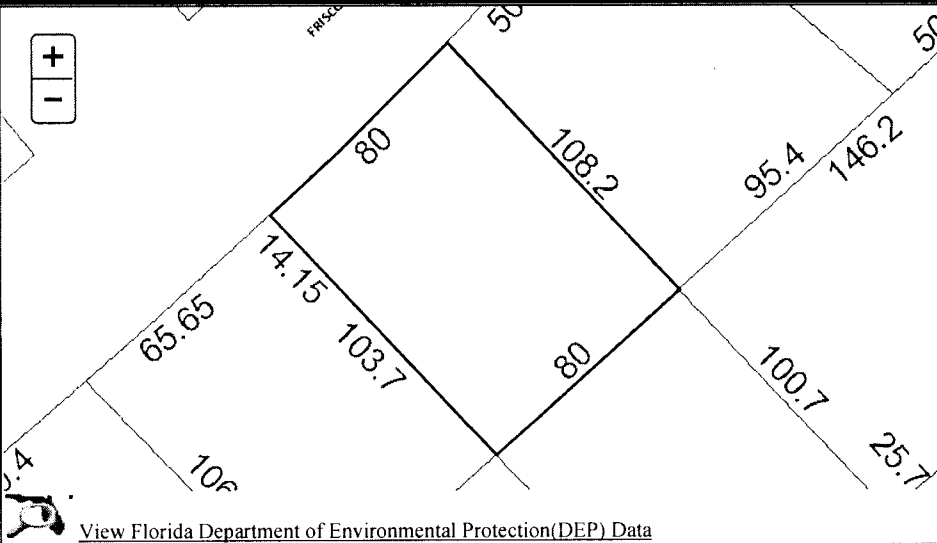

Buildings

Address: 505 FRISCO RD, Year Built: 1952, Effective Year: 1965	
Structural Elements	
DECOR/MILLWORK-AVERAGE	
DWELLING UNITS-1	
EXTERIOR WALL-ASBESTOS SIDING	
FLOOR COVER-CARPET	
FOUNDATION-WOOD/SUB FLOOR	

HEAT/AIR-CENTRAL H/AC
INTERIOR WALL-DRYWALL-PLASTER
NO. PLUMBING FIXTURES-3
NO. STORIES-1
ROOF COVER-DIMEN/ARCH SHNG
ROOF FRAMING-GABLE
STORY HEIGHT-0
STRUCTURAL FRAME-WOOD FRAME

 Areas - 1493 Total SF

BASE AREA - 1031
BASE SEMI FIN - 264
OPEN PORCH UNF - 66
WOOD DECK UNF - 132

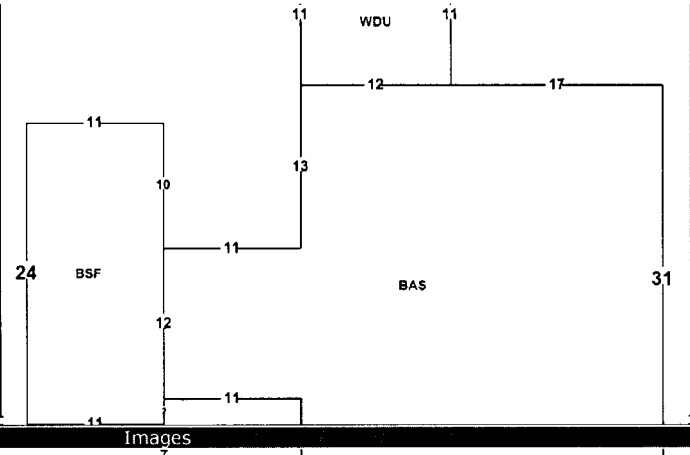

8/2/11

The primary use of the assessment data is for the preparation of the current year tax roll. No responsibility or liability is assumed for inaccuracies or errors.

Last Updated:04/20/2020 (tc.4717)

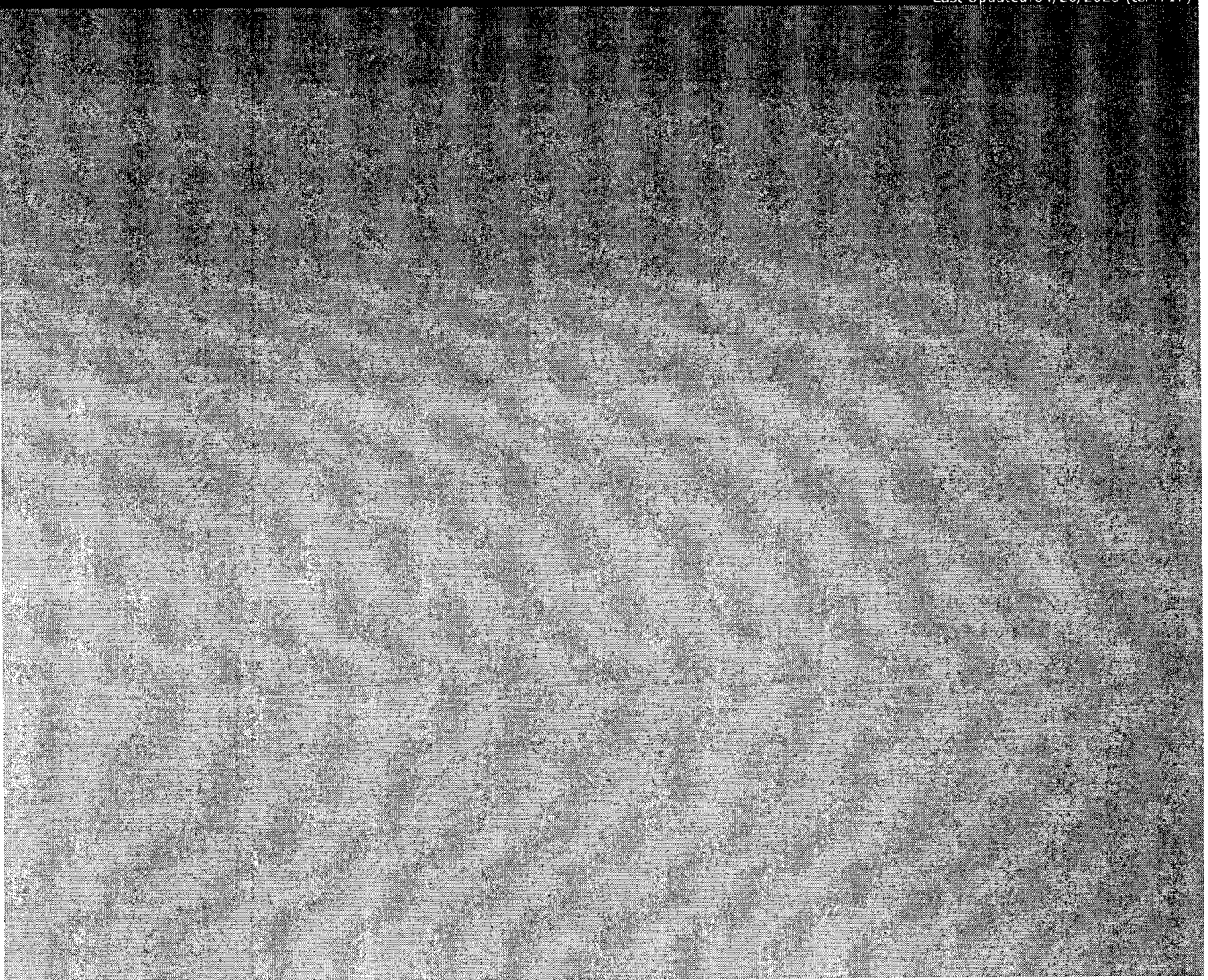

NOTICE OF APPLICATION FOR TAX DEED

NOTICE IS HEREBY GIVEN, That **ATCF II FLORIDA-A LLC** holder of **Tax Certificate No. 03903**, issued the **1st day of June, A.D., 2018** has filed same in my office and has made application for a tax deed to be issued thereon. Said certificate embraces the following described property in the County of Escambia, State of Florida, to wit:

LT 3 BLK 3 1ST ADDN TO EDGEWATER PB 3 P 6 OR 5801 P 995 CA 179

SECTION 37, TOWNSHIP 2 S, RANGE 30 W

TAX ACCOUNT NUMBER 073964000 (0321-09)

The assessment of the said property under the said certificate issued was in the name of

GRAAL PROPERTIES INC

Unless said certificate shall be redeemed according to law, the property described therein will be sold to the highest bidder at public auction at 9:00 A.M. on the **first Monday** in the month of **March**, which is the **1st day of March 2021**.

Dated this 29th day of April 2020.

In accordance with the AMERICANS WITH DISABILITIES ACT, if you are a person with a disability who needs special accommodation in order to participate in this proceeding you are entitled to the provision of certain assistance. Please contact Emily Hogg not later than seven days prior to the proceeding at Escambia County Government Complex, 221 Palafox Place Ste 110, Pensacola FL 32502. Telephone: 850-595-3793.



PAM CHILDERS
CLERK OF THE CIRCUIT COURT
ESCAMBIA COUNTY, FLORIDA

By:
Emily Hogg
Deputy Clerk

PAM CHILDERS
 CLERK OF THE CIRCUIT COURT
 ARCHIVES AND RECORDS
 CHILDSUPPORT
 CIRCUIT CIVIL
 CIRCUIT CRIMINAL
 COUNTY CIVIL
 COUNTY CRIMINAL
 DOMESTIC RELATIONS
 FAMILY LAW
 JURY ASSEMBLY
 JUVENILE
 MENTAL HEALTH
 MIS
 OPERATIONAL SERVICES
 PROBATE
 TRAFFIC



BRANCH OFFICES
ARCHIVES AND RECORDS
JUVENILE DIVISION
CENTURY

CLERK TO THE BOARD OF
 COUNTY COMMISSIONERS
 OFFICIAL RECORDS
 COUNTY TREASURY
 AUDITOR

COUNTY OF ESCAMBIA
OFFICE OF THE
CLERK OF THE CIRCUIT COURT

PAM CHILDERS, CLERK OF THE CIRCUIT COURT
Tax Certificate Redeemed From Sale
Account: 073964000 Certificate Number: 003903 of 2018

Payor: GRAAL PROPERTIES INC PO BOX 11697 PENSACOLA, FL 32524-1697 Date
 06/24/2020

Clerk's Check #	505324525	Clerk's Total	\$544.06
Tax Collector Check #	1	Tax Collector's Total	\$4,008.05
		Postage	\$60.00
		Researcher Copies	\$40.00
		Recording	\$10.00
		Prep Fee	\$7.00
		Total Received	\$4,669.11

3706.06

\$ 3,723.06

PAM CHILDERS
 Clerk of the Circuit Court

Received By: _____
 Deputy Clerk

PAM CHILDERS
 CLERK OF THE CIRCUIT COURT
 ARCHIVES AND RECORDS
 CHILDSUPPORT
 CIRCUIT CIVIL
 CIRCUIT CRIMINAL
 COUNTY CIVIL
 COUNTY CRIMINAL
 DOMESTIC RELATIONS
 FAMILY LAW
 JURY ASSEMBLY
 JUVENILE
 MENTAL HEALTH
 MIS
 OPERATIONAL SERVICES
 PROBATE
 TRAFFIC



BRANCH OFFICES
ARCHIVES AND RECORDS
JUVENILE DIVISION
CENTURY

CLERK TO THE BOARD OF
 COUNTY COMMISSIONERS
 OFFICIAL RECORDS
 COUNTY TREASURY
 AUDITOR

COUNTY OF ESCAMBIA
OFFICE OF THE
CLERK OF THE CIRCUIT COURT

Case # 2018 TD 003903

Redeemed Date 06/24/2020

Name GRAAL PROPERTIES INC PO BOX 11697 PENSACOLA, FL 32524-1697

Clerk's Total = TAXDEED	\$ 544.06	3,706.06
Due Tax Collector = TAXDEED	\$ 4,008.05	
Postage = TD2	\$60.00	
ResearcherCopies = TD6	\$40.00	
Release TDA Notice (Recording) = RECORD2	\$10.00	
Release TDA Notice (Prep Fee) = TD4	\$7.00	

• For Office Use Only

Date	Docket	Desc	Amount Owed	Amount Due	Payee Name
------	--------	------	-------------	------------	------------

FINANCIAL SUMMARY

No Information Available - See Dockets



PAM CHILDERS
CLERK OF THE CIRCUIT COURT
ESCAMBIA COUNTY, FLORIDA

Tax Deed - Redemption Calculator

Account: 073964000 Certificate Number: 003903 of 2018

Redemption Yes
 Application Date
 Interest Rate

	Final Redemption Payment ESTIMATED	Redemption Overpayment ACTUAL
	Auction Date <input type="text" value="03/01/2021"/>	Redemption Date <input type="text" value="06/24/2020"/>
Months	11	2
Tax Collector	<input type="text" value="\$3,429.66"/>	<input type="text" value="\$3,429.66"/>
Tax Collector Interest	\$565.89	\$102.89
Tax Collector Fee	<input type="text" value="\$12.50"/>	<input type="text" value="\$12.50"/>
Total Tax Collector	\$4,008.05	<input type="text" value="\$3,545.05"/> TC
Record TDA Notice	<input type="text" value="\$17.00"/>	<input type="text" value="\$17.00"/>
Clerk Fee	<input type="text" value="\$130.00"/>	<input type="text" value="\$130.00"/>
Sheriff Fee	<input type="text" value="\$120.00"/>	<input type="text" value="\$120.00"/>
Legal Advertisement	<input type="text" value="\$200.00"/>	<input type="text" value="\$200.00"/>
App. Fee Interest	\$77.06	\$14.01
Total Clerk	\$544.06	<input type="text" value="\$481.01"/> CH
Release TDA Notice (Recording)	<input type="text" value="\$10.00"/>	<input type="text" value="\$10.00"/>
Release TDA Notice (Prep Fee)	<input type="text" value="\$7.00"/>	<input type="text" value="\$7.00"/>
Postage	<input type="text" value="\$60.00"/>	<input type="text" value="\$0.00"/>
Researcher Copies	<input type="text" value="\$40.00"/>	<input type="text" value="\$0.00"/>
Total Redemption Amount	\$4,669.11	\$4,043.06
	Repayment Overpayment Refund Amount	\$626.05
Book/Page	<input type="text" value="8287"/>	<input type="text" value="352"/>

RELEASE OF NOTICE OF APPLICATION FOR TAX DEED

Pursuant to § 197.502(5)(c), Florida Statutes, the Escambia County Clerk of Court fully releases the Notice of Tax Deed Application recorded at Official Records Book 8287, Page 352, of Escambia County, for the tax certificate, tax deed, and property described below:

Tax Certificate No. Certificate No. 03903, issued the 1st day of June, A.D., 2018

TAX ACCOUNT NUMBER: 073964000 (0321-09)

DESCRIPTION OF PROPERTY:

LT 3 BLK 3 1ST ADDN TO EDGEWATER PB 3 P 6 OR 5801 P 995 CA 179

SECTION 37, TOWNSHIP 2 S, RANGE 30 W

NAME IN WHICH ASSESSED: GRAAL PROPERTIES INC

Dated this 25th day of June 2020.

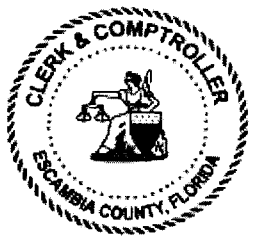

PAM CHILDERS
CLERK OF THE CIRCUIT COURT
ESCAMBIA COUNTY, FLORIDA

By:
Emily Hogg
Deputy Clerk



CERTIFICATION OF TAX DEED APPLICATION

Sections 197.502 and 197.542, Florida Statutes

DR-513
Rule 12D-16.002 F.A.C
Effective 07/19
Page 1 of 2

Part 1: Tax Deed Application Information					
Applicant Name Applicant Address	ATCF II FLORIDA-A, LLC PO BOX 69239 BALTIMORE, MD 21264-9239	Application date	Apr 07, 2020		
Property description	GRAAL PROPERTIES INC PO BOX 11697 PENSACOLA, FL 32524-1697 505 FRISCO RD 07-3964-000 LT 3 BLK 3 1ST ADDN TO EDGEWATER PB 3 P 6 OR 5801 P 995 CA 179	Certificate #	2018 / 3903		
		Date certificate issued	06/01/2018		
Part 2: Certificates Owned by Applicant and Filed with Tax Deed Application					
Column 1 Certificate Number	Column 2 Date of Certificate Sale	Column 3 Face Amount of Certificate	Column 4 Interest	Column 5: Total (Column 3 + Column 4)	
# 2018/3903	06/01/2018	988.57	49.43	1,038.00	
# 2019/3686	06/01/2019	1,024.47	51.22	1,075.69	
→Part 2: Total*				2,113.69	
Part 3: Other Certificates Redeemed by Applicant (Other than County)					
Column 1 Certificate Number	Column 2 Date of Other Certificate Sale	Column 3 Face Amount of Other Certificate	Column 4 Tax Collector's Fee	Column 5 Interest	Total (Column 3 + Column 4 + Column 5)
# /					
Part 3: Total*					0.00
Part 4: Tax Collector Certified Amounts (Lines 1-7)					
1. Cost of all certificates in applicant's possession and other certificates redeemed by applicant (<i>*Total of Parts 2 + 3 above</i>)				2,113.69	
2. Delinquent taxes paid by the applicant				0.00	
3. Current taxes paid by the applicant				940.97	
4. Property information report fee				200.00	
5. Tax deed application fee				175.00	
6. Interest accrued by tax collector under s.197.542, F.S. (see Tax Collector Instructions, page 2)				0.00	
7. Total Paid (Lines 1-6)				3,429.66	
I certify the above information is true and the tax certificates, interest, property information report fee, and tax collector's fees have been paid, and that the property information statement is attached.					
Sign here:			Escambia, Florida		
Signature, Tax Collector or Designee			Date <u>July 31st, 2020</u>		

Send this certification to the Clerk of Court by 10 days after the date signed. See Instructions on Page 2

Part 5: Clerk of Court Certified Amounts (Lines 8-14)	
8. Processing tax deed fee	
9. Certified or registered mail charge	
10. Clerk of Court advertising, notice for newspaper, and electronic auction fees	
11. Recording fee for certificate of notice	
12. Sheriff's fees	
13. Interest (see Clerk of Court Instructions, page 2)	
14. Total Paid (Lines 8-13)	
15. Plus one-half of the assessed value of homestead property, if applicable under s. 197.502(6)(c), F.S.	
16. Statutory opening bid (total of Lines 7, 14, 15, and 16 if applicable)	
Sign here: _____ Date of sale <u>03/01/2021</u>	
Signature, Clerk of Court or Designee	

INSTRUCTIONS + 12.50

Tax Collector (complete Parts 1-4)

Part 2: Certificates Owned by Applicant and Filed with Tax Deed Application

Enter the Face Amount of Certificate in Column 3 and the interest in Column 4 for each certificate number. Add Columns 3 and 4 and enter the amount in Column 5.

Part 3: Other Certificates Redeemed by Applicant (Other than County)

Total. Add the amounts in Columns 3, 4 and 5

Part 4: Tax Collector Certified Amounts (Lines 1-7)

Line 1, enter the total of Part 2 plus the total of Part 3 above.

Total Paid, Line 7: Add the amounts of Lines 1-6

Line 6, Interest accrued by tax collector. Calculate the 1.5 percent interest accrued from the month after the date of application through the month this form is certified to the clerk. Enter the amount to be certified to the clerk on Line 6. The interest calculated by the tax collector stops before the interest calculated by the clerk begins. See Section 197.542, F.S., and Rule 12D-13.060(3), Florida Administrative Code.

The tax collector's interest for redemption at the time of the tax deed application is a cost of redemption, which encompasses various percentages of interest on certificates and omitted or delinquent taxes under Section 197.502, F.S. This interest is calculated before the tax collector calculates the interest in Section 197.542, F.S.

Attach certified statement of names and addresses of persons who must be notified before the sale of the property. Send this form and any required attachments to the Clerk of Court within 10 days after it is signed.

Clerk of Court (complete Part 5)

Line 13: Interest is calculated at the rate of 1.5 percent per month starting from the first day of the month after the month of certification of this form through the last day of the month in which the sale will be held. Multiply the calculated rate by the total of Line 7, minus Line 6, plus Lines 8 through 12. Enter the amount on Line 13.

Line 14: Enter the total of Lines 8-13. Complete Lines 15-18, if applicable.