

# CERTIFICATION OF TAX DEED APPLICATION

Sections 197.502 and 197.542, Florida Statutes

0621-09

513  
R. 07/19

<b>Part 1: Tax Deed Application Information</b>					
Applicant Name Applicant Address	IDE IDE TECHNOLOGIES INC 3100 N29 COURT HOLLYWOOD, FL 33020	Application date	Apr 28, 2020		
Property description	STEWART MITCHELL G 104 E FRISCO RD PENSACOLA, FL 32507 104 FRISCO RD LT 55 BLK A EDGEWATER PB 2 P 97 OR 1903 P 364 OR 3533 P 566 SEC 37/38 2S 30 CA 162	Certificate #	2018 / 3874		
		Date certificate issued	06/01/2018		
		Deed application number	2000554		
		Account number	07-3685-000		
<b>Part 2: Certificates Owned by Applicant and Filed with Tax Deed Application</b>					
Column 1 Certificate Number	Column 2 Date of Certificate Sale	Column 3 Face Amount of Certificate	Column 4 Interest	Column 5: Total (Column 3 + Column 4)	
# 2018/3874	06/01/2018	262.12	86.50	348.62	
<b>→ Part 2: Total*</b>				<b>348.62</b>	
<b>Part 3: Other Certificates Redeemed by Applicant (Other than County)</b>					
Column 1 Certificate Number	Column 2 Date of Other Certificate Sale	Column 3 Face Amount of Other Certificate	Column 4 Tax Collector's Fee	Column 5 Interest	Total (Column 3 + Column 4 + Column 5)
# 2019/3651	06/01/2019	256.42	6.25	12.82	275.49
<b>Part 3: Total*</b>					<b>275.49</b>
<b>Part 4: Tax Collector Certified Amounts (Lines 1-7)</b>					
1. Cost of all certificates in applicant's possession and other certificates redeemed by applicant (*Total of Parts 2 + 3 above)				624.11	
2. Delinquent taxes paid by the applicant				0.00	
3. Current taxes paid by the applicant				219.12	
4. Property information report fee and Deed Application Recording and Release Fees				200.00	
5. Tax deed application fee				175.00	
6. Interest accrued by tax collector under s.197.542, F.S. (see Tax Collector Instructions, page 2)				0.00	
7. <b>Total Paid (Lines 1-6)</b>				<b>1,218.23</b>	
I certify the above information is true and the tax certificates, interest, property information report fee, and tax collector's fees have been paid, and that the property information statement is attached.					
Sign here:	<u>Escambia County</u> , Florida			Date <u>May 5th, 2020</u>	
Signature, Tax Collector or Designee					

Send this certification to the Clerk of Court by 10 days after the date signed. See Instructions on Page 2

<b>Part 5: Clerk of Court Certified Amounts (Lines 8-14)</b>	
8. Processing tax deed fee	
9. Certified or registered mail charge	
10. Clerk of Court advertising, notice for newspaper, and electronic auction fees	
11. Recording fee for certificate of notice	
12. Sheriff's fees	
13. Interest (see Clerk of Court Instructions, page 2)	
14. <b>Total Paid (Lines 8-13)</b>	
15. Plus one-half of the assessed value of homestead property, if applicable under s. 197.502(6)(c), F.S.	20,125.50
16. Other outstanding certificates and delinquent taxes not included in this Application, if applicable per Florida statutes	
17. Statutory opening bid (total of Lines 7, 14, 15, and 16 if applicable)	
18. Redemption fee	6.25
19. Total amount to redeem	
Sign here: _____ Date of sale <u>06/07/2021</u>	
Signature, Clerk of Court or Designee	

**INSTRUCTIONS**

**Tax Collector (complete Parts 1-4)**

**Part 2: Certificates Owned by Applicant and Filed with Tax Deed Application**

Enter the Face Amount of Certificate in Column 3 and the Interest in Column 4 for each certificate number. Add Columns 3 and 4 and enter the amount in Column 5.

**Part 3: Other Certificates Redeemed by Applicant (Other than County)**

**Total.** Add the amounts in Columns 3, 4 and 5

**Part 4: Tax Collector Certified Amounts (Lines 1-7)**

**Line 1,** enter the total of Part 2 plus the total of Part 3 above.

**Total Paid, Line 7:** Add the amounts of Lines 1-6

**Line 6, Interest accrued by tax collector.** Calculate the 1.5 percent interest accrued from the month after the date of application through the month this form is certified to the clerk. Enter the amount to be certified to the clerk on **Line 6.** The interest calculated by the tax collector stops before the interest calculated by the clerk begins. See Section 197.542, F.S., and Rule 12D-13.060(3), Florida Administrative Code.

The tax collector's interest for redemption at the time of the tax deed application is a cost of redemption, which encompasses various percentages of interest on certificates and omitted or delinquent taxes under Section 197.502, F.S. This interest is calculated before the tax collector calculates the interest in Section 197.542, F.S.

Attach certified statement of names and addresses of persons who must be notified before the sale of the property. Send this form and any required attachments to the Clerk of Court within 10 days after it is signed.

**Clerk of Court (complete Part 5)**

**Line 13: Interest** is calculated at the rate of 1.5 percent per month starting from the first day of the month after the month of certification of this form through the last day of the month in which the sale will be held. Multiply the calculated rate by the total of **Line 7,** minus **Line 6,** plus **Lines 8** through **12.** Enter the amount on **Line 13.**

**Line 14:** Enter the total of Lines 8-13. Complete Lines 15-18, if applicable.

# APPLICATION FOR TAX DEED

Section 197.502, Florida Statutes

512  
R. 12/16

Application Number: 2000554

To: Tax Collector of ESCAMBIA COUNTY, Florida

I,  
IDE  
IDE TECHNOLOGIES INC  
3100 N29 COURT  
HOLLYWOOD, FL 33020,

hold the listed tax certificate and hereby surrender the same to the Tax Collector and make tax deed application thereon:

Account Number	Certificate No.	Date	Legal Description
07-3685-000	2018/3874	06-01-2018	LT 55 BLK A EDGEWATER PB 2 P 97 OR 1903 P 364 OR 3533 P 566 SEC 37/38 2S 30 CA 162

I agree to:

- pay any current taxes, if due and
- redeem all outstanding tax certificates plus interest not in my possession, and
- pay all delinquent and omitted taxes, plus interest covering the property.
- pay all Tax Collector's fees, property information report costs, Clerk of the Court costs, charges and fees, and Sheriff's costs, if applicable.

Attached is the tax sale certificate on which this application is based and all other certificates of the same legal description which are in my possession.

Electronic signature on file  
IDE  
IDE TECHNOLOGIES INC  
3100 N29 COURT  
HOLLYWOOD, FL 33020

04-28-2020  
Application Date

\_\_\_\_\_  
Applicant's signature



# Chris Jones Escambia County Property Appraiser

Real Estate Search

Tangible Property Search

Sale List

← Navigate Mode  Account  Reference →

Printer Friendly Version

General Information	
Reference:	372S301000055001
Account:	073685000
Owners:	STEWART MITCHELL G
Mail:	104 E FRISCO RD PENSACOLA, FL 32507
Situs:	104 FRISCO RD 32507
Use Code:	SINGLE FAMILY RESID
Taxing Authority:	COUNTY MSTU
Tax Inquiry:	<a href="#">Open Tax Inquiry Window</a>
Tax Inquiry link courtesy of Scott Lunsford Escambia County Tax Collector	

Assessments				
Year	Land	Imprv	Total	Cap Val
2019	\$8,000	\$32,251	\$40,251	\$31,363
2018	\$8,000	\$31,497	\$39,497	\$30,779
2017	\$8,000	\$28,771	\$36,771	\$30,146

### Disclaimer

### Tax Estimator

> [File for New Homestead Exemption Online](#)

Sales Data					
Sale Date	Book	Page	Value	Type	Official Records (New Window)
03/1994	3533	566	\$3,500	QC	<a href="#">View Instr</a>
04/1984	1903	364	\$14,300	WD	<a href="#">View Instr</a>
10/1981	1603	18	\$14,000	WD	<a href="#">View Instr</a>
01/1973	702	314	\$11,360	SC	<a href="#">View Instr</a>
Official Records Inquiry courtesy of Pam Childers Escambia County Clerk of the Circuit Court and Comptroller					

2019 Certified Roll Exemptions	
HOMESTEAD EXEMPTION	

**Legal Description**  
 LT 55 BLK A EDGEWATER PB 2 P 97 OR 1903 P 364 OR  
 3533 P 566 SEC 37/38 2S 30 CA 162

**Extra Features**  
 None

### Parcel Information [Launch Interactive Map](#)

**Section Map Id:**  
CA162

**Approx. Acreage:**  
0.2032

**Zoned:**   
MDR

**Evacuation & Flood Information**  
[Open Report](#)

View Florida Department of Environmental Protection (DEP) Data

### Buildings

Address: 104 FRISCO RD, Year Built: 1952, Effective Year: 1952	
Structural Elements	
DECOR/MILLWORK-AVERAGE	
DWELLING UNITS-1	
EXTERIOR WALL-SIDING-BLW.AVG.	
FLOOR COVER-HARDWOOD/PARQUET	
FOUNDATION-WOOD/SUB FLOOR	
HEAT/AIR-WALL/FLOOR FURN	

**INTERIOR WALL-DRYWALL-PLASTER**  
**NO. PLUMBING FIXTURES-3**  
**NO. STORIES-1**  
**ROOF COVER-COMPOSITION SHG**  
**ROOF FRAMING-GABLE**  
**STORY HEIGHT-0**  
**STRUCTURAL FRAME-WOOD FRAME**

 Areas - 1089 Total SF

**BASE AREA - 763**  
**OPEN PORCH FIN - 110**  
**OPEN PORCH UNF - 156**  
**UTILITY UNF - 60**

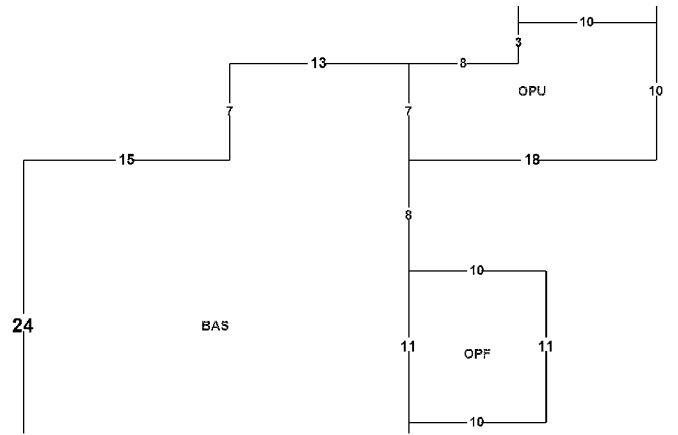

Images



04.16.2017 10:40:47

9/17/18

The primary use of the assessment data is for the preparation of the current year tax roll. No responsibility or liability is assumed for inaccuracies or errors.

## NOTICE OF APPLICATION FOR TAX DEED

NOTICE IS HEREBY GIVEN, That **IDE TECHNOLOGIES INC** holder of **Tax Certificate No. 03874**, issued the **1st day of June, A.D., 2018** has filed same in my office and has made application for a tax deed to be issued thereon. Said certificate embraces the following described property in the County of Escambia, State of Florida, to wit:

**LT 55 BLK A EDGEWATER PB 2 P 97 OR 1903 P 364 OR 3533 P 566 SEC 37/38 2S 30 CA 162**

**SECTION 37, TOWNSHIP 2 S, RANGE 30 W**

**TAX ACCOUNT NUMBER 073685000 (0621-09)**

The assessment of the said property under the said certificate issued was in the name of

**MITCHELL G STEWART**

Unless said certificate shall be redeemed according to law, the property described therein will be sold to the highest bidder at public auction at 9:00 A.M. on the **first Monday** in the month of June, which is the **7th day of June 2021**.

Dated this 15th day of June 2020.

In accordance with the AMERICANS WITH DISABILITIES ACT, if you are a person with a disability who needs special accommodation in order to participate in this proceeding you are entitled to the provision of certain assistance. Please contact Emily Hogg not later than seven days prior to the proceeding at Escambia County Government Complex, 221 Palafox Place Ste 110, Pensacola FL 32502. Telephone: 850-595-3793.



PAM CHILDERS  
CLERK OF THE CIRCUIT COURT  
ESCAMBIA COUNTY, FLORIDA

By:  
Emily Hogg  
Deputy Clerk

**PAM CHILDERS**  
 CLERK OF THE CIRCUIT COURT  
 ARCHIVES AND RECORDS  
 CHILDSUPPORT  
 CIRCUIT CIVIL  
 CIRCUIT CRIMINAL  
 COUNTY CIVIL  
 COUNTY CRIMINAL  
 DOMESTIC RELATIONS  
 FAMILY LAW  
 JURY ASSEMBLY  
 JUVENILE  
 MENTAL HEALTH  
 MIS  
 OPERATIONAL SERVICES  
 PROBATE  
 TRAFFIC

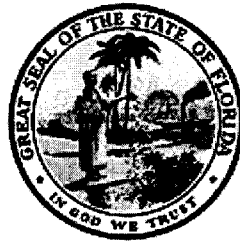

**BRANCH OFFICES**  
**ARCHIVES AND RECORDS**  
**JUVENILE DIVISION**  
**CENTURY**

CLERK TO THE BOARD OF  
 COUNTY COMMISSIONERS  
 OFFICIAL RECORDS  
 COUNTY TREASURY  
 AUDITOR

**COUNTY OF ESCAMBIA**  
**OFFICE OF THE**  
**CLERK OF THE CIRCUIT COURT**

**PAM CHILDERS, CLERK OF THE CIRCUIT COURT**  
**Tax Certificate Redeemed From Sale**  
**Account: 073685000 Certificate Number: 003874 of 2018**

**Payor: MITCHELL G STEWART 104 E FRISCO RD PENSACOLA, FL 32507      Date 07/09/2020**

Clerk's Check #	1	Clerk's Total	<del>\$565.07</del> 1447.32
Tax Collector Check #	1	Tax Collector's Total	<del>\$1,480.31</del>
		Postage	<del>\$60.00</del>
		Researcher Copies	<del>\$40.00</del>
		Recording	\$10.00
		Prep Fee	\$7.00
		Total Received	<del>\$2,162.38</del>

1464.32

**PAM CHILDERS**  
 Clerk of the Circuit Court

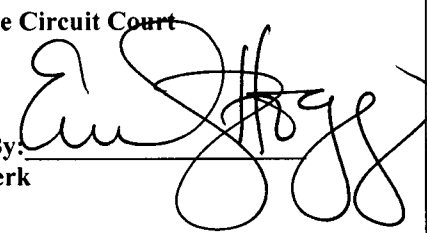
Received By:   
 Deputy Clerk

Escambia County Government Complex • 221 Palafox Place Ste 110 • PENSACOLA, FLORIDA 32502  
 (850) 595-3793 • FAX (850) 595-4827 • <http://www.clerk.co.escambia.fl.us>

**PAM CHILDERS**  
 CLERK OF THE CIRCUIT COURT  
 ARCHIVES AND RECORDS  
 CHILDSUPPORT  
 CIRCUIT CIVIL  
 CIRCUIT CRIMINAL  
 COUNTY CIVIL  
 COUNTY CRIMINAL  
 DOMESTIC RELATIONS  
 FAMILY LAW  
 JURY ASSEMBLY  
 JUVENILE  
 MENTAL HEALTH  
 MIS  
 OPERATIONAL SERVICES  
 PROBATE  
 TRAFFIC



**BRANCH OFFICES**  
**ARCHIVES AND RECORDS**  
**JUVENILE DIVISION**  
**CENTURY**

CLERK TO THE BOARD OF  
 COUNTY COMMISSIONERS  
 OFFICIAL RECORDS  
 COUNTY TREASURY  
 AUDITOR

**COUNTY OF ESCAMBIA**  
**OFFICE OF THE**  
**CLERK OF THE CIRCUIT COURT**

**Case # 2018 TD 003874**

**Redeemed Date 07/09/2020**

**Name MITCHELL G STEWART 104 E FRISCO RD PENSACOLA, FL 32507**

Clerk's Total = TAXDEED	\$565.07	1447.32
Due Tax Collector = TAXDEED	\$1480.31	
Postage = TD2	\$60.00	
ResearcherCopies = TD6	\$40.00	
Release TDA Notice (Recording) = RECORD2	\$10.00	
Release TDA Notice (Prep Fee) = TD4	\$7.00	

• For Office Use Only

Date	Docket	Desc	Amount Owed	Amount Due	Payee Name
------	--------	------	-------------	------------	------------

**FINANCIAL SUMMARY**

No Information Available - See Dockets





**PAM CHILDERS**  
**CLERK OF THE CIRCUIT COURT**  
**ESCAMBIA COUNTY, FLORIDA**

**Tax Deed - Redemption Calculator**

Account: 073685000 Certificate Number: 003874 of 2018

Redemption  No  Application Date  Interest Rate

	Final Redemption Payment ESTIMATED	Redemption Overpayment ACTUAL
	Auction Date <input type="text" value="06/07/2021"/>	Redemption Date <input type="text" value="07/09/2020"/>
Months	14	3
Tax Collector	<input type="text" value="\$1,218.23"/>	<input type="text" value="\$1,218.23"/>
Tax Collector Interest	\$255.83	\$54.82
Tax Collector Fee	<input type="text" value="\$6.25"/>	<input type="text" value="\$6.25"/>
<b>Total Tax Collector</b>	\$1,480.31	<u>\$1,279.30</u> TC
Record TDA Notice	<input type="text" value="\$17.00"/>	<input type="text" value="\$17.00"/>
Clerk Fee	<input type="text" value="\$130.00"/>	<input type="text" value="\$130.00"/>
Sheriff Fee	<input type="text" value="\$120.00"/>	<input type="text" value="\$120.00"/>
Legal Advertisement	<input type="text" value="\$200.00"/>	<input type="text" value="\$200.00"/>
App. Fee Interest	\$98.07	\$21.02
<b>Total Clerk</b>	\$565.07	<u>\$488.02</u> CH
Release TDA Notice (Recording)	<input type="text" value="\$10.00"/>	<input type="text" value="\$10.00"/>
Release TDA Notice (Prep Fee)	<input type="text" value="\$7.00"/>	<input type="text" value="\$7.00"/>
Postage	<input type="text" value="\$60.00"/>	<input type="text" value="\$0.00"/>
Researcher Copies	<input type="text" value="\$40.00"/>	<input type="text" value="\$0.00"/>
<b>Total Redemption Amount</b>	\$2,162.38	\$1,784.32
	Repayment Overpayment Refund Amount	\$378.06
Book/Page	<input type="text" value="8312"/>	<input type="text" value="1962"/>

## RELEASE OF NOTICE OF APPLICATION FOR TAX DEED

Pursuant to § 197.502(5)(c), Florida Statutes, the Escambia County Clerk of Court fully releases the Notice of Tax Deed Application recorded at Official Records Book 8312, Page 1962, of Escambia County, for the tax certificate, tax deed, and property described below:

Tax Certificate No. Certificate No. 03874, issued the 1st day of June, A.D., 2018

TAX ACCOUNT NUMBER: 073685000 (0621-09)

DESCRIPTION OF PROPERTY:

LT 55 BLK A EDGEWATER PB 2 P 97 OR 1903 P 364 OR 3533 P 566 SEC 37/38 2S 30 CA 162

SECTION 37, TOWNSHIP 2 S, RANGE 30 W

NAME IN WHICH ASSESSED: MITCHELL G STEWART

Dated this 9th day of July 2020.



PAM CHILDERS  
CLERK OF THE CIRCUIT COURT  
ESCAMBIA COUNTY, FLORIDA

By:  
Emily Hogg  
Deputy Clerk



# CERTIFICATION OF TAX DEED APPLICATION

Sections 197.502 and 197.542, Florida Statutes

DR-513  
Rule 12D-16.002 F.A.C  
Effective 07/19  
Page 1 of 2

<b>Part 1: Tax Deed Application Information</b>					
Applicant Name Applicant Address	IDE IDE TECHNOLOGIES INC 3100 N29 COURT HOLLYWOOD, FL 33020	Application date	Apr 28, 2020		
Property description	STEWART MITCHELL G 104 E FRISCO RD PENSACOLA, FL 32507 104 FRISCO RD 07-3685-000 LT 55 BLK A EDGEWATER PB 2 P 97 OR 1903 P 364 OR 3533 P 566 SEC 37/38 2S 30 CA 162	Certificate #	2018 / 3874		
		Date certificate issued	06/01/2018		
<b>Part 2: Certificates Owned by Applicant and Filed with Tax Deed Application</b>					
Column 1 Certificate Number	Column 2 Date of Certificate Sale	Column 3 Face Amount of Certificate	Column 4 Interest	Column 5: Total (Column 3 + Column 4)	
# 2018/3874	06/01/2018	262.12	86.50	348.62	
<b>→Part 2: Total*</b>				<b>348.62</b>	
<b>Part 3: Other Certificates Redeemed by Applicant (Other than County)</b>					
Column 1 Certificate Number	Column 2 Date of Other Certificate Sale	Column 3 Face Amount of Other Certificate	Column 4 Tax Collector's Fee	Column 5 Interest	Total (Column 3 + Column 4 + Column 5)
# 2019/3651	06/01/2019	256.42	6.25	12.82	275.49
<b>Part 3: Total*</b>					<b>275.49</b>
<b>Part 4: Tax Collector Certified Amounts (Lines 1-7)</b>					
1. Cost of all certificates in applicant's possession and other certificates redeemed by applicant (*Total of Parts 2 + 3 above)				624.11	
2. Delinquent taxes paid by the applicant				0.00	
3. Current taxes paid by the applicant				219.12	
4. Property information report fee				200.00	
5. Tax deed application fee				175.00	
6. Interest accrued by tax collector under s.197.542, F.S. (see Tax Collector Instructions, page 2)				0.00	
7. <b>Total Paid (Lines 1-6)</b>				<b>1,218.23</b>	
I certify the above information is true and the tax certificates, interest, property information report fee, and tax collector's fees have been paid, and that the property information statement is attached.					
Sign here:  _____			Escambia, Florida		
Signature, Tax Collector or Designee			Date <u>August 26th, 2020</u>		

*Send this certification to the Clerk of Court by 10 days after the date signed. See Instructions on Page 2*

<b>Part 5: Clerk of Court Certified Amounts (Lines 8-14)</b>	
8. Processing tax deed fee	
9. Certified or registered mail charge	
10. Clerk of Court advertising, notice for newspaper, and electronic auction fees	
11. Recording fee for certificate of notice	
12. Sheriff's fees	
13. Interest (see Clerk of Court Instructions, page 2)	
14. <b>Total Paid (Lines 8-13)</b>	
15. Plus one-half of the assessed value of homestead property, if applicable under s. 197.502(6)(c), F.S.	15,681.50
16. Statutory opening bid (total of Lines 7, 14, 15, and 16 if applicable)	
Sign here: _____ Date of sale <u>06/07/2021</u> Signature, Clerk of Court or Designee	

**INSTRUCTIONS** *+ 6.25*

**Tax Collector (complete Parts 1-4)**

**Part 2: Certificates Owned by Applicant and Filed with Tax Deed Application**

Enter the Face Amount of Certificate in Column 3 and the Interest in Column 4 for each certificate number. Add Columns 3 and 4 and enter the amount in Column 5.

**Part 3: Other Certificates Redeemed by Applicant (Other than County)**

**Total.** Add the amounts in Columns 3, 4 and 5

**Part 4: Tax Collector Certified Amounts (Lines 1-7)**

**Line 1,** enter the total of Part 2 plus the total of Part 3 above.

**Total Paid, Line 7:** Add the amounts of Lines 1-6

**Line 6, Interest accrued by tax collector.** Calculate the 1.5 percent interest accrued from the month after the date of application through the month this form is certified to the clerk. Enter the amount to be certified to the clerk on **Line 6**. The interest calculated by the tax collector stops before the interest calculated by the clerk begins. See Section 197.542, F.S., and Rule 12D-13.060(3), Florida Administrative Code.

The tax collector's interest for redemption at the time of the tax deed application is a cost of redemption, which encompasses various percentages of interest on certificates and omitted or delinquent taxes under Section 197.502, F.S. This interest is calculated before the tax collector calculates the interest in Section 197.542, F.S.

Attach certified statement of names and addresses of persons who must be notified before the sale of the property. Send this form and any required attachments to the Clerk of Court within 10 days after it is signed.

**Clerk of Court (complete Part 5)**

**Line 13: Interest** is calculated at the rate of 1.5 percent per month starting from the first day of the month after the month of certification of this form through the last day of the month in which the sale will be held. Multiply the calculated rate by the total of **Line 7**, minus **Line 6**, plus **Lines 8** through **12**. Enter the amount on **Line 13**.

**Line 14:** Enter the total of Lines 8-13. Complete Lines 15-18, if applicable.



**PROPERTY INFORMATION REPORT**  
3050 Concho Drive, Pensacola, Florida 32507 | Phone: 850-466-3077

THE ATTACHED REPORT IS ISSUED TO:

SCOTT LUNSFORD, ESCAMBIA COUNTY TAX COLLECTOR

TAX ACCOUNT #: 07-3685-000 CERTIFICATE #: 2018-3874

THIS REPORT IS NOT TITLE INSURANCE. THE LIABILITY FOR ERRORS OR OMISSIONS IN THIS REPORT IS LIMITED TO THE PERSON(S) EXPRESSLY IDENTIFIED BY NAME IN THE PROPERTY INFORMATION REPORT AS THE RECIPIENT(S) OF THE PROPERTY INFORMATION REPORT.

The attached Report prepared in accordance with the instructions given by the user named above includes a listing of the owner(s) of record of the land described herein together with current and delinquent ad valorem tax information and a listing and copies of all open or unsatisfied leases, mortgages, judgments, and encumbrances recorded in the Official Record Books of Escambia County, Florida that appear to encumber the title to said land as listed on page 2 herein. It is the responsibility of the party named above to verify receipt of each document listed. If a copy of any document listed is not received, the office issuing this Report must be contacted immediately.

**This Report is subject to:** Current year taxes; taxes and assessments due now or in subsequent years; oil, gas, and mineral or any subsurface rights of any kind or nature; easements, restrictions, and covenants of record; encroachments, overlaps, boundary line disputes, and any other matters that would be disclosed by an accurate survey and inspection of the premises.

This Report does not insure or guarantee the validity or sufficiency of any document attached, nor is it to be considered a title insurance policy, an opinion of title, a guarantee of title, or as any other form of guarantee or warranty of title.

Use of the term "Report" herein refers to the Property Information Report and the documents attached hereto.

Period Searched: March 18, 2001 to and including March 18, 2021 Abstractor: Cody Campbell

BY

Michael A. Campbell,  
As President  
Dated: March 29, 2021

**PROPERTY INFORMATION REPORT**  
**CONTINUATION PAGE**

March 29, 2021

Tax Account #: 07-3685-000

1. The Grantee(s) of the last deed(s) of record is/are: **MITCHELL G. STEWART**

**By Virtue of Warranty Deed recorded 04/26/1984 – OR 1903/364, together with Quit Claim Deed recorded 11/25/1994 – OR 3533/566**

2. The land covered by this Report is:

**See attached Exhibit “A”**

3. The following unsatisfied mortgages, liens, and judgments affecting the land covered by this Report appear of record:

- a. **Judgment in favor of Monsanto Employees Credit Union recorded 03/05/2003 – OR 5082/1098**
- b. **Fire Protection MSBU Lien in favor of the State of Florida / Escambia County recorded 10/05/1998 – OR 4316/1951**
- c. **Fire Protection MSBU Lien in favor of the State of Florida / Escambia County recorded 08/12/1999 – OR 4452/475**

4. Taxes:

**Taxes for the year(s) 2017-2019 are delinquent.**

**Tax Account #:07-3685-000**

**Assessed Value: \$32,084**

**Exemptions: HOMESTEAD EXEMPTION**

5. We find the following HOA names in our search (if a condominium, the condo docs book and page are included for your review): **NONE**

Payment of any special liens/assessments imposed by City, County, and/or State.

Note: Escambia County and/or local municipalities may impose special liens/assessments. These liens/assessments are not discovered in a title search or shown above. These special assessments typically create a lien on real property. The entity that governs subject property must be contacted to verify payment status.



**March 29, 2021**

**Tax Account #:07-3685-000**

**LEGAL DESCRIPTION  
EXHIBIT "A"**

**LT 55 BLK A EDGEWATER PB 2 P 97 OR 1903 P 364 OR 3533 P 566 SEC 37/38 2S 30 CA 162**

**SECTION 37, TOWNSHIP 2 S, RANGE 30 W**

**TAX ACCOUNT NUMBER 07-3685-000 (0621-09)**



THIS INSTRUMENT PREPARED BY  
TOMMY E. MCPHERSON, ESQUIRE  
Attorney at Law  
601 New Warrington Road  
Pensacola, Florida 32506  
Telephone (904) 453-9549

executive line

# This Indenture,

1903 PAGE 364

(The terms "grantor" and "grantee" herein shall be construed to include all grantors and grantees or plural as the context indicates.)

Made this 25th day of April, 1984, Between

MICHAEL C. SMITH and DEBORA L. SMITH, Husband & Wife,

of the County of Escambia, State of Florida, grantor, and

MITCHELL G. STEWART and YVONNE S. STEWART, Husband & Wife,

whose post-office address is 104 Frisco Road, Pensacola 32507  
of the County of Escambia, State of Florida, grantee.

**Witnesseth:** That said grantor, for and in consideration of the sum of TEN & NO/100 (\$10.00) -- Dollars, and other good and valuable considerations to said grantor in hand paid by said grantee, the receipt whereof is hereby acknowledged, has granted, bargained and sold to the said grantee, and grantee's heirs, successors and assigns forever, the following described land, situate, lying and being in Escambia County, Florida, to wit

Lot 55, Block A, Edgewater Subdivision, a subdivision of a portion of Sections 37 and 38, Township 2 South, Range 30 West, Escambia County, Florida, according to plat of said subdivision, recorded in Plat Book 2 at page 97 of the public records of said County.

Subject to a mortgage to WENDELL SIMMONS and MAVIS SIMMONS, Husband and Wife, dated October 30, 1981, and filed on November 3, 1981, in O.R. Book 1590, Page 271, Public Records of Escambia County, Florida, in the original sum of \$14,000.00, which sum Grantees expressly assume and agree to pay.

Grantees assume taxes for 1984 and subsequent years.

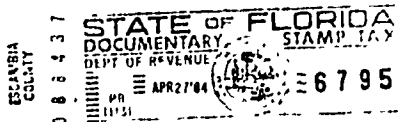

APR 26 1984  
200786

and said grantor does hereby fully warrant the title to said land, and will defend the same against the lawful claims of all persons whomsoever

**In Witness Whereof,** Grantor has hereunto set grantor's hand and seal the day and year first above written  
Signed, sealed and delivered in our presence

*Tommy E. McPherson*  
*Robt. M. McPherson*

*Michael C. Smith* (Seal)  
MICHAEL C. SMITH  
*Deborah L. Smith* (Seal)  
DEBORA L. SMITH (Seal)

STATE OF FLORIDA  
COUNTY OF ESCAMBIA

I HEREBY CERTIFY that on this day before me, an officer duly qualified to take acknowledgments, personally appeared

MICHAEL C. SMITH and DEBORA L. SMITH, Husband & Wife,

to me known to be the person(s) described in and who executed the foregoing instrument and acknowledged before me the execution of same

WITNESS my hand and official seal in the County and State last aforesaid this 25th day of April, 1984.

*Robt. M. McPherson*  
Notary Public  
My commission expires 11-7-87

QUIT-CLAIM DEED

RAMCO FORM 8

Return to: (enclose self-addressed stamped envelope)

Name: Mitchell G. Stewart  
104 Frisco Road  
Pensacola, FL 32507

30.50  
24.50  
50

This instrument Prepared by:

Address: Tommy E. McPherson, Esquire  
601 New Warrington Road  
Pensacola, FL 32506

Property Appraisers Parcel Identification (Folio) Number(s):

Grantee(s) S.S. #(s):

©Scanned Paper & Printing Co., Inc. 1987

OR BOOK 3533 PG 566

FILED & RECORDED  
PUBLIC RECORDS OFFICE  
ESCAMBIA CO FL 09  
MAR 7 11 25 AM '94  
IN BOOK & PAGE NOTED  
ABOVE - RECORD VERIFIED  
JOE A. FLOWERS  
COMPTROLLER  
ESCAMBIA COUNTY

110748

SPACE ABOVE THIS LINE FOR PROCESSING DATA

SPACE ABOVE THIS LINE FOR RECORDING DATA

This Quit-Claim Deed, Executed this 7th day of March, A.D. 1994, by

YVONNE S. STEWART, a single woman  
first party, to

MITCHELL G. STEWART, a single man  
whose post office address is

104 Frisco Road, Pensacola, FL 32507  
second party:

(Wherever used herein the terms "first party" and "second party" shall include singular and plural, heirs, legal representatives, and assigns of individuals, and the successors and assigns of corporations, wherever the context so admits or requires.)

Witnesseth, That the said first party, for and in consideration of the sum of \$ 10.00-----, in hand paid by the said second party, the receipt whereof is hereby acknowledged, does hereby remise, release and quit-claim unto the said second party forever, all the right, title, interest, claim and demand which the said first party has in and to the following described lot, piece or parcel of land, situate, lying and being in the County of Escambia, State of Florida, to-wit:

Lot 55, Block A, Edgewater Subdivision, a subdivision of a portion of Sections 37 and 38, Township 2 South, Range 30 West, Escambia County, Florida, according to plat of said subdivision, recorded in Plat Book 2 at Page 97 of the public records of said County.

D.S. PD. \$ 24.50  
DATE Mar. 7, 1994  
JOE A. FLOWERS, COMPTROLLER  
BY: Robin M. McPherson D.C.  
CERT. REG. #59-2043328-27-01

To Have and to Hold The same together with all and singular the appurtenances thereunto belonging on in anywise appertaining, and all the estate, right, title, interest, lien, equity and claim whatsoever of the said first party, either in law or equity, to the only proper use, benefit and behoof of the said second party forever.

In Witness Whereof, The said first party has signed and sealed these presents the day and year first above written.

Signed, sealed and delivered in the presence of:

Tommy E. McPherson  
Witness Signature (as to first Grantor)  
TOMMY E. MCPHERSON  
Printed Name

Cynthia J. Gordon  
Witness Signature (as to first Grantor)  
CYNTHIA J. GORDON  
Printed Name

Yvonne S. Stewart  
Grantor Signature  
YVONNE S. STEWART  
Printed Name  
104 Frisco Rd, Pensacola, FL 32507  
Post Office Address  
FL DL# K530-977-40-565

Witness Signature (as to second Grantor, if any)

Printed Name

Witness Signature (as to second Grantor, if any)

Printed Name

STATE OF FLORIDA  
COUNTY OF ESCAMBIA

I HEREBY CERTIFY that on this day, before me, an officer duly authorized in the State aforesaid and in the County aforesaid to take acknowledgments, personally appeared YVONNE S. STEWART

to me known to be the person described in and who she acknowledged before me that she executed the same, upon oath.

WITNESS my hand and official seal in the County and State last aforesaid this 7th day of March, A.D. 1994.



ROBIN M. MCPHERSON  
MY COMMISSION # CC 157145 EXPIRES  
November 7, 1995  
BONDED THRU TROY FAIR INSURANCE, INC.

Robin M. McPherson  
Notary Signature  
ROBIN M. MCPHERSON  
Printed Notary Signature  
My Commission Expires: 11-7-95

OR Bk4003 Pg0309

INSTRUMENT 00306938

OR BK 5082 PG1098

Escambia County, Florida

INSTRUMENT 2003-066475

IN THE COUNTY COURT IN AND FOR ESCAMBIA COUNTY, FLORIDA

Nonsanto Employer Credit Union  
P. O. Box 12990  
Pensacola, FL 32591

RCD Mar 05, 2003 10:38 am  
Escambia County, Florida

Plaintiff,

ERNIE LEE MAGAHA  
Clerk of the Circuit Court  
INSTRUMENT 2003-066475

vs:

FINAL JUDGMENT AS TO  
MITCHELL G. STEWART

Mitchell G. Stewart  
104 Frisco Drive  
Pensacola, FL 32507

Case No. 88-4770-SP-11

Defendant,

THE Plaintiff(s) Nonsanto Employees Credit Union, hereby  
recover(s) from the Defendant(s) Mitchell G. Stewart, the  
sum of \$1,416.36 plus costs of \$0.00 for a total of \$1,416.36,  
that shall bear interest at the rate of 12% per year, all for which  
let execution issue.

DONE AND ORDERED in Chambers, at Pensacola, Escambia  
County, Florida, this 5th day of September 1989.

*[Signature]*  
County Judge

Copies to:  
Plaintiff  
Defendant

Certified to be a true copy of  
the original on file in this office  
Witness my hand and official seal  
ERNIE LEE MAGAHA  
Clerk of the Circuit Court  
Escambia County Florida  
By *[Signature]* D.C.  
Date: MAR 04 2003



741882  
NO 11  
COURT IN  
ORDER OF  
FILED IN  
SEP 6 2 51 PM '89

Certified to be a true copy of the  
original on file in this office.  
Witness my hand and official seal  
ERNIE LEE MAGAHA  
Clerk Circuit Court and County Court  
Escambia County, Florida  
By *[Signature]* D.C.

Instrument 00306938  
Filed and recorded in the  
Official Records  
JULY 1, 1986  
at 02:57 P.M.  
ERNIE LEE MAGAHA,  
CLERK OF THE CIRCUIT COURT  
Escambia County,  
Florida

CLERK OF THE CIRCUIT COURT  
BY *[Signature]*  
DEPUTY CLERK

OR BK 5082 P61097  
Escambia County, Florida  
INSTRUMENT 2003-066474  
RCD Mar 05, 2003 10:38 am  
Escambia County, Florida

**IN THE CIRCUIT COURT IN AND FOR ESCAMBIA COUNTY, FLORIDA**

**ERNIE LEE MAGAHA**  
Clerk of the Circuit Court  
INSTRUMENT 2003-066474

Monsanto Employees Credit Union,  
Plaintiff,

vs.

**Case No. 88-4770-SP-11**

Mitchell G. Stewart

Defendant

STATE OF FLORIDA  
COUNTY OF ESCAMBIA

**ADDRESS AFFIDAVIT**

Before me, the undersigned authority, personally appeared Priscilla Lewis, who, after being duly sworn, deposes and says:

1. That she is a Collections Officer at MONSANTO EMPLOYEES CREDIT UNION.
2. That the mailing address if MONSANTO EMPLOYEES CREDIT UNION IS:  
**220 East Nine Mile Rd., Pensacola, FL 32534.**
3. That MONSANTO EMPLOYEES CREDIT UNION is the owner and holder of that final judgment entered against **Mitchell G. Stewart on September 5, 1989** in this case.

FURTHER AFFIANT SAYETH NAUGHT.



STATE OF FLORIDA  
COUNTY OF ESCAMBIA

Priscilla Lewis

The forgoing instrument was acknowledged before me this **12th day of February, 2003**, by Priscilla Lewis, who is personally known to me.

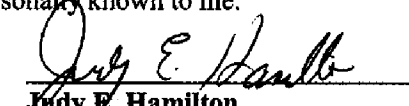
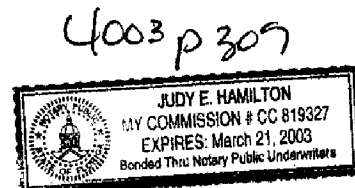
  
**Judy E. Hamilton**  
Notary Public

OR BK 4316 PG1951  
Escambia County, Florida  
INSTRUMENT 98-532228

NOTICE OF LIEN

RCD Oct 05, 1998 03:17 pm  
Escambia County, Florida

STATE OF FLORIDA  
COUNTY OF ESCAMBIA

Ernie Lee Magaha  
Clerk of the Circuit Court  
INSTRUMENT 98-532228

FIRE PROTECTION MUNICIPAL SERVICE BENEFIT UNIT (MSBU)

Re: STEWART MITCHELL G  
104 E FRISCO RD  
PENSACOLA FL 32507

ACCT.NO. 07 3685 000 000  
AMOUNT \$411.40

THIS Notice of Lien is hereby filed pursuant to Section 1-15-63 of the Escambia County, Florida Code of Ordinances for delinquent annual assessments for fiscal years prior to and including September 30, 1998 plus a 10% penalty charge against real property, more particularly described as:

LOT 55 BLK A  
EDGEWATER PB 2 P 97  
SEC 37/38 2S 30  
OR 1903 P 364  
CA 162  
OR 353? P 566  
PROP.NO. 37 2S 30 1000 055 001

filed in the public records of Escambia County. This constitutes a lien against the property identified above until discharged and satisfied by payment to the Clerk of the Circuit Court of the lien, plus penalties, in the total amount of \$411.40. Evidence of discharge and satisfaction of this lien can be recorded in the public records of Escambia County, Florida by the Clerk of the Circuit Court.

This lien shall not be assigned to any person. Until fully satisfied by payment, discharged or barred by law, this lien shall remain equal in rank and dignity with the liens of all state, county, district or municipal taxes and special assessments and superior in rank and dignity to all other subsequently filed liens, encumbrances, titles and claims in, to, or against the property. This lien may be enforced at any time by the Board of County Commissioners subsequent to the date of recording of this Notice of Lien for the amount due under the recorded lien, including all penalties, plus costs and a reasonable attorney's fee by proceedings in a court of equity to foreclose liens in the manner in which a mortgage lien is foreclosed or under the provisions of Chapter 173, Florida Statutes or the collection and enforcement of payment thereof may be accomplished by any other method authorized by law.

Date: 09/04/1998



Ernie Lee Magaha  
Clerk of the Circuit Court

*Frank M. McCreary*  
Deputy Finance Director

Ernie Lee Magaha  
Clerk of the Circuit Court

*Barbara B. Donnelly*  
Deputy Clerk

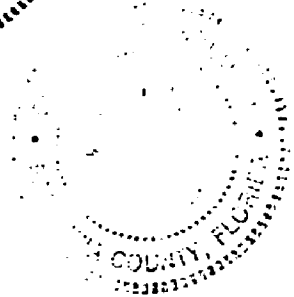

OR BK 4452 P60475  
Escambia County, Florida  
INSTRUMENT 99-643975

RCD Aug 12, 1999 07:58 am  
Escambia County, Florida

NOTICE OF LIEN

Ernie Lee Magaha  
Clerk of the Circuit Court  
INSTRUMENT 99-643975

STATE OF FLORIDA  
COUNTY OF ESCAMBIA

FIRE PROTECTION MUNICIPAL SERVICE BENEFIT UNIT(MSBU)

Re: STEWART MITCHELL G  
104 E FRISCO RD  
PENSACOLA FL 32507

ACCT.NO. 07 3685 000 000  
AMOUNT \$35.20

THIS Notice of Lien is hereby filed pursuant to Section 1-15-63 of the Escambia County, Florida Code of Ordinances for delinquent annual assessments for the fiscal year October 1, 1998 through September 30, 1999 plus a 10% penalty charge against real property, more particularly described as:

LT 55 BLK A  
EDGEWATER  
PB 2 P 97  
OR 1903 P 364 OR 3533 P 566  
SEC 37/38 2S 30  
CA 162  
PROP.NO. 37 2S 30 1000 055 001

filed in the public records of Escambia County. This constitutes a lien against the property identified above until discharged and satisfied by payment to the Clerk of the Circuit Court of the lien, plus penalties, in the total amount of \$35.20. Evidence of discharge and satisfaction of this lien can be recorded in the public records of Escambia County, Florida by the Clerk of the Circuit Court.

This lien shall not be assigned to any person. Until fully satisfied by payment, discharged or barred by law, this lien shall remain equal in rank and dignity with the liens of all state, county, district or municipal taxes and special assessments and superior in rank and dignity to all other subsequently filed liens, encumbrances, titles and claims in, to, or against the property. This lien may be enforced at any time by the Board of County Commissioners subsequent to the date of recording of this Notice of Lien for the amount due under the recorded lien, including all penalties, plus costs and a reasonable attorney's fee by proceedings in a court of equity to foreclose liens in the manner in which a mortgage lien is foreclosed or under the provisions of Chapter 178, Florida Statutes or the collection and enforcement of payment thereof may be accomplished by any other method authorized by law.

Date: 05/24/1999

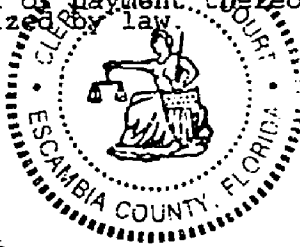

Ernie Lee Magaha  
Clerk of the Circuit Court

Wanda M. McRearty  
Deputy Finance Director

Ernie Lee Magaha  
Clerk of the Circuit Court

by: *Georgianne B. Donnelly*  
Deputy Clerk

