

19-451

Tax Collector's Certification

CTY-513

Tax Deed Application Number
1900193

Date of Tax Deed Application
Apr 17, 2019

This is to certify that **AFFILIATED TAX CO LLC - 17 US BANK % AFFILIATED TAX CO LL**, holder of **Tax Sale Certificate Number 2017 / 1324**, Issued the 1st Day of June, 2017 and which encumbers the following described property in the county of Escambia County , State of Florida, to wit: **03-1994-130**

Cert Holder:
AFFILIATED TAX CO LLC - 17 US BANK % AFFILIATED TAX CO LL
PO BOX 645040
CINCINNATI, OH 45264-5040

Property Owner:
HEALY BETTY JO LIFE ESTATE & HEALY BETTY JO TRUSTEE
6366 APPOMATTOX DR
PENSACOLA, FL 32503
LT 19 BLK 7 OAKFIELD ACRES PARCEL 7 PB 6 P 82 OR 917 P 64
OR 4308 P 632 OR 6107 P 1924

has surrendered same in my office and made written application for tax deed in accordance with Florida Statutes. I certify that the following tax certificates, interest, ownership and encumbrance report fee, and Tax Collector's fees have been paid, or if the certificate is held by the County, all appropriate fees have been deposited.

Certificates owned by applicant and filed in connection with this application:

Certificate Year/Number	Account Number	Sale Date	Face Amount of Certificate	Interest	Total
2017/1324	03-1994-130	06/01/2017	3,570.08	178.50	3,748.58

Certificates redeemed by applicant or included (County) in connection with this tax deed application:

Certificate Year/Number	Account Number	Sale Date	Face Amount of Certificate	Tax Collector's Fee	Interest	Total
/						

Amounts Certified by Tax Collector (Lines 1-7):

Total Amount Paid

1. Total of all Certificates in Applicant's Possession and Cost of the Certificates Redeemed by Applicant	3,748.58
2. Total of Delinquent Taxes Paid by Tax Deed Applicant	0.00
3. Total of Current Taxes Paid by Tax Deed Applicant	0.00
4. Property Information Report Fee	200.00
5. Tax Deed Application Fee	175.00
6. Total Interest Accrued by Tax Collector Pursuant to Section 197.542, F.S.	
7. Total (Lines 1 - 6)	4,123.58

Amounts Certified by Clerk of Court (Lines 8-15):

Total Amount Paid

8. Clerk of Court Statutory Fee for Processing Tax Deed	
9. Clerk of Court Certified Mail Charge	
10. Clerk of Court Advertising Charge	
11. Clerk of Court Recording Fee for Certificate of Notice	
12. Sheriff's Fee	
13. Interest Computed by Clerk of Court Pursuant to Section 197.542, F.S.	
14. Total (Lines 8 - 13)	
15. One-half Assessed Value of Homestead Property, if Applicable per F.S.	
16. Other Outstanding Certificates and Delinquent Taxes Not Included in this Application,	
17. Statutory (Opening) Bid; Total of Lines 7, 14, 15 (if applicable) and 16 (if	
18. Redemption Fee	6.25
19. Total Amount to Redeem	

Done this the 24th day of April, 2019 Scott Lunsford, Tax Collector of Escambia County

Date of Sale: 9-3-19

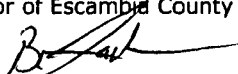
By 

*This certification must be surrendered to the Clerk of the Circuit Court no later than ten (10) days after this date.
03-1994-130 2017

APPLICATION FOR TAX DEED

Section 197.502, Florida Statutes

512
R. 12/16

Application Number: 1900193

To: Tax Collector of ESCAMBIA COUNTY, Florida

I,
AFFILIATED TAX CO LLC - 17 US BANK % AFFILIATED TAX CO LL
PO BOX 645040
CINCINNATI, OH 45264-5040,

hold the listed tax certificate and hereby surrender the same to the Tax Collector and make tax deed application thereon:

Account Number	Certificate No.	Date	Legal Description
03-1994-130	2017/1324	06-01-2017	LT 19 BLK 7 OAKFIELD ACRES PARCEL 7 PB 6 P 82 OR 917 P 64 OR 4308 P 632 OR 6107 P 1924

I agree to:

- pay any current taxes, if due and
- redeem all outstanding tax certificates plus interest not in my possession, and
- pay all delinquent and omitted taxes, plus interest covering the property.
- pay all Tax Collector's fees, property information report costs, Clerk of the Court costs, charges and fees, and Sheriff's costs, if applicable.

Attached is the tax sale certificate on which this application is based and all other certificates of the same legal description which are in my possession.

Electronic signature on file
AFFILIATED TAX CO LLC - 17 US BANK % AFFILIATED
TAX CO LL
PO BOX 645040
CINCINNATI, OH 45264-5040

04-17-2019
Application Date

Applicant's signature



Chris Jones
Escambia County Property Appraiser

Real Estate Search Tangible Property Search Sale List

[Back](#)

Navigate Mode
 Account
 Reference

[Printer Friendly Version](#)

<p>General Information</p> <p>Reference: 281S304200019007</p> <p>Account: 031994130</p> <p>Owners: HEALY BETTY JO LIFE ESTATE & HEALY BETTY JO TRUSTEE FOR HEALY BETTY JO TRUST</p> <p>Mail: 6366 APPOMATTOX DR PENSACOLA, FL 32503</p> <p>Situs: 6366 APPOMATTOX DR 32503</p> <p>Use Code: SINGLE FAMILY RESID </p> <p>Taxing Authority: COUNTY MSTU</p> <p>Tax Inquiry: Open Tax Inquiry Window Tax Inquiry link courtesy of Scott Lunsford Escambia County Tax Collector</p>	<p>Assessments</p> <table border="1"> <thead> <tr> <th>Year</th> <th>Land</th> <th>Imprv</th> <th>Total</th> <th>Cap Val</th> </tr> </thead> <tbody> <tr> <td>2018</td> <td>\$22,800</td> <td>\$211,829</td> <td>\$234,629</td> <td>\$234,629</td> </tr> <tr> <td>2017</td> <td>\$22,800</td> <td>\$193,498</td> <td>\$216,298</td> <td>\$216,298</td> </tr> <tr> <td>2016</td> <td>\$22,800</td> <td>\$189,989</td> <td>\$212,789</td> <td>\$212,789</td> </tr> </tbody> </table> <p style="text-align: center;">Disclaimer</p> <hr/> <p style="text-align: center;">Tax Estimator</p> <p style="text-align: center;">> File for New Homestead Exemption Online</p>	Year	Land	Imprv	Total	Cap Val	2018	\$22,800	\$211,829	\$234,629	\$234,629	2017	\$22,800	\$193,498	\$216,298	\$216,298	2016	\$22,800	\$189,989	\$212,789	\$212,789
Year	Land	Imprv	Total	Cap Val																	
2018	\$22,800	\$211,829	\$234,629	\$234,629																	
2017	\$22,800	\$193,498	\$216,298	\$216,298																	
2016	\$22,800	\$189,989	\$212,789	\$212,789																	

<p>Sales Data</p> <table border="1"> <thead> <tr> <th>Sale Date</th> <th>Book</th> <th>Page</th> <th>Value</th> <th>Type</th> <th>Official Records (New Window)</th> </tr> </thead> <tbody> <tr> <td>03/2007</td> <td>6107</td> <td>1924</td> <td>\$100</td> <td>WD</td> <td>View Instr</td> </tr> <tr> <td>09/1998</td> <td>4308</td> <td>632</td> <td>\$15,200</td> <td>WD</td> <td>View Instr</td> </tr> <tr> <td>01/1975</td> <td>917</td> <td>64</td> <td>\$85,000</td> <td>WD</td> <td>View Instr</td> </tr> <tr> <td>01/1969</td> <td>432</td> <td>68</td> <td>\$4,800</td> <td>WD</td> <td>View Instr</td> </tr> </tbody> </table> <p>Official Records Inquiry courtesy of Pam Childers Escambia County Clerk of the Circuit Court and Comptroller</p>	Sale Date	Book	Page	Value	Type	Official Records (New Window)	03/2007	6107	1924	\$100	WD	View Instr	09/1998	4308	632	\$15,200	WD	View Instr	01/1975	917	64	\$85,000	WD	View Instr	01/1969	432	68	\$4,800	WD	View Instr	<p>2018 Certified Roll Exemptions</p> <p>None</p> <hr/> <p>Legal Description</p> <p>LT 19 BLK 7 OAKFIELD ACRES PARCEL 7 PB 6 P 82 OR 917 P 64 OR 4308 P 632 OR 6107 P 1924</p> <hr/> <p>Extra Features</p> <p>None</p>
Sale Date	Book	Page	Value	Type	Official Records (New Window)																										
03/2007	6107	1924	\$100	WD	View Instr																										
09/1998	4308	632	\$15,200	WD	View Instr																										
01/1975	917	64	\$85,000	WD	View Instr																										
01/1969	432	68	\$4,800	WD	View Instr																										

<p>Parcel Information</p> <p>Section Map Id: 28-1S-30</p> <p>Approx. Acreage: 1.2571</p> <p>Zoned: MDR</p> <p>Evacuation & Flood Information Open Report</p>	<p>Launch Interactive Map</p>
<p> View Florida Department of Environmental Protection(DEP) Data</p>	

Buildings

Address: 6366 APPOMATTOX DR, Year Built: 1974, Effective Year: 1974

<p>Structural Elements</p> <p>DECOR/MILLWORK-AVERAGE</p> <p>DWELLING UNITS-1</p> <p>EXTERIOR WALL-SIDING-LAP.AAVG</p> <p>FLOOR COVER-VINYL ASBESTOS</p>
--

FOUNDATION-WOOD/SUB FLOOR
HEAT/AIR-CENTRAL H/AC
INTERIOR WALL-DRYWALL-PLASTER
INTERIOR WALL-PANEL-PLYWOOD
NO. PLUMBING FIXTURES-9
NO. STORIES-2
ROOF COVER-DIMEN/ARCH SHNG
ROOF FRAMING-GABLE
STORY HEIGHT-0
STRUCTURAL FRAME-WOOD FRAME

 Areas - 5652 Total SF

BASE AREA - 2370
GARAGE FIN - 528
OPEN PORCH FIN - 732
OPEN PORCH UNF - 126
UPPER STORY FIN - 1245
UTILITY FIN - 651

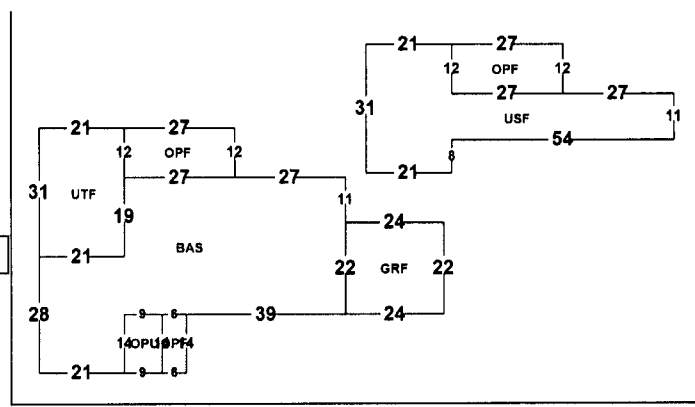

Images



2/12/19

The primary use of the assessment data is for the preparation of the current year tax roll. No responsibility or liability is assumed for inaccuracies or errors.

Last Updated:04/25/2019 (tc.26957)

NOTICE OF APPLICATION FOR TAX DEED

NOTICE IS HEREBY GIVEN, That **KEYS TAX FUNDING LLC- 17 US BANK** holder of **Tax Certificate No. 01324**, issued the **1st day of June, A.D., 2017** has filed same in my office and has made application for a tax deed to be issued thereon. Said certificate embraces the following described property in the County of Escambia, State of Florida, to wit:

LT 19 BLK 7 OAKFIELD ACRES PARCEL 7 PB 6 P 82 OR 917 P 64 OR 4308 P 632 OR 6107 P 1924

SECTION 28, TOWNSHIP 1 S, RANGE 30 W

TAX ACCOUNT NUMBER 031994130 (19-451)

The assessment of the said property under the said certificate issued was in the name of

BETTY JO HEALY LIFE ESTATE and BETTY JO HEALY TRUSTEE and BETTY JO HEALY TRUST

Unless said certificate shall be redeemed according to law, the property described therein will be sold to the highest bidder at public auction at 9:00 A.M. on the **first** Tuesday in the month of September, which is the **3rd day of September 2019**.

Dated this 29th day of April 2019.

In accordance with the AMERICANS WITH DISABILITIES ACT, if you are a person with a disability who needs special accommodation in order to participate in this proceeding you are entitled to the provision of certain assistance. Please contact Emily Hogg not later than seven days prior to the proceeding at Escambia County Government Complex, 221 Palafox Place Ste 110, Pensacola FL 32502. Telephone: 850-595-3793.



PAM CHILDERS
CLERK OF THE CIRCUIT COURT
ESCAMBIA COUNTY, FLORIDA

By:
Emily Hogg
Deputy Clerk

PAM CHILDERS
 CLERK OF THE CIRCUIT COURT
 ARCHIVES AND RECORDS
 CHILDSUPPORT
 CIRCUIT CIVIL
 CIRCUIT CRIMINAL
 COUNTY CIVIL
 COUNTY CRIMINAL
 DOMESTIC RELATIONS
 FAMILY LAW
 JURY ASSEMBLY
 JUVENILE
 MENTAL HEALTH
 MIS
 OPERATIONAL SERVICES
 PROBATE
 TRAFFIC



**COUNTY OF ESCAMBIA
 OFFICE OF THE
 CLERK OF THE CIRCUIT COURT**

**BRANCH OFFICES
 ARCHIVES AND RECORDS
 JUVENILE DIVISION
 CENTURY**

CLERK TO THE BOARD OF
 COUNTY COMMISSIONERS
 OFFICIAL RECORDS
 COUNTY TREASURY
 AUDITOR

**PAM CHILDERS, CLERK OF THE CIRCUIT COURT
 Tax Certificate Redeemed From Sale
 Account: 031994130 Certificate Number: 001324 of 2017**

Payor: MICHAEL HITCHCOCK 3993 WARD BASIN RD MILTON, FL 32583 Date 05/10/2019

Clerk's Check #	446524237	Clerk's Total	\$545.03
Tax Collector Check #	1	Tax Collector's Total	\$4,439.10
		Postage	\$60.00
		Researcher Copies	\$0.00
		Recording	\$10.00
		Prep Fee	\$7.00
		Total Received	\$5,061.13 \$4,362.69

**PAM CHILDERS
 Clerk of the Circuit Court**

Received By: *D. Cappage*
 Deputy Clerk

PAM CHILDERS
 CLERK OF THE CIRCUIT COURT
 ARCHIVES AND RECORDS
 CHILDSUPPORT
 CIRCUIT CIVIL
 CIRCUIT CRIMINAL
 COUNTY CIVIL
 COUNTY CRIMINAL
 DOMESTIC RELATIONS
 FAMILY LAW
 JURY ASSEMBLY
 JUVENILE
 MENTAL HEALTH
 MIS
 OPERATIONAL SERVICES
 PROBATE
 TRAFFIC



**COUNTY OF ESCAMBIA
 OFFICE OF THE
 CLERK OF THE CIRCUIT COURT**

**BRANCH OFFICES
 ARCHIVES AND RECORDS
 JUVENILE DIVISION
 CENTURY**

CLERK TO THE BOARD OF
 COUNTY COMMISSIONERS
 OFFICIAL RECORDS
 COUNTY TREASURY
 AUDITOR

**Case # 2017 TD 001324
 Redeemed Date 05/10/2019**

Name MICHAEL HITCHCOCK 3993 WARD BASIN RD MILTON, FL 32583

Clerk's Total = TAXDEED	\$545.03	} \$4,345.69
Due Tax Collector = TAXDEED	\$4,439.10	
Postage = TD2	\$60.00	
ResearcherCopies = TD6	\$0.00	
Release TDA Notice (Recording) = RECORD2	\$10.00	
Release TDA Notice (Prep Fee) = TD4	\$7.00	

• For Office Use Only

Date	Docket	Desc	Amount Owed	Amount Due	Payee Name
------	--------	------	-------------	------------	------------

FINANCIAL SUMMARY

No Information Available - See Dockets



PAM CHILDERS
CLERK OF THE CIRCUIT COURT
ESCAMBIA COUNTY, FLORIDA

Tax Deed - Redemption Calculator

Account: 031994130 Certificate Number: 001324 of 2017

Redemption	No	Application Date	04/01/2019	Interest Rate	18%
		Final Redemption Payment	ESTIMATED	Redemption Overpayment	ACTUAL
		Auction Date	09/03/2019	Redemption Date	05/10/2019
Months	5				1
Tax Collector	\$4,123.58				\$4,123.58
Tax Collector Interest	\$309.27				\$61.85
Tax Collector Fee	\$6.25				\$6.25
Total Tax Collector	\$4,439.10				\$4,191.68 T.C.
Record TDA Notice	\$17.00				\$17.00
Clerk Fee	\$130.00				\$130.00
Sheriff Fee	\$160.00				\$120.00
Legal Advertisement	\$200.00				\$200.00
App. Fee Interest	\$38.03				\$7.01
Total Clerk	\$545.03				\$474.01 C.H.
Release TDA Notice (Recording)	\$10.00				\$10.00
Release TDA Notice (Prep Fee)	\$7.00				\$7.00
Postage	\$60.00				\$0.00
Researcher Copies	\$40.00				\$0.00
Total Redemption Amount	\$5,101.13				\$4,682.69
		Repayment Overpayment Refund Amount			\$418.44
Book/Page					

Notes

RELEASE OF NOTICE OF APPLICATION FOR TAX DEED

Pursuant to § 197.502(5)(c), Florida Statutes, the Escambia County Clerk of Court fully releases the Notice of Tax Deed Application recorded at Official Records Book 8086, Page 580, of Escambia County, for the tax certificate, tax deed, and property described below:

Tax Certificate No. Certificate No. 00185, issued the 1st day of June, A.D., 2017

TAX ACCOUNT NUMBER: **012030000 (19-511)**

DESCRIPTION OF PROPERTY:

**LT 23 BLK 7 SCENIC HEIGHTS UNIT NO 3 PB 5 P 19 SEC 11/12/13 T 1S R 29 W OR 402 P 29 OR
6107 P 1926**

SECTION 11, TOWNSHIP 1 S, RANGE 29 W

NAME IN WHICH ASSESSED: **BETTY JO HEALY LIFE EST and BETTY JO HEALY TRUSTEE and
BETTY JO HEALY TRUST**

Dated this 10th day of May 2019.



PAM CHILDERS
CLERK OF THE CIRCUIT COURT
ESCAMBIA COUNTY, FLORIDA

By:
Emily Hogg
Deputy Clerk

Southern Guaranty Title Company

4400 Bayou Boulevard, Suite 13B
Pensacola, Florida 32503
Telephone: 850-478-8121
Facsimile: 850-476-1437

19-451

Redeemed

PROPERTY INFORMATION REPORT

File No.: 15205

June 4, 2019

Escambia County Tax Collector
P.O. Box 1312
Pensacola, Florida 32591

Pursuant to your request, the Company has caused a search to be made of the Public Records of Escambia County, Florida, solely as revealed by records maintained from 06-04-1999, through 06-04-2019, and said search reveals the following:

1. THE GRANTEE(S) OF THE LAST DEED(S) OF RECORD IS:

Betty Jo Healy, life estate, and as Trustee of the Betty Jo Healy Trust dated 03/13/2007

2. The land covered by this Report is:

LEGAL DESCRIPTION IS ATTACHED HERETO AND MADE A PART HEREOF

3. The following unsatisfied mortgages, liens and judgments affecting the land covered by this Report appear of record:

SEE CONTINUATION PAGE ATTACHED HERETO AND MADE A PART HEREOF

4. Taxes:

SEE CONTINUATION PAGE ATTACHED HERETO AND MADE A PART HEREOF

This report is not title insurance. Pursuant to s. 627.7843, Florida Statutes, the maximum liability of the issuer of this property information report for errors or omissions in this property information report is limited to the amount paid for this property information report, and is further limited to the person(s) expressly identified by name in the property information report as the recipients(s) of the property information report.

THIS REPORT SHALL NOT BE USED FOR THE ISSUANCE OF TITLE INSURANCE.

Southern Guaranty Title Company

By: 

June 4, 2019

**PROPERTY INFORMATION REPORT
LEGAL DESCRIPTION**

File No.: 15205

June 4, 2019

Lot 19, Block 7, Oakfield Acres, Parcel #7, as per plat thereof, recorded in Plat Book 6, Page 82, of the Public Records of Escambia County, Florida

**PROPERTY INFORMATION REPORT
CONTINUATION PAGE**

File No.: 15205

June 4, 2019

UNSATISFIED MORTGAGES, LIENS AND JUDGMENTS AFFECTING THE LAND COVERED BY THIS REPORT THAT APPEAR OF RECORD:

1. All Taxes Paid. The assessed value is \$234,629.00. Tax ID 03-1994-130.

PLEASE NOTE THE FOLLOWING:

- A. Subject to current year taxes.
- B. Taxes and assessments due now or in subsequent years.
- C. Subject to Easements, Restrictions and Covenants of record.
- D. Encroachments, overlaps, boundary line disputes, and any other matters which would be disclosed by an accurate survey and inspection of the premises.
- E. Oil, gas and mineral or any other subsurface rights of any kind or nature.

SOUTHERN GUARANTY TITLE COMPANY

4400 BAYOU BLVD., SUITE 13-B, CORDOVA SQUARE

PENSACOLA, FLORIDA 32503

TEL. (850) 478-8121 FAX (850) 476-1437

Email: rcsgt@aol.com

Scott Lunsford
Escambia County Tax Collector
P.O. Box 1312
Pensacola, FL 32591

CERTIFICATION: TITLE SEARCH FOR TDA

TAX DEED SALE DATE: 9-3-2019

TAX ACCOUNT NO.: 03-1994-130

CERTIFICATE NO.: 2017-1324

In compliance with Section 197.256, Florida Statutes, the following is a list of names and addresses of those persons, firms and/or agencies having legal interest in or claim against the above described property. The above referenced tax sale certificate is being submitted as proper notification of tax deed sale.

YES NO

Notify City of Pensacola, P.O. Box 12910, 32521

Notify Escambia County, 190 Governmental Center, 32502

Homestead for tax year.

Betty Jo Healy, Individually, and
as Trustee of the Betty Jo Healy
Trust dated 3-13-2007
6366 Appomattox Dr.
Pensacola, FL 32503

Certified and delivered to Escambia County Tax Collector,
this 4th day of June, 2019.

SOUTHERN GUARANTY TITLE COMPANY

by: Richard S. Combs, President

NOTE: The above listed addresses are based upon current information available, but said addresses are not guaranteed to be true or correct.

19.20
RETURN TO: Betty Jo Healy
6366 Appomattox Drive
Pensacola, FL 32503

Prepared by: Kathleen K. DeMaria
Smith, Sauer & DeMaria
P.O. Box 12446
Pensacola, FL 32591-2446

This deed is being prepared without the examination of title,
with legal description being provided to preparer by grantor.

W A R R A N T Y D E E D

THIS INDENTURE, Made this 13th day of March, 2007, between Betty Jo Healy, an unmarried woman, of the County of Escambia, State of Florida, hereinafter referred to as "grantor" and Betty Jo Healy for her life, without any liability for waste, and with full power and authority in said life tenant to sell, convey, mortgage, lease or otherwise manage and dispose of the property described herein, in fee simple, with or without consideration, without joinder of the remaindermen, and with full power and authority to retain any and all proceeds generated thereby, and upon the death of the last life tenant, the remainder, if any, Betty Jo Healy as Trustee of the Betty Jo Healy Revocable Trust Agreement dated March 13, 2007, by and between Betty Jo Healy as Grantor and Betty Jo Healy as Trustee, whose post office address is 6366 Appomattox Drive, Pensacola, Florida 32503, hereinafter called "grantee".

WITNESSETH, That said grantor, for and in consideration of the sum of TEN AND NO/100 DOLLARS (\$10.00), and other good and valuable considerations to said grantor in hand paid by said grantee, the receipt whereof is hereby acknowledged, has granted, bargained and sold to the said grantee, Betty Jo Healy for her life, and Betty Jo Healy as Trustee of the Betty Jo Healy Revocable Trust Agreement dated March 13, 2007, by and between Betty Jo Healy as Grantor and Betty Jo Healy as Trustee all of her interest in the following described land, situate, lying and being in Escambia County, Florida, to wit:

Lot 19, Block 7, Oakfield Acres, Parcel #7, A portion of Lot 4, Section 28, Township 1 South, Range 30 West, Escambia County, Florida, said Plat recorded in Plat Book 6, Page 82 of the Public Records of Escambia County, Florida. Because of an uncertainty as to the Eastern Boundary Line of the lot as shown on the recorded plat, it is understood that the eastern boundary line of the parcel of land being conveyed in as follows, to wit:

Commencing at the Southeast corner of Block 7, Oakfield Acres, Parcel #7, Escambia County, Florida as recorded in Plat Book 6, Page 82 of the Public Records of Escambia County, Florida, thence run North 11°10' East for 319.65 feet; thence North 25°31'30" East for 204.81 feet to the Southeast corner of Lot 19, Oakfield Acres, Parcel #6 and P.V. of a curve to the left

having a radius of 478.34 feet to the point of beginning of said common boundary line: thence along said curve for an arc distance of 225.38 feet at the Point "A", said Point "A" being the same Point "A" as shown on both of said recorded plats.

THIS IS THE HOMESTEAD OF THE GRANTOR.

Subject to taxes for the current year, zoning ordinances and restrictions, limitations and easements of record.

The above described property bearing Property Appraiser Parcel Identification No. 28-1S-30-4200-019-007.

And said grantor does hereby fully warrant the title to said land, and will defend the same against the lawful claims of all persons whomsoever. Grantor of the trust has conferred on the trustee the power and authority to protect, conserve, sell, lease, encumber, or otherwise manage and dispose of the real property described in this instrument.

*"Grantor" and "Grantee" are used for singular or plural, as context requires.

IN WITNESS WHEREOF, Grantor has hereunto set grantor's hand and seal the day and year first above written.

Signed, sealed and delivered in our presence:

Jennifer L. Pope
Jennifer L. Pope

Betty Jo Healy
Betty Jo Healy

Printed Name of Witness

Printed Name of Witness

STATE OF FLORIDA
COUNTY OF ESCAMBIA

The foregoing instrument was acknowledged before me this 13th day of March, 2007, by Betty Jo Healy,

- () to me personally known
- () Identified by Driver's License
- () Identified by _____

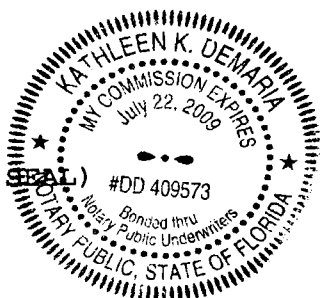

(NOTARY SEAL)

Kathleen K. DeMaria
Notary Public
Kathleen K. DeMaria
Printed Name
My Commission Expires: