

# Tax Collector's Certification

CTY-513

**Tax Deed Application Number**  
1900259

**Date of Tax Deed Application**  
Apr 19, 2019

This is to certify that **CAZENOVIA CREEK FUNDING II LLC**, holder of **Tax Sale Certificate Number 2017 / 211**, Issued the 1st Day of June, 2017 and which encumbers the following described property in the county of Escambia County , State of Florida, to wit: **01-2322-280**

**Cert Holder:**  
**CAZENOVIA CREEK FUNDING II LLC**  
**PO BOX 54132**  
**NEW ORLEANS, LA 70154**

**Property Owner:**  
**GUIDO EDUARDO C TRUST AGREEMENT 9-14-2007**  
**5197 E LAKE RD**  
**MILTON, FL 32583**  
**LT 10 BLK B KENSINGTON 5TH ADDN PB 10 P 59 OR 6103 P 1761**

has surrendered same in my office and made written application for tax deed in accordance with Florida Statutes. I certify that the following tax certificates, interest, ownership and encumbrance report fee, and Tax Collector's fees have been paid, or if the certificate is held by the County, all appropriate fees have been deposited.

Certificates owned by applicant and filed in connection with this application:

Certificate Year/Number	Account Number	Sale Date	Face Amount of Certificate	Interest	Total
2017/211	01-2322-280	06/01/2017	976.19	48.81	1,025.00
2018/167	01-2322-280	06/01/2018	2,777.77	138.89	2,916.66

Certificates redeemed by applicant or included (County) in connection with this tax deed application:

Certificate Year/Number	Account Number	Sale Date	Face Amount of Certificate	Tax Collector's Fee	Interest	Total
/						

**Amounts Certified by Tax Collector (Lines 1-7):**

- Total of all Certificates in Applicant's Possession and Cost of the Certificates Redeemed by Applicant
- Total of Delinquent Taxes Paid by Tax Deed Applicant
- Total of Current Taxes Paid by Tax Deed Applicant
- Property Information Report Fee
- Tax Deed Application Fee
- Total Interest Accrued by Tax Collector Pursuant to Section 197.542, F.S.
- Total (Lines 1 - 6)

**Total Amount Paid**

3,941.66
0.00
2,722.44
200.00
175.00
7,039.10

**Amounts Certified by Clerk of Court (Lines 8-15):**

- Clerk of Court Statutory Fee for Processing Tax Deed
- Clerk of Court Certified Mail Charge
- Clerk of Court Advertising Charge
- Clerk of Court Recording Fee for Certificate of Notice
- Sheriff's Fee
- Interest Computed by Clerk of Court Pursuant to Section 197.542, F.S.
- Total (Lines 8 - 13)
- One-half Assessed Value of Homestead Property, if Applicable per F.S.
- Other Outstanding Certificates and Delinquent Taxes Not Included in this Application,
- Statutory (Opening) Bid; Total of Lines 7, 14, 15 (if applicable) and 16 (if
- Redemption Fee
- Total Amount to Redeem

**Total Amount Paid**

12.50

Done this the 26th day of April, 2019 Scott Lunsford, Tax Collector of Escambia County

Date of Sale: November 4, 2019

By *Candice Lewis*

\*This certification must be surrendered to the Clerk of the Circuit Court no later than ten (10) days after this date.  
01-2322-280 2017

# APPLICATION FOR TAX DEED

Section 197.502, Florida Statutes

512  
R. 12/16

Application Number: 1900259

To: Tax Collector of ESCAMBIA COUNTY, Florida

I,  
CAZENOVIA CREEK FUNDING II LLC  
PO BOX 54132  
NEW ORLEANS, LA 70154,

hold the listed tax certificate and hereby surrender the same to the Tax Collector and make tax deed application thereon:

Account Number	Certificate No.	Date	Legal Description
01-2322-280	2017/211	06-01-2017	LT 10 BLK B KENSINGTON 5TH ADDN PB 10 P 59 OR 6103 P 1761

I agree to:

- pay any current taxes, if due and
- redeem all outstanding tax certificates plus interest not in my possession, and
- pay all delinquent and omitted taxes, plus interest covering the property.
- pay all Tax Collector's fees, property information report costs, Clerk of the Court costs, charges and fees, and Sheriff's costs, if applicable.

Attached is the tax sale certificate on which this application is based and all other certificates of the same legal description which are in my possession.

Electronic signature on file  
CAZENOVIA CREEK FUNDING II LLC  
PO BOX 54132  
NEW ORLEANS, LA 70154

04-19-2019  
Application Date

\_\_\_\_\_  
Applicant's signature



# Chris Jones Escambia County Property Appraiser

Real Estate Search | Tangible Property Search | Sale List

[Back](#)

◀ Navigate Mode  Account  Reference ▶

[Printer Friendly Version](#)

**General Information**  
**Reference:** 131S291200100002  
**Account:** 012322280  
**Owners:** GUIDO EDUARDO C TRUST AGREEMENT  
 9-14-2007  
**Mail:** 5197 E LAKE RD  
 MILTON, FL 32583  
**Situs:** 5510 TRAFALGAR DR 32504  
**Use Code:** SINGLE FAMILY RESID   
**Taxing Authority:** PENSACOLA CITY LIMITS  
**Tax Inquiry:** [Open Tax Inquiry Window](#)  
 Tax Inquiry link courtesy of Scott Lunsford  
 Escambia County Tax Collector

**Assessments**

Year	Land	Imprv	Total	Cap Val
2018	\$28,500	\$118,689	\$147,189	\$147,189
2017	\$28,500	\$108,418	\$136,918	\$136,918
2016	\$28,500	\$106,341	\$134,841	\$117,266

[Disclaimer](#)

**Tax Estimator**

> [File for New Homestead Exemption Online](#)

**Sales Data**

Sale Date	Book	Page	Value	Type	Official Records (New Window)
11/03/2017	7806	1277	\$100	CJ	<a href="#">View Instr</a>
10/16/2017	7793	1196	\$100	CJ	<a href="#">View Instr</a>
03/2007	6103	1761	\$210,000	WD	<a href="#">View Instr</a>
05/1993	3378	600	\$95,000	WD	<a href="#">View Instr</a>
10/1985	2132	687	\$16,500	WD	<a href="#">View Instr</a>
11/1982	1700	238	\$155,200	WD	<a href="#">View Instr</a>

Official Records Inquiry courtesy of Pam Childers  
 Escambia County Clerk of the Circuit Court and  
 Comptroller

**2018 Certified Roll Exemptions**  
 None

**Legal Description**  
 LT 10 BLK B KENSINGTON 5TH ADDN PB 10 P 59 OR 7793  
 P 1196 OR 7806 P 1277

**Extra Features**  
 None

**Parcel Information**

[Launch Interactive Map](#)

**Section Map Id:**  
 11-1S-29-2

**Approx. Acreage:**  
 0.2008

**Zoned:**   
 R-1AAA

**Evacuation & Flood Information**  
[Open Report](#)

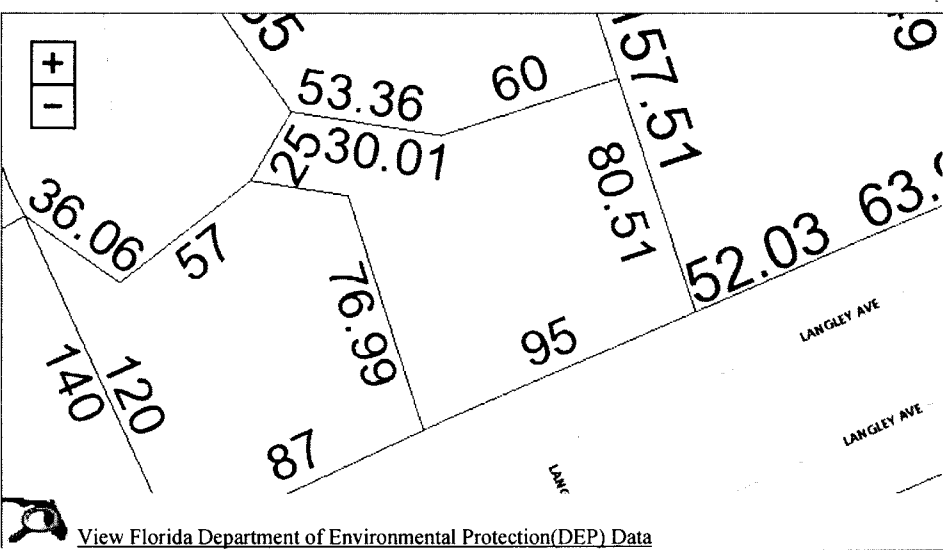

[View Florida Department of Environmental Protection\(DEP\) Data](#)

**Buildings**

Address: 5510 TRAFALGAR DR, Year Built: 1986, Effective Year: 1986

<b>Structural Elements</b> <b>DECOR/MILLWORK-ABOVE AVERAGE</b> <b>DWELLING UNITS-1</b>
--

**EXTERIOR WALL-VINYL SIDING**  
**FLOOR COVER-CARPET**  
**FOUNDATION-SLAB ON GRADE**  
**HEAT/AIR-CENTRAL H/AC**  
**INTERIOR WALL-DRYWALL-PLASTER**  
**NO. PLUMBING FIXTURES-8**  
**NO. STORIES-2**  
**ROOF COVER-COMPOSITION SHG**  
**ROOF FRAMING-IRR. ROOF DESGN**  
**STORY HEIGHT-0**  
**STRUCTURAL FRAME-WOOD FRAME**

 Areas - 2980 Total SF  
**BASE AREA - 1399**  
**GARAGE FIN - 462**  
**OPEN PORCH FIN - 78**  
**SCRN PORCH FIN - 315**  
**UPPER STORY FIN - 726**

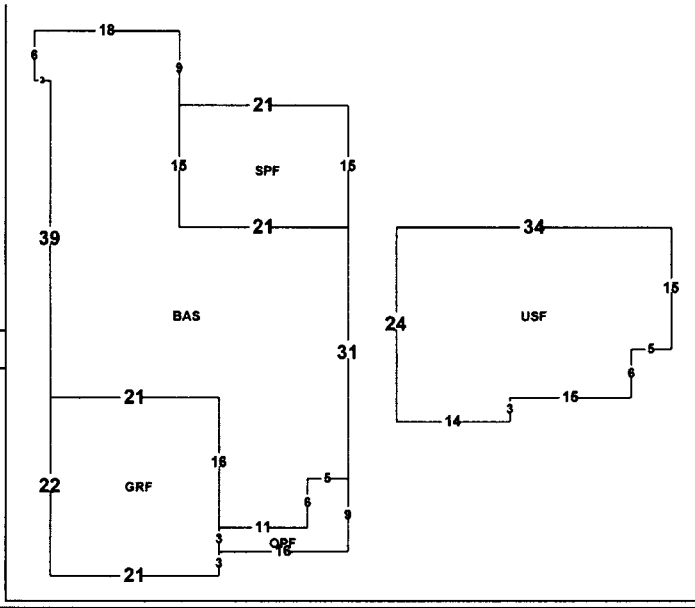

Images

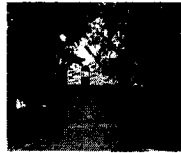

2/18/02

The primary use of the assessment data is for the preparation of the current year tax roll. No responsibility or liability is assumed for inaccuracies or errors.

## NOTICE OF APPLICATION FOR TAX DEED

NOTICE IS HEREBY GIVEN, That **CAZENOVIA CREEK FUNDING II LLC** holder of **Tax Certificate No. 00211**, issued the **1st day of June, A.D., 2017** has filed same in my office and has made application for a tax deed to be issued thereon. Said certificate embraces the following described property in the County of Escambia, State of Florida, to wit:

**LT 10 BLK B KENSINGTON 5TH ADDN PB 10 P 59 OR 6103 P 1761**

**SECTION 13, TOWNSHIP 1 S, RANGE 29 W**

**TAX ACCOUNT NUMBER 012322280 (19-512)**

The assessment of the said property under the said certificate issued was in the name of

**EDUARDO C GUIDO TRUST AGREEMENT 9-14-2007**

Unless said certificate shall be redeemed according to law, the property described therein will be sold to the highest bidder at public auction at 9:00 A.M. on the **first Monday** in the month of **November**, which is the **4th day of November 2019**.

Dated this 9th day of May 2019.

In accordance with the AMERICANS WITH DISABILITIES ACT, if you are a person with a disability who needs special accommodation in order to participate in this proceeding you are entitled to the provision of certain assistance. Please contact Emily Hogg not later than seven days prior to the proceeding at Escambia County Government Complex, 221 Palafox Place Ste 110, Pensacola FL 32502. Telephone: 850-595-3793.



PAM CHILDERS  
CLERK OF THE CIRCUIT COURT  
ESCAMBIA COUNTY, FLORIDA

By:  
Emily Hogg  
Deputy Clerk

**PAM CHILDERS**  
 CLERK OF THE CIRCUIT COURT  
 ARCHIVES AND RECORDS  
 CHILDSUPPORT  
 CIRCUIT CIVIL  
 CIRCUIT CRIMINAL  
 COUNTY CIVIL  
 COUNTY CRIMINAL  
 DOMESTIC RELATIONS  
 FAMILY LAW  
 JURY ASSEMBLY  
 JUVENILE  
 MENTAL HEALTH  
 MIS  
 OPERATIONAL SERVICES  
 PROBATE  
 TRAFFIC



**BRANCH OFFICES**  
**ARCHIVES AND RECORDS**  
**JUVENILE DIVISION**  
**CENTURY**

CLERK TO THE BOARD OF  
 COUNTY COMMISSIONERS  
 OFFICIAL RECORDS  
 COUNTY TREASURY  
 AUDITOR

**COUNTY OF ESCAMBIA**  
**OFFICE OF THE**  
**CLERK OF THE CIRCUIT COURT**

**PAM CHILDERS, CLERK OF THE CIRCUIT COURT**  
**Tax Certificate Redeemed From Sale**  
**Account: 012322280 Certificate Number: 000211 of 2017**

**Payor: MELISSA A TREMMEL 5197 E LAKE RD MILTON, FL 32583 Date 08/19/2019**

Clerk's Check #	5505256601	Clerk's Total	\$516.04
Tax Collector Check #	1	Tax Collector's Total	\$7,190.71
		Postage	\$16.80
		Researcher Copies	\$1.00
		Recording	\$10.00
		Prep Fee	\$7.00
		Total Received	\$8,341.55

*# 8323.55*

**PAM CHILDERS**  
 Clerk of the Circuit Court

Received By:  
 Deputy Clerk

**PAM CHILDERS**  
 CLERK OF THE CIRCUIT COURT  
 ARCHIVES AND RECORDS  
 CHILDSUPPORT  
 CIRCUIT CIVIL  
 CIRCUIT CRIMINAL  
 COUNTY CIVIL  
 COUNTY CRIMINAL  
 DOMESTIC RELATIONS  
 FAMILY LAW  
 JURY ASSEMBLY  
 JUVENILE  
 MENTAL HEALTH  
 MIS  
 OPERATIONAL SERVICES  
 PROBATE  
 TRAFFIC



**BRANCH OFFICES**  
**ARCHIVES AND RECORDS**  
**JUVENILE DIVISION**  
**CENTURY**

CLERK TO THE BOARD OF  
 COUNTY COMMISSIONERS  
 OFFICIAL RECORDS  
 COUNTY TREASURY  
 AUDITOR

**COUNTY OF ESCAMBIA**  
**OFFICE OF THE**  
**CLERK OF THE CIRCUIT COURT**

**Case # 2017 TD 000211**

**Redeemed Date 08/19/2019**

**Name MELISSA A TREMMEL 5197 E LAKE RD MILTON, FL 32583**

Clerk's Total = TAXDEED	\$516.04	<del>\$</del> 8323.55
Due Tax Collector = TAXDEED	\$7,790.71	
Postage = TD2	\$16.80	
ResearcherCopies = TD6	\$1.00	
Release TDA Notice (Recording) = RECORD2	\$10.00	
Release TDA Notice (Prep Fee) = TD4	\$7.00	

• For Office Use Only

Date	Docket	Desc	Amount Owed	Amount Due	Payee Name
------	--------	------	-------------	------------	------------

**FINANCIAL SUMMARY**

No Information Available - See Dockets

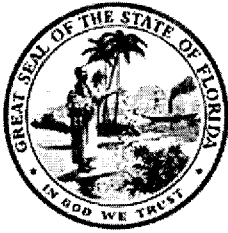

**PAM CHILDERS**  
**CLERK OF THE CIRCUIT COURT**  
**ESCAMBIA COUNTY, FLORIDA**

**Tax Deed - Redemption Calculator**

Account: 012322280 Certificate Number: 000211 of 2017

Redemption  No  Application Date  Interest Rate

	Final Redemption Payment ESTIMATED	Redemption Overpayment ACTUAL
	Auction Date <input type="text" value="11/04/2019"/>	Redemption Date <input type="text" value="08/19/2019"/>
Months	7	4
Tax Collector	<input type="text" value="\$7,039.10"/>	<input type="text" value="\$7,039.10"/>
Tax Collector Interest	\$739.11	\$422.35
Tax Collector Fee	<input type="text" value="\$12.50"/>	<input type="text" value="\$12.50"/>
Total Tax Collector	\$7,790.71	<input type="text" value="\$7,473.95"/> TC
Record TDA Notice	<input type="text" value="\$17.00"/>	<input type="text" value="\$17.00"/>
Clerk Fee	<input type="text" value="\$130.00"/>	<input type="text" value="\$130.00"/>
Sheriff Fee	<input type="text" value="\$120.00"/>	<input type="text" value="\$120.00"/>
Legal Advertisement	<input type="text" value="\$200.00"/>	<input type="text" value="\$200.00"/>
App. Fee Interest	\$49.04	\$28.02
Total Clerk	\$516.04	<input type="text" value="\$495.02"/> CH
Release TDA Notice (Recording)	<input type="text" value="\$10.00"/>	<input type="text" value="\$10.00"/>
Release TDA Notice (Prep Fee)	<input type="text" value="\$7.00"/>	<input type="text" value="\$7.00"/>
Postage	<input type="text" value="\$16.80"/>	<input type="text" value="\$0.00"/>
Researcher Copies	<input type="text" value="\$1.00"/>	<input type="text" value="\$1.00"/>
Total Redemption Amount	\$8,341.55	\$7,986.97
	Repayment Overpayment Refund Amount	\$354.58 + 120 + 200 = <input type="text" value="\$ 674.58"/>
Book/Page	<input type="text" value="8093"/>	<input type="text" value="514"/>

*Redeemer*

Notes



## RELEASE OF NOTICE OF APPLICATION FOR TAX DEED

Pursuant to § 197.502(5)(c), Florida Statutes, the Escambia County Clerk of Court fully releases the Notice of Tax Deed Application recorded at Official Records Book 8093, Page 514, of Escambia County, for the tax certificate, tax deed, and property described below:

Tax Certificate No. Certificate No. 00211, issued the 1st day of June, A.D., 2017

TAX ACCOUNT NUMBER: 012322280 (19-512)

DESCRIPTION OF PROPERTY:

LT 10 BLK B KENSINGTON 5TH ADDN PB 10 P 59 OR 6103 P 1761

SECTION 13, TOWNSHIP 1 S, RANGE 29 W

NAME IN WHICH ASSESSED: EDUARDO C GUIDO TRUST AGREEMENT 9-14-2007

Dated this 19th day of August 2019.



PAM CHILDERS  
CLERK OF THE CIRCUIT COURT  
ESCAMBIA COUNTY, FLORIDA

By:  
Emily Hogg  
Deputy Clerk

19-512

**Southern Guaranty Title Company**

4400 Bayou Boulevard, Suite 13B

Pensacola, Florida 32503

Telephone: 850-478-8121

Facsimile: 850-476-1437

**PROPERTY INFORMATION REPORT**

File No.: 15273

August 7, 2019

Escambia County Tax Collector  
P.O. Box 1312  
Pensacola, Florida 32591

Pursuant to your request, the Company has caused a search to be made of the Public Records of Escambia County, Florida, solely as revealed by records maintained from 08-07-1999, through 08-07-2019, and said search reveals the following:

1. THE GRANTEE(S) OF THE LAST DEED(S) OF RECORD IS:

Edwardo C. Guido Trust Agreement dated 09/14/2007

2. The land covered by this Report is:

LEGAL DESCRIPTION IS ATTACHED HERETO AND MADE A PART HEREOF

3. The following unsatisfied mortgages, liens and judgments affecting the land covered by this Report appear of record:

SEE CONTINUATION PAGE ATTACHED HERETO AND MADE A PART HEREOF

4. Taxes:

SEE CONTINUATION PAGE ATTACHED HERETO AND MADE A PART HEREOF

This report is not title insurance. Pursuant to s. 627.7843, Florida Statutes, the maximum liability of the issuer of this property information report for errors or omissions in this property information report is limited to the amount paid for this property information report, and is further limited to the person(s) expressly identified by name in the property information report as the recipients(s) of the property information report.

THIS REPORT SHALL NOT BE USED FOR THE ISSUANCE OF TITLE INSURANCE.

Southern Guaranty Title Company

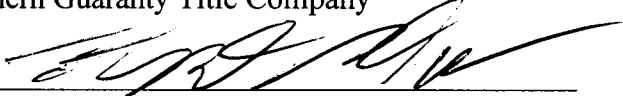
By: 

August 7, 2019

**PROPERTY INFORMATION REPORT  
LEGAL DESCRIPTION**

File No.: 15273

August 7, 2019

**Lot 10, Block B, 5th Addition to Kensington, as per plat thereof, recorded in Plat Book 10, Page 59, of the Public Records of Escambia County, Florida**

**PROPERTY INFORMATION REPORT  
CONTINUATION PAGE**

File No.: 15273

August 7, 2019

UNSATISFIED MORTGAGES, LIENS AND JUDGMENTS AFFECTING THE LAND COVERED BY THIS REPORT THAT APPEAR OF RECORD:

1. Taxes for the year 2016-2018 delinquent. The assessed value is \$147,189.00. Tax ID 01-2322-280.

PLEASE NOTE THE FOLLOWING:

- A. Subject to current year taxes.
- B. Taxes and assessments due now or in subsequent years.
- C. Subject to Easements, Restrictions and Covenants of record.
- D. Encroachments, overlaps, boundary line disputes, and any other matters which would be disclosed by an accurate survey and inspection of the premises.
- E. Oil, gas and mineral or any other subsurface rights of any kind or nature.

# SOUTHERN GUARANTY TITLE COMPANY

4400 BAYOU BLVD., SUITE 13-B, CORDOVA SQUARE

PENSACOLA, FLORIDA 32503

TEL. (850) 478-8121 FAX (850) 476-1437

Email: rcsqt@aol.com

Scott Lunsford  
Escambia County Tax Collector  
P.O. Box 1312  
Pensacola, FL 32591

CERTIFICATION: TITLE SEARCH FOR TDA

TAX DEED SALE DATE: 11-4-2019

TAX ACCOUNT NO.: 01-2322-280

CERTIFICATE NO.: 2017-211

In compliance with Section 197.256, Florida Statutes, the following is a list of names and addresses of those persons, firms and/or agencies having legal interest in or claim against the above described property. The above referenced tax sale certificate is being submitted as proper notification of tax deed sale.

YES NO

     Notify City of Pensacola, P.O. Box 12910, 32521

     Notify Escambia County, 190 Governmental Center, 32502

     Homestead for     tax year.

Eduardo C. Guido Trust  
Agreement dated 9-14-2007  
Attn: Melissa Tremmel, Trustee  
5197 E. Lake Rd.  
Milton, FL 32583  
and  
5510 Trafalgar Dr.  
Pensacola, FL 32504

Certified and delivered to Escambia County Tax Collector,  
this 8th day of August, 2019.

SOUTHERN GUARANTY TITLE COMPANY

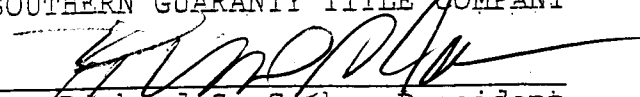
  
by: Richard S. Combs, President

NOTE: The above listed addresses are based upon current information available, but said addresses are not guaranteed to be true or correct.

THIS INSTRUMENT PREPARED BY AND RETURN TO:  
Linda Salter  
SURETY LAND TITLE OF FLORIDA, LLC  
2600 NORTH 12TH AVE.  
PENSACOLA, FL 32503  
Property Appraisers Parcel Identification (Folio) Numbers: 131S29-1200-100-002

# WARRANTY DEED

Space Above This Line For Recording Data

**THIS WARRANTY DEED**, made the 6th day of March, 2007 by Charlene E. Busbee, a single woman, whose post office address is 222 Bayou Boulevard, Pensacola, FL 32503 herein called the grantor, to E. C. Guido, a single man, whose post office address is 5510 Trafalgar Drive, Pensacola, Florida 32504, hereinafter called the Grantee:  
*(Wherever used herein the terms "grantor" and "grantee" include all the parties to this instrument and the heirs, legal representatives and assigns of individuals, and the successors and assigns of corporations)*

**WITNESSETH:** That the grantor, for and in consideration of the sum of TEN AND 00/100'S (\$10.00) Dollars and other valuable considerations, receipt whereof is hereby acknowledged, hereby grants, bargains, sells, aliens, remises, releases, conveys and confirms unto the grantee all that certain land situate in ESCAMBIA County, State of Florida, viz.:

**Lot 10, Block B, 5th Addition to Kensington, a subdivision of a portion of Section 13, Township 1 South, Range 29 West, Escambia County, Florida, according to the plat thereof, recorded in Plat Book 10, Page 59, of the Public Records of said County.**

Subject to easements, restrictions and reservations of record and taxes for the year 2007 and thereafter.

**TOGETHER**, with all the tenements, hereditaments and appurtenances thereto belonging or in anywise appertaining.

**TO HAVE AND TO HOLD**, the same in fee simple forever.

**AND**, the grantor hereby covenants with said grantee that the grantor is lawfully seized of said land in fee simple; that the grantor has good right and lawful authority to sell and convey said land, and hereby warrants the title to said land and will defend the same against the lawful claims of all persons whomsoever; and that said land is free of all encumbrances, except taxes accruing subsequent to December 31, 2006

**IN WITNESS WHEREOF**, the said grantor has signed and sealed these presents the day and year first above written.

Signed, sealed and delivered in the presence of:

Linda Salter  
Witness #1 Signature

Charlene E. Busbee  
Charlene E. Busbee

LINDA SALTER  
Witness #1 Printed Name

Miller McComb  
Witness #2 Signature

MILLER McCOMB  
Witness #2 Printed Name

STATE OF FLORIDA

COUNTY OF ESCAMBIA

The foregoing instrument was acknowledged before me this 6th day of March, 2007 by Charlene E. Busbee who is personally known to me or has produced a drivers license as identification.

SEAL

Linda S. Salter  
Notary Public

LINDA G. SALTER  
Notary Public-State of FL  
Comm. Exp. June 17, 2007

Printed Notary Name

My Commission Expires: June 17, 2007