

Tax Collector's Certification

Tax Deed Application Number
1800146

Date of Tax Deed Application
Apr 25, 2018

This is to certify that **MTAG AS CUSTODIAN FOR CAZ CREEK FLORIDA II, LLC**, holder of **Tax Sale Certificate Number 2016 / 6005**, Issued the 1st Day of June, 2016 and which encumbers the following described property in the county of Escambia County , State of Florida, to wit: **10-4333-854**

Cert Holder:
MTAG AS CUSTODIAN FOR CAZ CREEK FLORIDA II, LLC
PO BOX 54900
NEW ORLEANS, LA 70154

Property Owner:
BLUE MICHAEL S
4654 ISLES DR
PENSACOLA, FL 32507
LT 10 & N 33 FT OF LT 9 BLK B INNERARITY ISLES PB 16 P 88 OR 6412 P 982

has surrendered same in my office and made written application for tax deed in accordance with Florida Statutes. I certify that the following tax certificates, interest, ownership and encumbrance report fee, and Tax Collector's fees have been paid, or if the certificate is held by the County, all appropriate fees have been deposited.

Certificates owned by applicant and filed in connection with this application:

Certificate Year/Number	Account Number	Sale Date	Face Amount of Certificate	Interest	Total
2016/6005	10-4333-854	06/01/2016	2,636.00	131.80	2,767.80
2017/5963	10-4333-854	06/01/2017	2,747.74	137.39	2,885.13

Certificates redeemed by applicant or included (County) in connection with this tax deed application:

Certificate Year/Number	Account Number	Sale Date	Face Amount of Certificate	Tax Collector's Fee	Interest	Total
/						

Amounts Certified by Tax Collector (Lines 1-7):

Total Amount Paid

1. Total of all Certificates in Applicant's Possession and Cost of the Certificates Redeemed by Applicant	5,652.93
2. Total of Delinquent Taxes Paid by Tax Deed Applicant	0.00
3. Total of Current Taxes Paid by Tax Deed Applicant	2,695.22
4. Ownership and Encumbrance Report Fee	200.00
5. Tax Deed Application Fee	175.00
6. Total Interest Accrued by Tax Collector Pursuant to Section 197.542, F.S.	
7. Total (Lines 1 - 6)	8,723.15

Amounts Certified by Clerk of Court (Lines 8-15):

Total Amount Paid

8. Clerk of Court Statutory Fee for Processing Tax Deed	
9. Clerk of Court Certified Mail Charge	
10. Clerk of Court Advertising Charge	
11. Clerk of Court Recording Fee for Certificate of Notice	
12. Sheriff's Fee	
13. Interest Computed by Clerk of Court Pursuant to Section 197.542, F.S.	
14. Total (Lines 8 - 13)	
15. One-half Assessed Value of Homestead Property, if Applicable per F.S.	
16. Other Outstanding Certificates and Delinquent Taxes Not Included in this Application, If Applicable Per Florida Statutes	
17. Statutory (Opening) Bid; Total of Lines 7, 14, 15 (if applicable) and 16 (if applicable)	
18. Redemption Fee	12.50
19. Total Amount to Redeem	

Done this the 26th day of April, 2018 Scott Lunsford, Tax Collector of Escambia County

Date of Sale: August 6, 2018

By *Jennifer M. Cassidy*

*This certification must be surrendered to the Clerk of the Circuit Court no later than ten (10) days after this date.

10-4333-854 2016

APPLICATION FOR TAX DEED

Section 197.502, Florida Statutes

512
R. 12/16

Application Number: 1800146

To: Tax Collector of ESCAMBIA COUNTY, Florida

I,
MTAG AS CUSTODIAN FOR CAZ CREEK FLORIDA II, LLC
PO BOX 54900
NEW ORLEANS, LA 70154,

hold the listed tax certificate and hereby surrender the same to the Tax Collector and make tax deed application thereon:

Account Number	Certificate No.	Date	Legal Description
10-4333-854	2016/6005	06-01-2016	LT 10 & N 33 FT OF LT 9 BLK B INNERARITY ISLES PB 16 P 88 OR 6412 P 982

I agree to:

- pay any current taxes, if due and
- redeem all outstanding tax certificates plus interest not in my possession, and
- pay all delinquent and omitted taxes, plus interest covering the property.
- pay all Tax Collector's fees, ownership and encumbrance report costs, Clerk of the Court costs, charges and fees, and Sheriff's costs, if applicable.

Attached is the tax sale certificate on which this application is based and all other certificates of the same legal description which are in my possession.

Electronic signature on file
MTAG AS CUSTODIAN FOR CAZ CREEK FLORIDA II,
LLC
PO BOX 54900
NEW ORLEANS, LA 70154

04-25-2018
Application Date

Applicant's signature



Chris Jones Escambia County Property Appraiser

- Real Estate Search
- Tangible Property Search
- Sale List
- Amendment 1/Portability Calculations

[Back](#)

← Navigate Mode Account Reference →

Printer Friendly Version

General Information	
Reference:	153S321180100002
Account:	104333854
Owners:	BLUE MICHAEL S
Mail:	4654 ISLES DR PENSACOLA, FL 32507
Situs:	4654 ISLES DR 32507
Use Code:	SINGLE FAMILY RESID
Taxing Authority:	COUNTY MSTU
Schools (Elem/Int/High):	HELLEN CARO/BAILEY/ESCAMBIA
Tax Inquiry:	Open Tax Inquiry Window
Tax Inquiry link courtesy of Scott Lunsford Escambia County Tax Collector	

Assessments				
Year	Land	Imprv	Total	Cap Val
2017	\$24,225	\$149,672	\$173,897	\$173,897
2016	\$24,225	\$137,135	\$161,360	\$161,360
2015	\$24,225	\$129,684	\$153,909	\$153,909

[Disclaimer](#)

[Amendment 1/Portability Calculations](#)

➤ [File for New Homestead Exemption Online](#)

Sales Data					
Sale Date	Book	Page	Value	Type	Official Records (New Window)
12/30/2008	6412	982	\$100	CJ	View Instr
05/2002	4904	174	\$50,000	WD	View Instr

Official Records Inquiry courtesy of Pam Childers
Escambia County Clerk of the Circuit Court and Comptroller

2017 Certified Roll Exemptions
None

Legal Description
LT 10 & N 33 FT OF LT 9 BLK B INNERARITY ISLES PB 16 P 88 OR 6412 P 982

Extra Features
None

Parcel Information [Launch Interactive Map](#)

Section Map Id:
15-3S-32-1

Approx. Acreage:
0.1886

Zoned:
MDR

Evacuation & Flood Information
[Open Report](#)

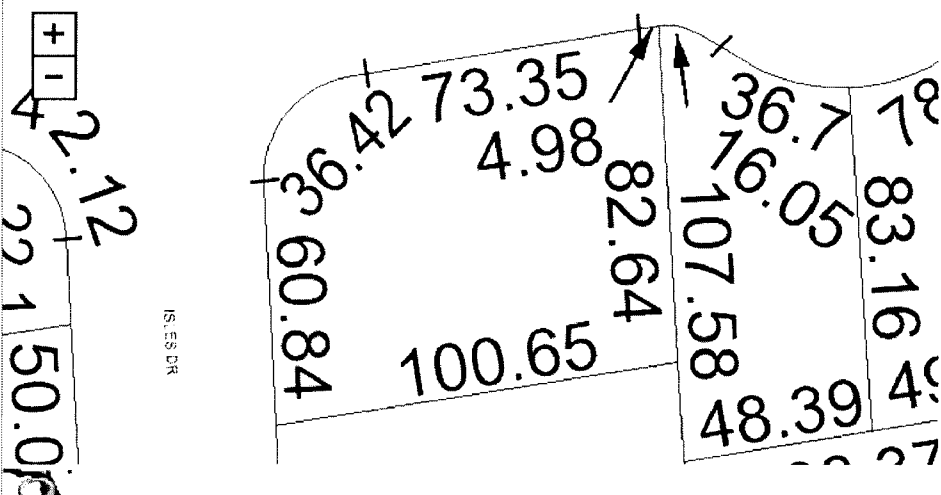

[View Florida Department of Environmental Protection\(DEP\) Data](#)

Buildings

Address: 4654 ISLES DR, Year Built: 2004, Effective Year: 2004	
Structural Elements	
DECOR/MILLWORK-AVERAGE	
DWELLING UNITS-1	
EXTERIOR WALL-BRICK-FACE/VENEER	
FLOOR COVER-CARPET	
FOUNDATION-SLAB ON GRADE	

HEAT/AIR-CENTRAL H/AC
INTERIOR WALL-DRYWALL-DECORAT
NO. PLUMBING FIXTURES-8
NO. STORIES-1
ROOF COVER-DIMEN/ARCH SHNG
ROOF FRAMING-HIP
STORY HEIGHT-0
STRUCTURAL FRAME-WOOD FRAME

 Areas - 3299 Total SF
BASE AREA - 2077
GARAGE FIN - 636
OPEN PORCH FIN - 208
PATIO - 288
UTILITY FIN - 90

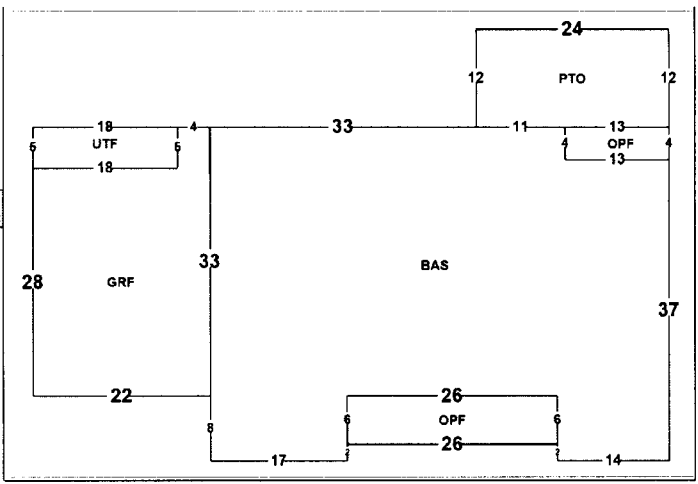

Images



8/25/15

The primary use of the assessment data is for the preparation of the current year tax roll. No responsibility or liability is assumed for inaccuracies or errors.

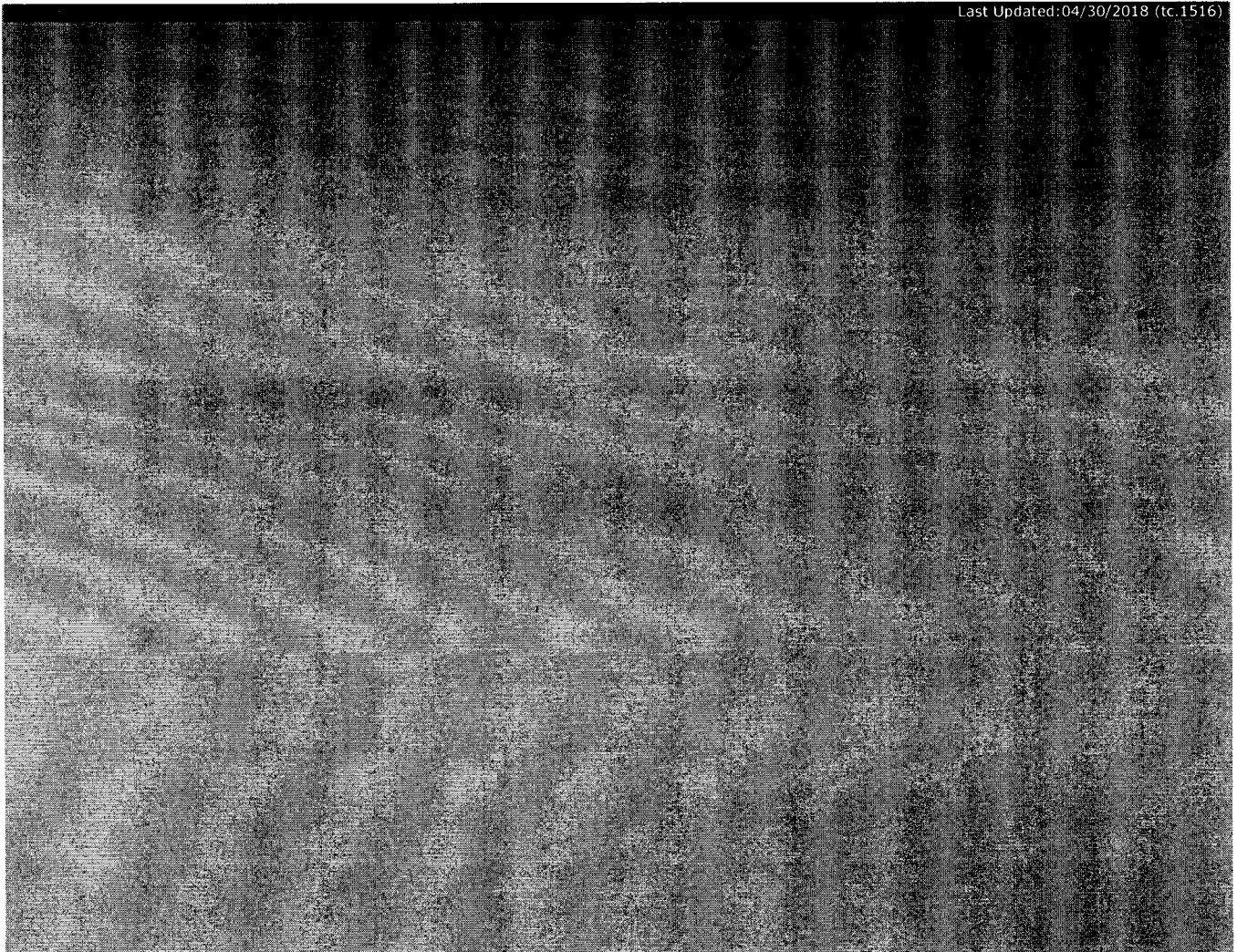

PAM CHILDERS
 CLERK OF THE CIRCUIT COURT
 ARCHIVES AND RECORDS
 CHILDSUPPORT
 CIRCUIT CIVIL
 CIRCUIT CRIMINAL
 COUNTY CIVIL
 COUNTY CRIMINAL
 DOMESTIC RELATIONS
 FAMILY LAW
 JURY ASSEMBLY
 JUVENILE
 MENTAL HEALTH
 MIS
 OPERATIONAL SERVICES
 PROBATE
 TRAFFIC



BRANCH OFFICES
ARCHIVES AND RECORDS
JUVENILE DIVISION
CENTURY

CLERK TO THE BOARD OF
 COUNTY COMMISSIONERS
 OFFICIAL RECORDS
 COUNTY TREASURY
 AUDITOR

COUNTY OF ESCAMBIA
OFFICE OF THE
CLERK OF THE CIRCUIT COURT

PAM CHILDERS, CLERK OF THE CIRCUIT COURT
Tax Certificate Redeemed From Sale
Account: 104333854 Certificate Number: 006005 of 2016

Payor: LEGAL COUNSEL PA IOTA TRUST ACCOUNT 1999 W COLONIAL DR ORLANDO FL
32804 Date 05/24/2018

Clerk's Check #	1	Clerk's Total	\$477.00
Tax Collector Check #	1	Tax Collector's Total	\$9,259.04
		Postage	\$60.00
		Researcher Copies	\$40.00
		Total Received	\$9,836.04

\$9003.25

PAM CHILDERS
 Clerk of the Circuit Court

Received By
 Deputy Clerk

Escambia County Government Complex • 221 Palafox Place Ste 110 • PENSACOLA, FLORIDA 32502
 (850) 595-3793 • FAX (850) 595-4827 • <http://www.clerk.co.escambia.fl.us>

PAM CHILDERS
 CLERK OF THE CIRCUIT COURT
 ARCHIVES AND RECORDS
 CHILDSUPPORT
 CIRCUIT CIVIL
 CIRCUIT CRIMINAL
 COUNTY CIVIL
 COUNTY CRIMINAL
 DOMESTIC RELATIONS
 FAMILY LAW
 JURY ASSEMBLY
 JUVENILE
 MENTAL HEALTH
 MIS
 OPERATIONAL SERVICES
 PROBATE
 TRAFFIC



BRANCH OFFICES
ARCHIVES AND RECORDS
JUVENILE DIVISION
CENTURY

CLERK TO THE BOARD OF
 COUNTY COMMISSIONERS
 OFFICIAL RECORDS
 COUNTY TREASURY
 AUDITOR

COUNTY OF ESCAMBIA
OFFICE OF THE
CLERK OF THE CIRCUIT COURT

Case # 2016 TD 006005
Redeemed Date 05/24/2018

Name LEGAL COUNSEL PA IOTA TRUST ACCOUNT 1999 W COLONIAL DR ORLANDO FL 32804

Clerk's Total = TAXDEED	\$477.00
Due Tax Collector = TAXDEED	\$9,259.04 \$ 9003.25
Postage = TD2	\$60.00
ResearcherCopies = TD6	\$40.00

• For Office Use Only

Date	Docket	Desc	Amount Owed	Amount Due	Payee Name
------	--------	------	-------------	------------	------------

FINANCIAL SUMMARY

No Information Available - See Dockets

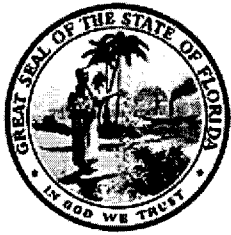

PAM CHILDERS
CLERK OF THE CIRCUIT COURT
ESCAMBIA COUNTY, FLORIDA

Tax Deed - Redemption Calculator

Account: 104333854 Certificate Number: 006005 of 2016

Redemption No Application Date Interest Rate

	Final Redemption Payment ESTIMATED	Redemption Overpayment ACTUAL
	Auction Date <input type="text" value="08/06/2018"/>	Redemption Date <input type="text" value="05/24/2018"/>
Months	4	1
Tax Collector	<input type="text" value="\$8,723.15"/>	<input type="text" value="\$8,723.15"/>
Tax Collector Interest	\$523.39	\$130.85
Tax Collector Fee	<input type="text" value="\$12.50"/>	<input type="text" value="\$12.50"/>
Total Tax Collector	\$9,259.04	<input type="text" value="\$8,866.50"/> TC
Clerk Fee	<input type="text" value="\$130.00"/>	<input type="text" value="\$130.00"/>
Sheriff Fee	<input type="text" value="\$120.00"/>	<input type="text" value="\$120.00"/>
Legal Advertisement	<input type="text" value="\$200.00"/>	<input type="text" value="\$200.00"/>
App. Fee Interest	\$27.00	\$6.75
Total Clerk	\$477.00	<input type="text" value="\$456.75"/> CH
Postage	<input type="text" value="\$60.00"/>	<input type="text" value="\$0.00"/>
Researcher Copies	<input type="text" value="\$40.00"/>	<input type="text" value="\$0.00"/>
Total Redemption Amount	\$9,836.04	\$9,323.25
	Repayment Overpayment Refund Amount	\$512.79

Notes



Pam Childers

Clerk of the Circuit Court and Comptroller, Escambia County

Clerk of Courts • County Comptroller • Clerk of the Board of County Commissioners • Recorder •

May 30, 2018

MTAG AS CUSTODIAN FOR CAZ CREEK FLORIDA II LLC
PO BOX 54900
NEW ORLEANS LA 70154

Dear Certificate Holder:

The records of this office show that an application for a tax deed had been made on the property represented by the numbered certificate listed below. The property redeemed prior to sale; therefore your application fees are now refundable.

TAX CERT	APP FEES	INTEREST	TOTAL
2016 TD 000588	\$450.00	\$6.75	\$456.75
2016 TD 007149	\$450.00	\$6.75	\$456.75
2016 TD 001370	\$450.00	\$6.75	\$456.75
2016 TD 004007	\$450.00	\$6.75	\$456.75
2016 TD 000021	\$450.00	\$6.75	\$456.75
2016 TD 003940	\$450.00	\$6.75	\$456.75
2016 TD 006005	\$450.00	\$6.75	\$456.75

TOTAL \$3,197.25

Very truly yours,

PAM CHILDERS
Clerk of Circuit Court

By:

Emily Hogg
Tax Deed Division

Southern Guaranty Title Company

4400 Bayou Boulevard, Suite 13B

Pensacola, Florida 32503

Telephone: 850-478-8121

Facsimile: 850-476-1437

18-308
Redeemed

PROPERTY INFORMATION REPORT

File No.: 14307

May 6, 2018

Escambia County Tax Collector
P.O. Box 1312
Pensacola, Florida 32591

Pursuant to your request, the Company has caused a search to be made of the Public Records of Escambia County, Florida, solely as revealed by records maintained from 05-02-1998, through 05-02-2018, and said search reveals the following:

1. THE GRANTEE(S) OF THE LAST DEED(S) OF RECORD IS:

Michael S. Blue

2. The land covered by this Report is:

LEGAL DESCRIPTION IS ATTACHED HERETO AND MADE A PART HEREOF

3. The following unsatisfied mortgages, liens and judgments affecting the land covered by this Report appear of record:

SEE CONTINUATION PAGE ATTACHED HERETO AND MADE A PART HEREOF

4. Taxes:

SEE CONTINUATION PAGE ATTACHED HERETO AND MADE A PART HEREOF

This report is not title insurance. Pursuant to s. 627.7843, Florida Statutes, the maximum liability of the issuer of this property information report for errors or omissions in this property information report is limited to the amount paid for this property information report, and is further limited to the person(s) expressly identified by name in the property information report as the recipients(s) of the property information report.

THIS REPORT SHALL NOT BE USED FOR THE ISSUANCE OF TITLE INSURANCE.

Southern Guaranty Title Company

By: 

May 6, 2018

**PROPERTY INFORMATION REPORT
LEGAL DESCRIPTION**

File No.: 14307

May 6, 2018

Lot 10 and North 33 feet of Lot 9, Block B, Innerarity Isles, Plat Book 16, Page 88, O.R. Book 6412, page 982, of the Public Records of Escambia County, Florida

**PROPERTY INFORMATION REPORT
CONTINUATION PAGE**

File No.: 14307

May 6, 2018

UNSATISFIED MORTGAGES, LIENS AND JUDGMENTS AFFECTING THE LAND COVERED BY THIS REPORT THAT APPEAR OF RECORD:

1. Subject to interest of Innerarity Isles Homeowners Association.
2. Taxes for the year 2015-2017 delinquent. The assessed value is \$173,897.00. Tax ID 10-4333-854.

PLEASE NOTE THE FOLLOWING:

- A. Subject to current year taxes.
- B. Taxes and assessments due now or in subsequent years.
- C. Subject to Easements, Restrictions and Covenants of record.
- D. Encroachments, overlaps, boundary line disputes, and any other matters which would be disclosed by an accurate survey and inspection of the premises.
- E. Oil, gas and mineral or any other subsurface rights of any kind or nature.

SOUTHERN GUARANTY TITLE COMPANY

4400 BAYOU BLVD., SUITE 13-B, CORDOVA SQUARE

PENSACOLA, FLORIDA 32503

TEL. (850) 478-8121 FAX (850) 476-1437

Email: rcsqt@aol.com

Scott Lunsford
Escambia County Tax Collector
P.O. Box 1312
Pensacola, FL 32591

CERTIFICATION: TITLE SEARCH FOR TDA

TAX DEED SALE DATE: 8-6-2018

TAX ACCOUNT NO.: 10-4333-854

CERTIFICATE NO.: 2016-6005

In compliance with Section 197.256, Florida Statutes, the following is a list of names and addresses of those persons, firms and/or agencies having legal interest in or claim against the above described property. The above referenced tax sale certificate is being submitted as proper notification of tax deed sale.

YES NO

 Notify City of Pensacola, P.O. Box 12910, 32521

 Notify Escambia County, 190 Governmental Center, 32502

 Homestead for tax year.

Michael S. Blue
4654 Isles Dr.
Pensacola, FL 32507

Innerarity Isles HOA
4642 Isles Dr.
Pensacola, FL 32507

Certified and delivered to Escambia County Tax Collector,
this 6th day of May, 2018.

SOUTHERN GUARANTY TITLE COMPANY

by: Richard S. Combs, President

NOTE: The above listed addresses are based upon current information available, but said addresses are not guaranteed to be true or correct.