

Tax Collector's Certification

CTY-513

Tax Deed Application Number
1800114

Date of Tax Deed Application
Apr 25, 2018

This is to certify that **MTAG AS CUSTODIAN FOR CAZ CREEK FLORIDA II, LLC**, holder of **Tax Sale Certificate Number 2016 / 1991**, Issued the 1st Day of June, 2016 and which encumbers the following described property in the county of Escambia County, State of Florida, to wit: **05-0432-000**

Cert Holder:
MTAG AS CUSTODIAN FOR CAZ CREEK FLORIDA II, LLC
PO BOX 54900
NEW ORLEANS, LA 70154

Property Owner:
NUNES JOSE
820 S HWY 97
CANTONMENT, FL 32533
LT 11 BLK 3 2ND ADDN HIGHLAND TERRACE PB 3 P 37/51 /59 OR 6029 P 59

has surrendered same in my office and made written application for tax deed in accordance with Florida Statutes. I certify that the following tax certificates, interest, ownership and encumbrance report fee, and Tax Collector's fees have been paid, or if the certificate is held by the County, all appropriate fees have been deposited.

Certificates owned by applicant and filed in connection with this application:

Certificate Year/Number	Account Number	Sale Date	Face Amount of Certificate	Interest	Total
2016/1991	05-0432-000	06/01/2016	1,202.66	60.13	1,262.79

Certificates redeemed by applicant or included (County) in connection with this tax deed application:

Certificate Year/Number	Account Number	Sale Date	Face Amount of Certificate	Tax Collector's Fee	Interest	Total
2017/1983	05-0432-000	06/01/2017	1,239.44	6.25	61.97	1,307.66

Amounts Certified by Tax Collector (Lines 1-7):

Total Amount Paid

1. Total of all Certificates in Applicant's Possession and Cost of the Certificates Redeemed by Applicant	2,570.45
2. Total of Delinquent Taxes Paid by Tax Deed Applicant	0.00
3. Total of Current Taxes Paid by Tax Deed Applicant	1,108.60
4. Ownership and Encumbrance Report Fee	200.00
5. Tax Deed Application Fee	175.00
6. Total Interest Accrued by Tax Collector Pursuant to Section 197.542, F.S.	
7. Total (Lines 1 - 6)	4,054.05

Amounts Certified by Clerk of Court (Lines 8-15):

Total Amount Paid

8. Clerk of Court Statutory Fee for Processing Tax Deed	
9. Clerk of Court Certified Mail Charge	
10. Clerk of Court Advertising Charge	
11. Clerk of Court Recording Fee for Certificate of Notice	
12. Sheriff's Fee	
13. Interest Computed by Clerk of Court Pursuant to Section 197.542, F.S.	
14. Total (Lines 8 - 13)	
15. One-half Assessed Value of Homestead Property, if Applicable per F.S.	
16. Other Outstanding Certificates and Delinquent Taxes Not Included in this Application, If Applicable Per Florida Statutes	
17. Statutory (Opening) Bid; Total of Lines 7, 14, 15 (if applicable) and 16 (if applicable)	
18. Redemption Fee	6.25
19. Total Amount to Redeem	

Done this the 26th day of April, 2018 Scott Lunsford, Tax Collector of Escambia County

Date of Sale: August 6, 2018

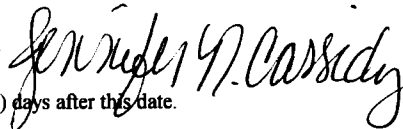
By 

*This certification must be surrendered to the Clerk of the Circuit Court no later than ten (10) days after this date.
05-0432-000 2016

APPLICATION FOR TAX DEED

Section 197.502, Florida Statutes

512
R. 12/16

Application Number: 1800114

To: Tax Collector of ESCAMBIA COUNTY, Florida

I,
MTAG AS CUSTODIAN FOR CAZ CREEK FLORIDA II, LLC
PO BOX 54900
NEW ORLEANS, LA 70154,

hold the listed tax certificate and hereby surrender the same to the Tax Collector and make tax deed application thereon:

Account Number	Certificate No.	Date	Legal Description
05-0432-000	2016/1991	06-01-2016	LT 11 BLK 3 2ND ADDN HIGHLAND TERRACE PB 3 P 37/51 /59 OR 6029 P 59

I agree to:

- pay any current taxes, if due and
- redeem all outstanding tax certificates plus interest not in my possession, and
- pay all delinquent and omitted taxes, plus interest covering the property.
- pay all Tax Collector's fees, ownership and encumbrance report costs, Clerk of the Court costs, charges and fees, and Sheriff's costs, if applicable.

Attached is the tax sale certificate on which this application is based and all other certificates of the same legal description which are in my possession.

Electronic signature on file
MTAG AS CUSTODIAN FOR CAZ CREEK FLORIDA II,
LLC
PO BOX 54900
NEW ORLEANS, LA 70154

04-25-2018
Application Date

Applicant's signature



Chris Jones Escambia County Property Appraiser

Real Estate Search

Tangible Property Search

Sale List

Amendment 1/Portability Calculations

[Back](#)

Navigate Mode
 Account
 Reference

[Printer Friendly Version](#)

General Information	
Reference:	042S302050011003
Account:	050432000
Owners:	NUNES JOSE
Mail:	820 S HWY 97 CANTONMENT, FL 32533
Situs:	128 W HIGHLAND DR 32503
Use Code:	SINGLE FAMILY RESID
Taxing Authority:	PENSACOLA CITY LIMITS
Schools (Elem/Int/High):	OJ SEMMES/FERRY PASS/WASHINGTON
Tax Inquiry:	Open Tax Inquiry Window
Tax Inquiry link courtesy of Scott Lunsford Escambia County Tax Collector	

Assessments				
Year	Land	Imprv	Total	Cap Val
2017	\$14,250	\$41,745	\$55,995	\$55,995
2016	\$14,250	\$42,414	\$56,664	\$56,664
2015	\$14,250	\$40,108	\$54,358	\$54,358

[Disclaimer](#)

[Amendment 1/Portability Calculations](#)

➤ [File for New Homestead Exemption Online](#)

Sales Data					
Sale Date	Book	Page	Value	Type	Official Records (New Window)
11/2006	6029	59	\$31,000	TD	View Instr
03/1995	3744	511	\$34,500	WD	View Instr
01/1991	2967	411	\$6,900	WD	View Instr
09/1981	1578	750	\$29,250	WD	View Instr

Official Records Inquiry courtesy of Pam Childers
Escambia County Clerk of the Circuit Court and Comptroller

2017 Certified Roll Exemptions
None

Legal Description
LT 11 BLK 3 2ND ADDN HIGHLAND TERRACE PB 3 P 37/51/59 OR 6029 P 59

Extra Features
None

Parcel Information [Launch Interactive Map](#)

Section Map Id:
04-2S-30-2

Approx. Acreage:
0.2085

Zoned:
R-1AA

Evacuation & Flood Information
[Open Report](#)

[View Florida Department of Environmental Protection \(DEP\) Data](#)

Buildings

Address: 128 W HIGHLAND DR, Year Built: 1955, Effective Year: 1955

Structural Elements
 DECOR/HILLWORK-AVERAGE
 DWELLING UNITS
 EXTERIOR WALL-CONCRETE BLOCK
 FLOOR COVER-ASPHALT TILE

FOUNDATION-SLAB ON GRADE
HEAT/AIR-WALL/FLOOR FURN
INTERIOR WALL-DRYWALL-PLASTER
NO. PLUMBING FIXTURES-6
NO. STORIES-1
ROOF COVER-COMPOSITION SHG
ROOF FRAMING-GABLE
STORY HEIGHT-0
STRUCTURAL FRAME-MASONRY
 PIL/STL

Areas - 1768 Total SF
BASE AREA - 1448
CARPORT UNF - 220
OPEN PORCH UNF - 56
UTILITY UNF - 44

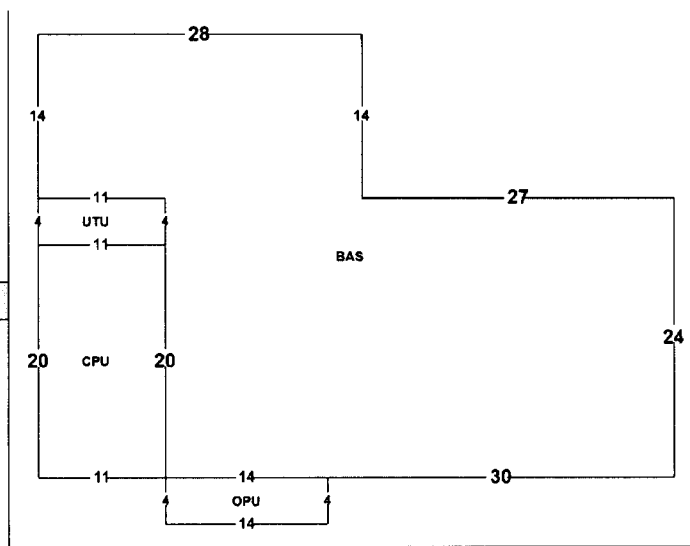

Images



8/23/17



8/23/17

The primary use of the assessment data is for the preparation of the current year tax roll. No responsibility or liability is assumed for inaccuracies or errors.

Last Updated:05/01/2018 (tc.3294)

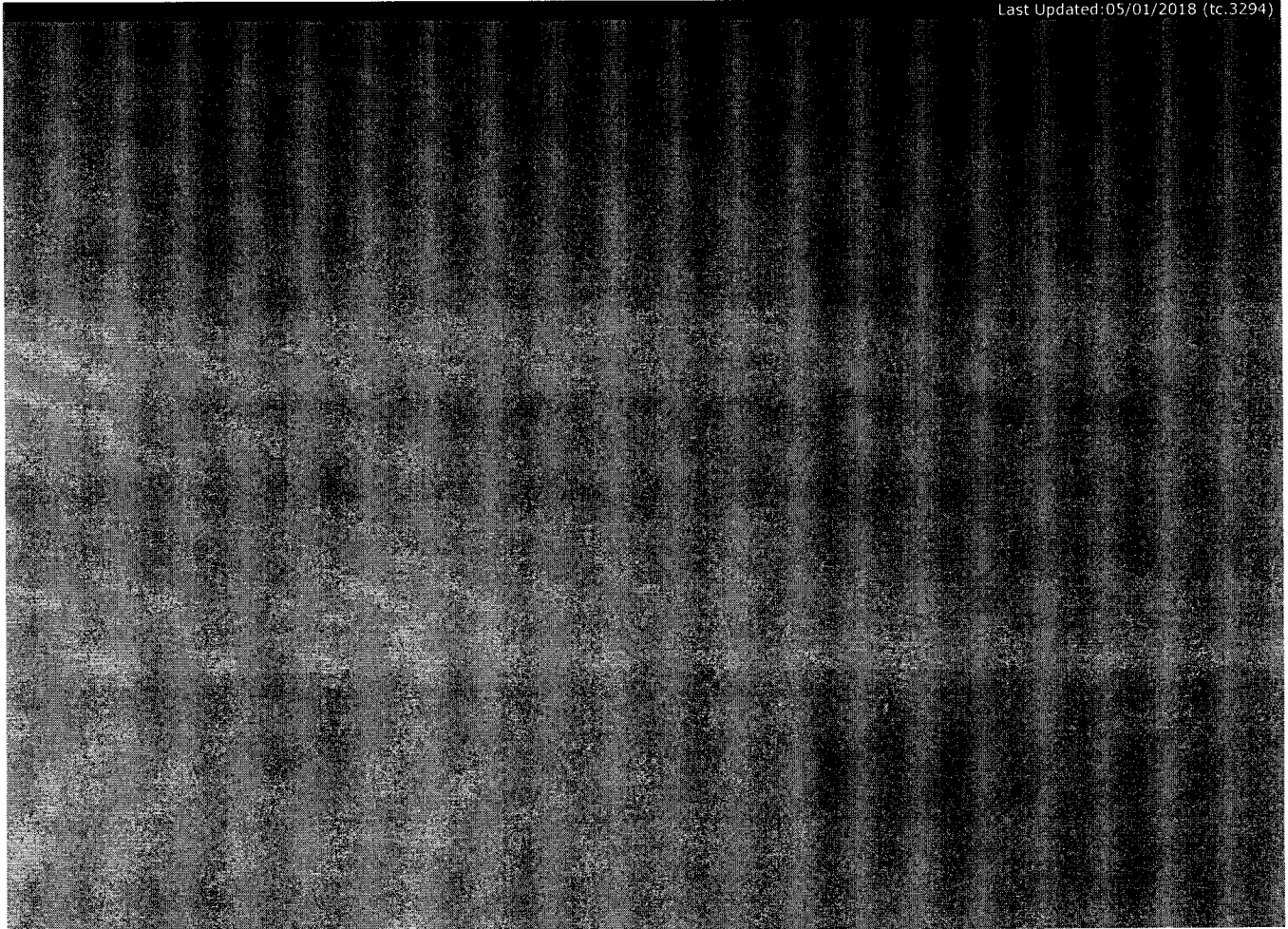

18-276

Southern Guaranty Title Company

4400 Bayou Boulevard, Suite 13B

Pensacola, Florida 32503

Telephone: 850-478-8121

Facsimile: 850-476-1437

PROPERTY INFORMATION REPORT

File No.: 14274

May 4, 2018

Escambia County Tax Collector

P.O. Box 1312

Pensacola, Florida 32591

Pursuant to your request, the Company has caused a search to be made of the Public Records of Escambia County, Florida, solely as revealed by records maintained from 04-30-1998, through 04-30-2018, and said search reveals the following:

1. THE GRANTEE(S) OF THE LAST DEED(S) OF RECORD IS:

Jose Nunes

2. The land covered by this Report is:

LEGAL DESCRIPTION IS ATTACHED HERETO AND MADE A PART HEREOF

3. The following unsatisfied mortgages, liens and judgments affecting the land covered by this Report appear of record:

SEE CONTINUATION PAGE ATTACHED HERETO AND MADE A PART HEREOF

4. Taxes:

SEE CONTINUATION PAGE ATTACHED HERETO AND MADE A PART HEREOF

This report is not title insurance. Pursuant to s. 627.7843, Florida Statutes, the maximum liability of the issuer of this property information report for errors or omissions in this property information report is limited to the amount paid for this property information report, and is further limited to the person(s) expressly identified by name in the property information report as the recipients(s) of the property information report.

THIS REPORT SHALL NOT BE USED FOR THE ISSUANCE OF TITLE INSURANCE.

Southern Guaranty Title Company

By: 

May 4, 2018

**PROPERTY INFORMATION REPORT
LEGAL DESCRIPTION**

File No.: 14274

May 4, 2018

Lot 11, Block 3, Second Addition to Highland Terrace, as per plat thereof, recorded in Plat Book 3, Page 59, of the Public Records of Escambia County, Florida

**PROPERTY INFORMATION REPORT
CONTINUATION PAGE**

File No.: 14274

May 4, 2018

UNSATISFIED MORTGAGES, LIENS AND JUDGMENTS AFFECTING THE LAND COVERED BY THIS REPORT THAT APPEAR OF RECORD:

1. Taxes for the year 2015-2017 delinquent. The assessed value is \$55,995.00. Tax ID 05-0432-000.

PLEASE NOTE THE FOLLOWING:

- A. Subject to current year taxes.
- B. Taxes and assessments due now or in subsequent years.
- C. Subject to Easements, Restrictions and Covenants of record.
- D. Encroachments, overlaps, boundary line disputes, and any other matters which would be disclosed by an accurate survey and inspection of the premises.
- E. Oil, gas and mineral or any other subsurface rights of any kind or nature.

SOUTHERN GUARANTY TITLE COMPANY

4400 BAYOU BLVD., SUITE 13-B, CORDOVA SQUARE

PENSACOLA, FLORIDA 32503

TEL. (850) 478-8121 FAX (850) 476-1437

Email: rcsqt@aol.com

Scott Lunsford
Escambia County Tax Collector
P.O. Box 1312
Pensacola, FL 32591

CERTIFICATION: TITLE SEARCH FOR TDA

TAX DEED SALE DATE: 8-6-2018

TAX ACCOUNT NO.: 05-0432-000

CERTIFICATE NO.: 2016-1991

In compliance with Section 197.256, Florida Statutes, the following is a list of names and addresses of those persons, firms and/or agencies having legal interest in or claim against the above described property. The above referenced tax sale certificate is being submitted as proper notification of tax deed sale.

YES NO

Notify City of Pensacola, P.O. Box 12910, 32521

Notify Escambia County, 190 Governmental Center, 32502

Homestead for _____ tax year.

Jose Nunes
820 S. Hwy. 97
Cantonment, FL 32533

Unknown Tenants
128 W. Highland Dr.
Pensacola, FL 32503

Certified and delivered to Escambia County Tax Collector,
this 4th day of May, 2018.

SOUTHERN GUARANTY TITLE COMPANY

by: Richard S. Combs, President

NOTE: The above listed addresses are based upon current information available, but said addresses are not guaranteed to be true or correct.

This instrument was prepared by:
Ernie Lee Magaha, Clerk of the Circuit Court
Escambia County Courthouse
Pensacola, Florida

Tax Deed File No. 06-181
Property Identification No. 042S302050011003
Tax Account No. 050432000

TAX DEED

State of Florida
County of Escambia

The following Tax Sale Certificate Numbered 02162 issued on June 1, 2004 was filed in the office of the tax collector of this County and application made for the issuance of a tax deed, the applicant having paid or redeemed all other taxes or tax sale certificates on the land described as required by law to be paid or redeemed, and the costs and expenses of this sale, and due notice of sale having been published as required by law, and no person entitled to do so having appeared to redeem said land; such land was on the 6th day of November 2006, offered for sale as required by law for cash to the highest bidder and was sold to: JOSE NUNES, 820 S HWY 97 CANTONMENT FL 32533, being the highest bidder and having paid the sum of his bid as required by the Laws of Florida.

Now, on this 6th day of November 2006, in the County of Escambia, State of Florida, in consideration of the sum of (\$31,000.00) THIRTY ONE THOUSAND AND 00/100 Dollars, being the amount paid pursuant to the Laws of Florida does hereby sell the following lands, including any hereditaments, buildings, fixtures and improvements of any kind and description, situated in the County and State aforesaid and described as follows:

LT 11 BLK 3 2ND ADDN HIGHLAND TERRACE PB 3 P 37/51/59 OR 3744 P 511

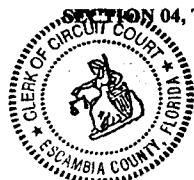

Ernie Lee Magaha
ERNIE LEE MAGAHA, Clerk of the Circuit Court
Escambia County, Florida

Gloria W. Gatson
witness Gloria W. Gatson
Rebecca C. Cowan
witness Rebecca C. Cowan

State of Florida
County of Escambia

On this 6th day of November 2006, before me Gloria W. Gatson personally appeared Ernie Lee Magaha, Clerk of the Circuit Court in and for the State and this County known to me to be the person described in, and who executed the foregoing instrument, and acknowledged the execution of this instrument to be his own free act and deed for the use and purposes therein mentioned.

Witness my hand and official seal date aforesaid.

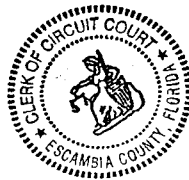

ERNIE LEE MAGAHA, Clerk of the Circuit Court

By: *Gloria W. Gatson*
Gloria W. Gatson, Deputy Clerk

PAM CHILDERS
 CLERK OF THE CIRCUIT COURT
 ARCHIVES AND RECORDS
 CHILDSUPPORT
 CIRCUIT CIVIL
 CIRCUIT CRIMINAL
 COUNTY CIVIL
 COUNTY CRIMINAL
 DOMESTIC RELATIONS
 FAMILY LAW
 JURY ASSEMBLY
 JUVENILE
 MENTAL HEALTH
 MIS
 OPERATIONAL SERVICES
 PROBATE
 TRAFFIC



11 17 1820: 11 17 1820

**COUNTY OF ESCAMBIA
 OFFICE OF THE
 CLERK OF THE CIRCUIT COURT**

**BRANCH OFFICES
 ARCHIVES AND RECORDS
 JUVENILE DIVISION
 CENTURY**

CLERK TO THE BOARD OF
 COUNTY COMMISSIONERS
 OFFICIAL RECORDS
 COUNTY TREASURY
 AUDITOR

**PAM CHILDERS, CLERK OF THE CIRCUIT COURT
 Tax Certificate Redeemed From Sale
 Account: 050432000 Certificate Number: 001991 of 2016**

Payor: JOSE NUNES 820 S HWY 97 CANTONMENT, FL 32533 Date 06/15/2018

Clerk's Check #	1	Clerk's Total	\$477.00	\$4325.42
Tax Collector Check #	1	Tax Collector's Total	\$4,308.54	
		Postage	\$10.84	
		Researcher Copies	\$1.00	
		Total Received	\$4,792.38	\$4326.42

**PAM CHILDERS
 Clerk of the Circuit Court**

Received By:
 Deputy Clerk

Escambia County Government Complex • 221 Palafox Place Ste 110 • PENSACOLA, FLORIDA 32502
 (850) 595-3793 • FAX (850) 595-4827 • <http://www.clerk.co.escambia.fl.us>

PAM CHILDERS
 CLERK OF THE CIRCUIT COURT
 ARCHIVES AND RECORDS
 CHILDSUPPORT
 CIRCUIT CIVIL
 CIRCUIT CRIMINAL
 COUNTY CIVIL
 COUNTY CRIMINAL
 DOMESTIC RELATIONS
 FAMILY LAW
 JURY ASSEMBLY
 JUVENILE
 MENTAL HEALTH
 MIS
 OPERATIONAL SERVICES
 PROBATE
 TRAFFIC



BRANCH OFFICES
ARCHIVES AND RECORDS
JUVENILE DIVISION
CENTURY

CLERK TO THE BOARD OF
 COUNTY COMMISSIONERS
 OFFICIAL RECORDS
 COUNTY TREASURY
 AUDITOR

COUNTY OF ESCAMBIA
OFFICE OF THE
CLERK OF THE CIRCUIT COURT

Case # 2016 TD 001991

Redeemed Date 06/15/2018

Name JOSE NUNES 820 S HWY 97 CANTONMENT, FL 32533

Clerk's Total = TAXDEED	\$477.00	\$4325.42
Due Tax Collector = TAXDEED	\$4,303.54	
Postage = TD2	\$10.84	
ResearcherCopies = TD6	\$1.00	

• For Office Use Only

Date	Docket	Desc	Amount Owed	Amount Due	Payee Name
------	--------	------	-------------	------------	------------

FINANCIAL SUMMARY

No Information Available - See Dockets



PAM CHILDERS
CLERK OF THE CIRCUIT COURT
ESCAMBIA COUNTY, FLORIDA

Tax Deed - Redemption Calculator
Account: 050432000 Certificate Number: 001991 of 2016

Redemption No Application Date Interest Rate

	Final Redemption Payment ESTIMATED	Redemption Overpayment ACTUAL
	Auction Date <input type="text" value="08/06/2018"/>	Redemption Date <input type="text" value="06/15/2018"/>
Months	4	2
Tax Collector	<input type="text" value="\$4,054.05"/>	<input type="text" value="\$4,054.05"/>
Tax Collector Interest	\$243.24	\$121.62
Tax Collector Fee	<input type="text" value="\$6.25"/>	<input type="text" value="\$6.25"/>
Total Tax Collector	\$4,303.54	<input type="text" value="\$4,181.92"/> <i>TC</i>
Clerk Fee	<input type="text" value="\$130.00"/>	<input type="text" value="\$130.00"/>
Sheriff Fee	<input type="text" value="\$120.00"/>	<input type="text" value="\$120.00"/>
Legal Advertisement	<input type="text" value="\$200.00"/>	<input type="text" value="\$200.00"/>
App. Fee Interest	\$27.00	\$13.50
Total Clerk	\$477.00	<input type="text" value="\$463.50"/> <i>CH</i>
Postage	<input type="text" value="\$10.84"/>	<input type="text" value="\$0.00"/>
Researcher Copies	<input type="text" value="\$1.00"/>	<input type="text" value="\$1.00"/>
Total Redemption Amount	\$4,792.38	\$4,646.42
	Repayment Overpayment Refund Amount	\$145.96

Notes

**STATE OF FLORIDA
COUNTY OF ESCAMBIA**

**CERTIFICATE OF NOTICE OF MAILING
NOTICE OF APPLICATION FOR TAX DEED**

CERTIFICATE # 01991 of 2016

I, PAM CHILDERS, CLERK OF THE CIRCUIT COURT OF ESCAMBIA COUNTY, FLORIDA, do hereby certify that I did on June 21, 2018, mail a copy of the foregoing Notice of Application for Tax Deed, addressed to:

JOSE NUNES 820 S HWY 97 CANTONMENT, FL 32533	JOSE NUNES C/O TENANTS 128 W HIGHLAND DR PENSACOLA FL 32503
--	--

WITNESS my official seal this 21th day of June 2018.



PAM CHILDERS
CLERK OF THE CIRCUIT COURT
ESCAMBIA COUNTY, FLORIDA

By:
Emily Hogg
Deputy Clerk

WARNING

THERE ARE UNPAID TAXES ON PROPERTY WHICH YOU OWN OR IN WHICH YOU HAVE A LEGAL INTEREST. THE PROPERTY WILL BE SOLD AT PUBLIC AUCTION ON August 6, 2018, UNLESS THE TAXES ARE PAID. SHOULD YOU NEED FURTHER INFORMATION CONTACT THE CLERK OF THE CIRCUIT COURT IMMEDIATELY AT THE COUNTY COURTHOUSE IN PENSACOLA, FLORIDA, OR CALL 850-595-3793.

NOTICE OF APPLICATION FOR TAX DEED

NOTICE IS HEREBY GIVEN, That MTAG AS CUSTODIAN FOR CAZ CREEK FLORIDA II LLC holder of Tax Certificate No. 01991, issued the 1st day of June, A.D., 2016 has filed same in my office and has made application for a tax deed to be issued thereon. Said certificate embraces the following described property in the County of Escambia, State of Florida, to wit:

LT 11 BLK 3 2ND ADDN HIGHLAND TERRACE PB 3 P 37/51/59 OR 6029 P 59

SECTION 04, TOWNSHIP 2 S, RANGE 30 W

TAX ACCOUNT NUMBER 050432000 (18-276)

The assessment of the said property under the said certificate issued was in the name of

JOSE NUNES

Unless said certificate shall be redeemed according to law, the property described therein will be sold to the highest bidder at public auction at 9:00 A.M. on the first Monday in the month of August, which is the 6th day of August 2018.

Dated this 21st day of June 2018.

In accordance with the AMERICANS WITH DISABILITIES ACT, if you are a person with a disability who needs special accommodation in order to participate in this proceeding you are entitled to the provision of certain assistance. Please contact Emily Hogg not later than seven days prior to the proceeding at Escambia County Government Complex, 221 Palafox Place Ste 110, Pensacola FL 32502. Telephone: 850-595-3793.



PAM CHILDERS
CLERK OF THE CIRCUIT COURT
ESCAMBIA COUNTY, FLORIDA

By:
Emily Hogg
Deputy Clerk



Pam Childers

Clerk of the Circuit Court and Comptroller, Escambia County

Clerk of Courts • County Comptroller • Clerk of the Board of County Commissioners • Recorder •

June 25, 2018

MTAG AS CUSTODIAN FOR CAZ CREEK FLORIDA II
PO BOX 54900
NEW ORLEANS LA 70154

Dear Certificate Holder:

The records of this office show that an application for a tax deed had been made on the property represented by the numbered certificate listed below. The property redeemed prior to sale; therefore your application fees are now refundable.

TAX CERT	APP FEES	INTEREST	TOTAL
2016 TD 001991	\$450.00	\$13.50	\$463.50
2016 TD 004769	\$450.00	\$13.50	\$463.50
2016 TD 004187	\$450.00	\$13.50	\$463.50
2016 TD 008247	\$450.00	\$13.50	\$463.50

TOTAL \$1,854.00

Very truly yours,

PAM CHILDERS
Clerk of Circuit Court

By:

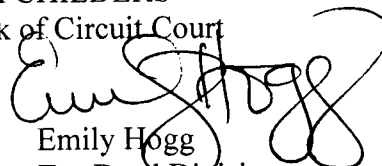
Emily Hogg
Tax Deed Division