

Tax Collector's Certification

CTY-513

Tax Deed Application Number
1600382

Date of Tax Deed Application
May 04, 2016

This is to certify that **PFS FINANCIAL 1, LLC U.S. BANK, CUSTODIAN/PFS FINAN US BANK AS CUST FOR PFS FINANCIAL 1 LLC**, holder of **Tax Sale Certificate Number 2014 / 8046**, Issued the 1st Day of June, 2014 and which encumbers the following described property in the county of Escambia, State of Florida, to wit: **12-2727-000**

Cert Holder:
PFS FINANCIAL 1, LLC U.S. BANK, CUSTODIAN/PFS FINAN
US BANK AS CUST FOR PFS FINANCIAL 1 LLC
50 SOUTH 16TH ST, STE 2050
PHILADELPHIA, PA 19102

Property Owner:
DILLER KELVIN E & CONSTANCE R
4870 HWY 97
WALNUT HILL, FL 32568

N1/2 OF NW1/4 OF SE1/4 LESS STATE RD 97 RD R/W OR 1923 P
243/244

has surrendered same in my office and made written application for tax deed in accordance with Florida Statutes. I certify that the following tax certificates, interest, ownership and encumbrance report fee, and Tax Collector's fees have been paid, or if the certificate is held by the County, all appropriate fees have been deposited.

Certificates owned by applicant and filed in connection with this application:

Certificate Year/Number	Account Number	Sale Date	Face Amount of Certificate	Interest	Total
2014/8046	12-2727-000	06-01-2014	2,862.68	143.13	3,005.81

Certificates redeemed by applicant or included (County) in connection with this tax deed application:

Certificate Year/Number	Account Number	Sale Date	Face Amount of Certificate	Tax Collector's Fee	Interest	Total
2015/8464	12-2727-000	06-01-2015	2,864.59	6.25	143.23	3,014.07

Amounts Certified by Tax Collector (Lines 1-7):

1. Total of all Certificates in Applicant's Possession and Cost of the Certificates Redeemed by Applicant	6,019.88
2. Total of Delinquent Taxes Paid by Tax Deed Applicant	0.00
3. Total of Current Taxes Paid by Tax Deed Applicant	2655.39
4. Ownership and Encumbrance Report Fee	200.00
5. Tax Deed Application Fee	175.00
6. Total Interest Accrued by Tax Collector Pursuant to Section 197.542, F.S.	
7. Total (Lines 1 - 6)	9,050.27

Amounts Certified by Clerk of Court (Lines 8-15):

8. Clerk of Court Statutory Fee for Processing Tax Deed	
9. Clerk of Court Certified Mail Charge	
10. Clerk of Court Advertising Charge	
11. Clerk of Court Recording Fee for Certificate of Notice	
12. Sheriff's Fee	
13. Interest Computed by Clerk of Court Pursuant to Section 197.542, F.S.	
14. Total (Lines 8 - 13)	
15. One-half Assessed Value of Homestead Property, if Applicable per F.S.	101,384.00
16. Other Outstanding Certificates and Delinquent Taxes Not Included in this Application, If Applicable Per Florida Statutes	
17. Statutory (Opening) Bid; Total of Lines 7, 14, 15 (if applicable) and 16 (if applicable)	
18. Redemption Fee	6.25
19. Total Amount to Redeem	

Done this the 24th day of May, 2016 Janet Holley, Tax Collector of Escambia County.

Date of Sale: 5 December 2016

By *Shirley Rich, CFA*
Senior Deputy Tax Collector

*This certification must be surrendered to the Clerk of the Circuit Court no later than ten (10) days after this date.
12-2727-000 2014

TO: Tax Collector of ESCAMBIA COUNTY: JANET HOLLEY

In accordance with the Florida Statutes, I, PFS FINANCIAL 1, LLC U.S. BANK, CUSTODIAN/PFS FINAN
US BANK AS CUST FOR PFS FINANCIAL 1 LLC
50 SOUTH 16TH ST, STE 2050
PHILADELPHIA, PA 19102

, holder of the following tax sale certificate hereby surrender same to the Tax Collector and make tax deed application thereon:

Certificate No.	Date	Legal Description
2014/ 8046	06-01-2014	N1/2 OF NW1/4 OF SE1/4 LESS STATE RD 97 RD R/W OR 1923 P 243/244

I agree to pay all delinquent taxes, redeem all outstanding tax certificates not in my possession, pay any omitted taxes, and pay current taxes, if due, covering the land, and pay any interest earned (a) on tax certificates not in my possession, (b) on omitted taxes or (c) on delinquent taxes. I also agree to pay all tax collector's fees, ownership and encumbrance report costs, clerk of the court costs, charges and fees and sheriff's costs, if applicable. Attached is the above- mentioned tax sale certificate on which this application is based and all other certificates of the same legal description which are in my possession.

Electronic signature on file

Applicant's Signature

05-04-2016

Date



Chris Jones Escambia County Property Appraiser

- Real Estate Search
- Tangible Property Search
- Sale List
- Amendment 1/Portability Calculations

[Back](#)

◀ Navigate Mode Account Reference ▶

[Printer Friendly Version](#)

General Information	
Reference:	394N324220000000
Account:	122727000
Owners:	DILLER KELVIN E & CONSTANCE R
Mail:	4870 HWY 97 WALNUT HILL, FL 32568
Situs:	4870 HIGHWAY 97 32568
Use Code:	IMPROV. AGRICULTURAL-RESIDENTIAL
Taxing Authority:	COUNTY MSTU
Tax Inquiry:	Open Tax Inquiry Window
Tax Inquiry link courtesy of Janet Holley Escambia County Tax Collector	

Assessments				
Year	Land	Imprv	Total	Cap Val
2015	\$16,316	\$215,209	\$231,525	\$202,768
2014	\$19,426	\$205,786	\$225,212	\$204,316
2013	\$19,426	\$182,004	\$201,430	\$201,430

[Disclaimer](#)

[Amendment 1/Portability Calculations](#)

Sales Data					
Sale Date	Book	Page	Value	Type	Official Records (New Window)
06/1984	1923	244	\$92,500	WD	View Instr
06/1984	1923	243	\$67,000	OT	View Instr
01/1977	1122	575	\$62,000	WD	View Instr

Official Records inquiry courtesy of Pam Childers
Escambia County Clerk of the Circuit Court and Comptroller

2015 Certified Roll Exemptions
HOMESTEAD EXEMPTION

Legal Description
N1/2 OF NW1/4 OF SE1/4 AND N1/2 OF NE1/4 OF SE1/4
LESS STATE RD 97 RD R/W OR 1923 P 243/244

Extra Features
MOBILE HOME

Parcel Information [Launch Interactive Map](#)

Section
Map Id:
39-4N-32

Approx. Acreage:
39.2400

Zoned:
Agr

Evacuation & Flood Information
[Open Report](#)

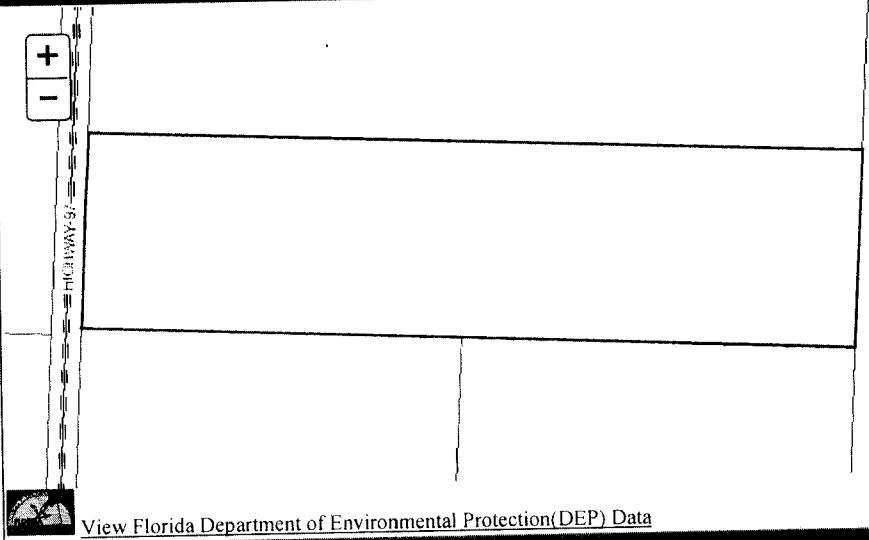

[View Florida Department of Environmental Protection \(DEP\) Data](#)

Buildings

Address: 4870 HIGHWAY 97, Year Built: 1963, Effective Year: 1970

Structural Elements
DECOR/MILLWORK-ABOVE AVERAGE
DWELLING UNITS-1
EXTERIOR WALL-BRICK-FACE/VENEER
FLOOR COVER-CARPET
FOUNDATION-SLAB ON GRADE
HEAT/AIR-CENTRAL H/AC
INTERIOR WALL-DRYWALL-PLASTER
INTERIOR WALL-PANEL-PLYWOOD

NO. PLUMBING FIXTURES-12
NO. STORIES-2
ROOF COVER-DIMEN/ARCH SHNG
ROOF FRAMING-GABLE-HI PITCH
STORY HEIGHT-0
STRUCTURAL FRAME-WOOD FRAME

Areas - 5971 Total SF
BASE AREA - 3735
CARPORT FIN - 979
OPEN PORCH FIN - 326
UPPER STORY FIN - 931

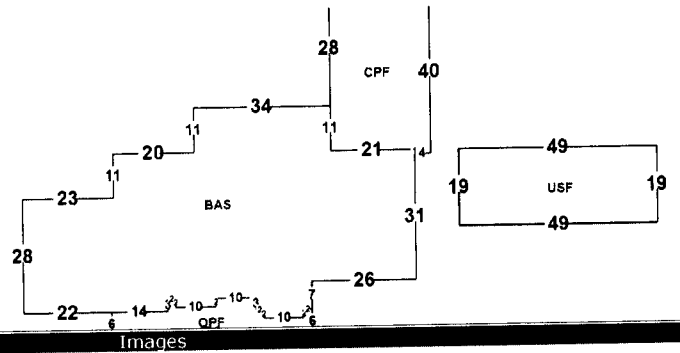

7/8/13



7/8/13

The primary use of the assessment data is for the preparation of the current year tax roll. No responsibility or liability is assumed for inaccuracies or errors.

PAM CHILDERS
 CLERK OF THE CIRCUIT COURT
 ARCHIVES AND RECORDS
 CHILDSUPPORT
 CIRCUIT CIVIL
 CIRCUIT CRIMINAL
 COUNTY CIVIL
 COUNTY CRIMINAL
 DOMESTIC RELATIONS
 FAMILY LAW
 JURY ASSEMBLY
 JUVENILE
 MENTAL HEALTH
 MIS
 OPERATIONAL SERVICES
 PROBATE
 TRAFFIC



BRANCH OFFICES
ARCHIVES AND RECORDS
JUVENILE DIVISION
CENTURY

CLERK TO THE BOARD OF
 COUNTY COMMISSIONERS
 OFFICIAL RECORDS
 COUNTY TREASURY
 AUDITOR

COUNTY OF ESCAMBIA
OFFICE OF THE
CLERK OF THE CIRCUIT COURT

PAM CHILDERS, CLERK OF THE CIRCUIT COURT
Tax Certificate Redeemed From Sale
Account: 122727000 Certificate Number: 008046 of 2014

Payor: KELVIN DILLER 4870 HWY 97 WALNUT HILL FL 32568 Date 06/15/2016

Clerk's Check #	516766	Clerk's Total	\$497.25
Tax Collector Check #	1	Tax Collector's Total	\$10,006.80
		Postage	\$60.00
		Researcher Copies	\$40.00
		Total Received	\$10,604.05

9829.02
~~\$9649.02~~

PAM CHILDERS
 Clerk of the Circuit Court

Received By:
 Deputy Clerk

A large, stylized handwritten signature in black ink, likely belonging to the Deputy Clerk mentioned in the text.

Escambia County Government Complex • 221 Palafox Place Ste 110 • PENSACOLA, FLORIDA 32502
 (850) 595-3793 • FAX (850) 595-4827 • <http://www.clerk.co.escambia.fl.us>

PAM CHILDERS
 CLERK OF THE CIRCUIT COURT
 ARCHIVES AND RECORDS
 CHILDSUPPORT
 CIRCUIT CIVIL
 CIRCUIT CRIMINAL
 COUNTY CIVIL
 COUNTY CRIMINAL
 DOMESTIC RELATIONS
 FAMILY LAW
 JURY ASSEMBLY
 JUVENILE
 MENTAL HEALTH
 MIS
 OPERATIONAL SERVICES
 PROBATE
 TRAFFIC



BRANCH OFFICES
ARCHIVES AND RECORDS
JUVENILE DIVISION
CENTURY

CLERK TO THE BOARD OF
 COUNTY COMMISSIONERS
 OFFICIAL RECORDS
 COUNTY TREASURY
 AUDITOR

COUNTY OF ESCAMBIA
OFFICE OF THE
CLERK OF THE CIRCUIT COURT

Case # 2014 TD 008046
Redeemed Date 06/15/2016

Name KELVIN DILLER 4870 HWY 97 WALNUT HILL FL 32568

Clerk's Total = TAXDEED	\$497.25	<i>9329.07</i> <i>9649.07</i>
Due Tax Collector = TAXDEED	\$10,006.80	
Postage = TD2	\$60.00	
ResearcherCopies = TD6	\$40.00	

• For Office Use Only

Date	Docket	Desc	Amount Owed	Amount Due	Payee Name
------	--------	------	-------------	------------	------------

FINANCIAL SUMMARY

No Information Available - See Dockets



PAM CHILDERS
CLERK OF THE CIRCUIT COURT
ESCAMBIA COUNTY, FLORIDA

Tax Deed - Redemption Calculator
Account: 122727000 Certificate Number: 008046 of 2014

Redemption Yes
 Application Date
 Interest Rate

	Final Redemption Payment ESTIMATED	Redemption Overpayment ACTUAL
	Auction Date <input type="text" value="12/05/2016"/>	Redemption Date <input type="text" value="06/15/2016"/>
Months	7	1
Tax Collector	<input type="text" value="\$9,050.27"/>	<input type="text" value="\$9,050.27"/>
Tax Collector Interest	\$950.28	\$135.75
Tax Collector Fee	<input type="text" value="\$6.25"/>	<input type="text" value="\$6.25"/>
Total Tax Collector	\$10,006.80	<input type="text" value="\$9,192.27"/> TC
Clerk Fee	<input type="text" value="\$130.00"/>	<input type="text" value="\$130.00"/>
Sheriff Fee	<input type="text" value="\$120.00"/>	<input type="text" value="\$120.00"/>
Legal Advertisement	<input type="text" value="\$200.00"/>	<input type="text" value="\$200.00"/>
App. Fee Interest	\$47.25	\$6.75
Total Clerk	\$497.25	<input type="text" value="\$456.75"/> CH
Postage	<input type="text" value="\$60.00"/>	<input type="text" value="\$0.00"/>
Researcher Copies	<input type="text" value="\$40.00"/>	<input type="text" value="\$0.00"/>
Total Redemption Amount	\$10,604.05	\$9,649.02
	Repayment Overpayment Refund Amount	\$955.03

Notes



Pam Childers

Clerk of the Circuit Court and Comptroller, Escambia County

Clerk of Courts • County Comptroller • Clerk of the Board of County Commissioners • Recorder •

June 24, 2016

PFS FINANCIAL 1 LLC US BANK CUSTODIAN/PFS FINAN US BANK AS CUST FOR PFS
FINANCIAL 1 LLC
50 SOUTH 16TH ST STE 2050
PHILADELPHIA PA 19102

Dear Certificate Holder:

The records of this office show that an application for a tax deed had been made on the property represented by the numbered certificate listed below. The property redeemed prior to sale; therefore your application fees are now refundable.

TAX CERT	APP FEES	INTEREST	TOTAL
2014 TD 008046	\$450.00	\$6.75	\$456.75
2014 TD 001158	\$450.00	\$6.75	\$456.75

TOTAL \$913.50

Very truly yours,

PAM CHILDERS
Clerk of Circuit Court

By:

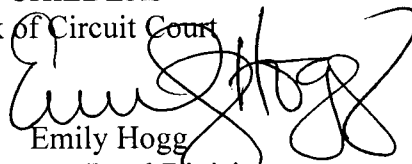
Emily Hogg
Tax Deed Division

Southern Guaranty Title Company

4400 Bayou Boulevard, Suite 13B
Pensacola, Florida 32503
Telephone: 850-478-8121
Facsimile: 850-476-1437

Redeemed
16-531

OWNERSHIP AND ENCUMBRANCE REPORT

File No.: 13116

September 16, 2016

Escambia County Tax Collector
P.O. Box 1312
Pensacola, Florida 32591

Pursuant to your request, the Company has caused a search to be made of the Public Records of Escambia County, Florida, solely as revealed by records maintained from 09-16-1996, through 09-16-2016, and said search reveals the following:

1. THE GRANTEE(S) OF THE LAST DEED(S) OF RECORD IS:

Kelvin E. Diller and Constance R. Diller, husband and wife

2. The land covered by this Report is:

LEGAL DESCRIPTION IS ATTACHED HERETO AND MADE A PART HEREOF

3. The following unsatisfied mortgages, liens and judgments affecting the land covered by this Report appear of record:

SEE CONTINUATION PAGE ATTACHED HERETO AND MADE A PART HEREOF

4. Taxes:

SEE CONTINUATION PAGE ATTACHED HERETO AND MADE A PART HEREOF

The foregoing report is prepared and furnished for information only, is not intended to constitute or imply any opinion, warranty, guaranty, insurance, or similar assurance as to the status of title, and no determination has been made of the authenticity of any instrument described or referred to herein. The name search for the purposes of determining applicable judgments and liens is limited to the apparent record owner(s) shown herein, No attempt has been made to determine whether the land is subject to liens or assessments which are not shown as existing liens by the public records. The Company's liability hereunder shall not exceed the cost of this Report, or \$1,000.00 whichever is less.

THIS REPORT SHALL NOT BE USED FOR THE ISSUANCE OF TITLE INSURANCE.

Southern Guaranty Title Company

By: 

September 16, 2016

**OWNERSHIP AND ENCUMBRANCE REPORT
LEGAL DESCRIPTION**

File No.: 13116

September 16, 2016

North 1/2 of Northwest 1/4 of Southeast 1/4 and North 1/2 of Northeast 1/4 of Southeast 1/4, less State Road 97 road right of way, Section 39, Township 4 North, Range 32 West, Escambia County, Florida.

**OWNERSHIP AND ENCUMBRANCE REPORT
CONTINUATION PAGE**

File No.: 13116

September 16, 2016

UNSATISFIED MORTGAGES, LIENS AND JUDGMENTS AFFECTING THE LAND COVERED BY THIS REPORT THAT APPEAR OF RECORD:

1. That certain mortgage executed by Kelvin E. Diller and Constance R. Diller, husband and wife in favor of UAP/Ga.Ag.Chem., Inc. dated 08/13/2002 and recorded 12/03/2002 in Official Records Book 5022, page 960 of the public records of Escambia County, Florida, in the original amount of \$650,000.00. NOTE: Mortgage encumbers several parcels.
2. That certain mortgage executed by Kelvin E. Diller and Constance R. Diller, husband and wife in favor of First National Bank of Atmore dated 10/11/2006 and recorded 12/12/2006 in Official Records Book 6048, page 530 of the public records of Escambia County, Florida, in the original amount of \$62,775.30.
3. That certain mortgage executed by Kelvin E. Diller and Constance R. Diller, husband and wife in favor of United Bank dated 05/11/2010 and recorded 05/26/2010 in Official Records Book 6595, page 1113 of the public records of Escambia County, Florida, in the original amount of \$119,270.18. NOTE: Mortgage encumbers several parcels.
4. Taxes for the year 2012-2015 delinquent. The assessed value is \$243,894.00. Tax ID 12-2727-000.

PLEASE NOTE THE FOLLOWING:

- A. Subject to current year taxes.
- B. Taxes and assessments due now or in subsequent years.
- C. Subject to Easements, Restrictions and Covenants of record.
- D. Encroachments, overlaps, boundary line disputes, and any other matters which would be disclosed by an accurate survey and inspection of the premises.
- E. Oil, gas and mineral or any other subsurface rights of any kind or nature.

SOUTHERN GUARANTY TITLE COMPANY

4400 BAYOU BLVD., SUITE 13-B, CORDOVA SQUARE

PENSACOLA, FLORIDA 32503

TEL. (850) 478-8121 FAX (850) 476-1437

Email: rcsqt@aol.com

Janet Holley
Escambia County Tax Collector
P.O. Box 1312
Pensacola, FL 32596

CERTIFICATION: TITLE SEARCH FOR TDA

TAX DEED SALE DATE: 12-5-2016

TAX ACCOUNT NO.: 12-2727-000

CERTIFICATE NO.: 2014
2013-8046

In compliance with Section 197.256, Florida Statutes, the following is a list of names and addresses of those persons, firms and/or agencies having legal interest in or claim against the above described property. The above referenced tax sale certificate is being submitted as proper notification of tax deed sale.

YES NO

Notify City of Pensacola, P.O. Box 12910, 32521

Notify Escambia County, 190 Governmental Center, 32502

Homestead for 2015 tax year.

Kelvin E. Diller
Constance R. Diller
4870 Hwy. 97
Walnut Hill, FL 32568

United Bank
P.O. Box 8
Atmore, AL 36504

UAP/Ga. Ag. Chem., Inc.
121 N. Westove Blvd.
Albany, GA 31707

First National Bank of Atmore
P.O. Box 27
Atmore, AL 36504

Certified and delivered to Escambia County Tax Collector,
this 16th day of September, 2016.

SOUTHERN GUARANTY TITLE COMPANY

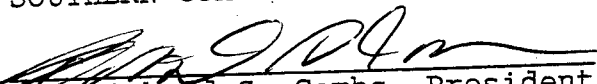
by: Richard S. Combs, President

NOTE: The above listed addresses are based upon current information available, but said addresses are not guaranteed to be true or correct.

301-50
5.00
306-50

STATE OF FLORIDA)
COUNTY OF ESCAMBIA)

PERSONAL REPRESENTATIVE'S DEED

KNOW ALL MEN BY THESE PRESENTS: That I, JAMES C. MASON, as Personal Representative of the Estate of Bessie S. Mason, Deceased, for and in consideration of the sum of Ten Dollars (\$10.00) and other good and valuable considerations, the receipt whereof is hereby acknowledged, do bargain, sell, convey and grant unto KELVIN E. DILLER and CONSTANCE R. DILLER, husband and wife, whose mailing address is Route 1, Box 177, Walnut Hill, Florida 32568, their heirs, executors, administrators and assigns, forever, the following described real property, situate, lying and being in the County of Escambia, State of Florida, to-wit:

PARCEL 1:
The North One-Half (1/2) of the Northeast One-Fourth (1/4) of the Southeast One-Fourth (1/4) of Section 39, Township 4 North, Range 32 West, (the Joel A. McDavid Donation).

296810

PARCEL 2:
All of the North One-Half (1/2) of the Northwest One-Fourth (1/4) of the Southeast One-Fourth (1/4) of Section 39, Township 4 North, Range 32 West, Escambia County, Florida, lying East of the previously described right-of-way of State Road No. 97, LESS AND EXCEPT the South 455 feet of the West 455 feet thereof.

FILED AND RECORDED IN
THE PUBLIC RECORDS OF
ESCAMBIA CO FLA. ON

JUN 11 1 39 PM '84

IN BOOK & PAGE NOTED ABOVE
JOE A. FLOWERS, COMPTROLLER
ESCAMBIA COUNTY

Subject to taxes for the year 1984 and subsequent years, restrictions, easements and oil, gas and mineral reservations of record.

Pursuant to Order of Escambia County Circuit Court Judge Jack H. Greenhut dated June 11, 1984.

Together with all and singular the tenements, hereditaments and appurtenances thereto belonging or in anywise appertaining, free from all exemptions and right of homestead.

IN WITNESS WHEREOF, I have hereunto set my hand and real this 11th day of June, 1984.

Signed, sealed and delivered in the presence of:

Michael D. Smith

Mary Janet Bradley

James C. Mason (SEAL)
JAMES C. MASON, as Personal Representative of the Estate of Bessie S. Mason, Deceased

STATE OF FLORIDA)
COUNTY OF ESCAMBIA)

Before the subscriber, personally appeared JAMES C. MASON, as Personal Representative of the Estate of Bessie S. Mason, Deceased, known to me, and known to me to be the individual described by said name in and who executed the foregoing instrument and acknowledged that he executed the same for the uses and purposes therein set forth.

Given under my hand and official seal this 11th day of June, 1984.

This instrument prepared by
MICHAEL D. SMITH
OF HARRILL, WILTSHIRE, STONE & SWEARINGEN
Attorneys at Law
201 East Government Street
PENSACOLA, FLORIDA 32501

Mary Janet Bradley
Notary Public
My Commission Expires: 12/21/85

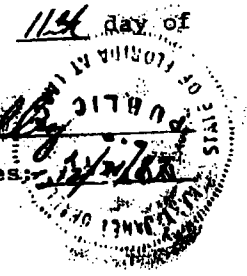

5.00
416.25
421.25

State of Florida }
Escambia County

WARRANTY DEED

Know All Men by These Presents: That we, WILLIAM E. COKER, JR. and ANITA MASON COKER, husband and wife,

for and in consideration of Ten Dollars (\$10.00) and other good and valuable considerations

the receipt whereof is hereby acknowledged, do bargain, sell, convey and grant unto KELVIN E. DILLER and CONSTANCE R. DILLER, husband and wife, whose mailing address is Route 1, Box 177, Walnut Hill, Florida 32568,

their heirs, executors, administrators and assigns, forever, the following described real property, situate, lying and being in the County of Escambia, State of Florida,
to-wit:

Begin at the point of intersection of the South line of the North 1/2 of the Northwest 1/4 of the Southeast 1/4 of Section 39, Township 4 North, Range 32 West, (the Joel A. McDavid Donation) and the Easterly right-of-way line of the 100 foot wide right-of-way of State Road No. 97 (Molino-Atmore Highway) for point of beginning and run Northerly along the said Highway line for 455 feet; thence East 455 feet; thence South 455 feet; thence West 455 feet, more or less, to said Point of Beginning.

Subject to taxes for the year 1984 and subsequent years, restrictions, easements and oil, gas and mineral reservations of record.

FILED AND RECORDED
IN THE PUBLIC RECORDS
OF ESCAMBIA COUNTY, FLA.
JUN 11 1 37 PM '84
29681

Together with all and singular the tenements, hereditaments and appurtenances thereto in anywise appertaining, free from all exemptions and right of homestead.

And we covenant that we are well seized of an indefeasible estate in fee simple in the said property, and have a good right to convey the same; that it is free of lien or encumbrance, and that OUR heirs, executors and administrators, the said grantee S their heirs, executors, administrators and assigns, in the quiet and peaceable possession and enjoyment thereof, against all persons lawfully claiming the same, shall and will forever warrant and defend.

IN WITNESS WHEREOF, we have hereunto set OUR hands and seals this 11th day of June, A. D. 1984.

Signed, sealed and delivered in the presence of
Michael D. Smith
Mary Janet Bradley

William E. Coker Jr (SEAL)
WILLIAM E. COKER, JR. (SEAL)
Anita Mason Coker (SEAL)
ANITA MASON COKER (SEAL)

State of Florida }
Escambia County

STATE OF FLORIDA
DOCUMENTARY STAMP TAX
DEPT. OF REVENUE
JUN 11 1984
11151
416.25

Before the subscriber personally appeared WILLIAM E. COKER, JR., and ANITA MASON COKER, husband and wife, known to me, and known to me to be the individuals described by said names in and who executed the foregoing instrument and acknowledged that they executed the same for the uses and purposes therein set forth.

Given under my hand and official seal this 11th day of June, 1984

This instrument was prepared by:
MICHAEL D. SMITH, ESQUIRE
Hartell, Wiltshire, Stone & Swearingen
201 East Government Street
Address Pensacola, Florida 32501

Mary Janet Bradley
My commission expires 12/21/84

PHANN06112010113155A

Prepared By/Return To:

United Bank

P O Box 8

Atmore, AL 36504

DOCUMENTARY STAMP TAX IN THE AMOUNT
OF \$ _____ AND INTANGIBLE TAX IN
THE AMOUNT OF \$ _____ ARE BEING
PAID UPON THE RECORDATION HEREOF.

(Reserved for Recording Office)

This is a balloon mortgage and the final principal payment or the principal balance due upon maturity is \$116,733.83, together with accrued interest, if any, and all advancements made by the mortgagee under the terms of this mortgage.

MORTGAGE AND SECURITY AGREEMENT

Mortgagor (last name first):

Mortgagee:

DILLER KELVIN E. AND DILLER CONSTANCE S a.k.a DILLER
CONSTANCE B., Husband and Wife

United Bank

4970 HIGHWAY 97
Mailing Address

P O Box 8
Mailing Address

WALNUT HILL FL 32568
City State Zip

Atmore AL 36504
City State Zip

STATE OF Florida

COUNTY OF Escambia

THIS MORTGAGE AND SECURITY AGREEMENT (herein referred to as the "Mortgage") is made and entered into this day by and between Mortgagor and Mortgagee.

KNOWN ALL MEN BY THESE PRESENTS: THAT

WHEREAS, Borrower has requested an extension of credit from Mortgagee; and

WHEREAS, Mortgagee is prepared to extend credit conditioned upon the provision of adequate collateral; and

WHEREAS, Mortgagor is prepared to pledge certain real and/or personal property as security for Mortgagee's extension of credit to Borrower in consideration for that extension of credit; and

WHEREAS, pursuant to the foregoing recitations, Borrower has or may become indebted to Mortgagee in the principal sum of One Hundred Nineteen Thousand Two Hundred Seventy and 18/100 Dollars (\$ 119,270.18) evidenced by ONE promissory note or agreement of even date herewith in favor of Mortgagee, said promissory note to mature on February 01, 2013.

WHEREAS, Mortgagor desires to secure prompt payment by Borrower of (a) the indebtedness described above, together with interest and charges, according to the terms of said promissory note or agreement and any extensions, modifications or renewals thereof, (b) any additional and future advances with interest thereon that Mortgagee may make to Borrower as provided in Paragraph 2, (c) any advances with interest that Mortgagee may make to protect the property herein conveyed as provided in Paragraph 3, 4, 5 and 6, and (e) any advance with interest that Mortgagee may make for attorneys' fees and other expenses as provided in Paragraph 17 (all being referred to herein as the "Indebtedness").

NOW THEREFORE, in consideration of the Indebtedness,

KELVIN E. DILLER AND CONSTANCE S. DILLER

does hereby grant, bargain, sell and convey unto Mortgagee all of Mortgagor's right, title, and interest in and to and the real property described below situated in the County of Escambia, State of Florida:

SEE ATTACHED EXHIBIT A

Rachel Holland
Witness
Vickie Day
Witness

Mortgagor:

Kelvin E. Diller MAY 11 2010
KELVIN E. DILLER Date

Constance S. Diller a.k.a. Constance R. Diller MAY 11 2010
CONSTANCE S. DILLER a.k.a. CONSTANCE R. DILLER Date

Date

Date

Date

Date

Attest

FOR AN INDIVIDUAL ACTING IN HIS OWN RIGHT:

STATE OF Alabama

COUNTY OF Escambia

The foregoing instrument was acknowledged before me this 11th day of May, 2010, by Kelvin E. Diller and Constance S. Diller aka Constance R. Diller (name of person acknowledging), who is personally known to me or who has produced _____ (type of identification) as identification.

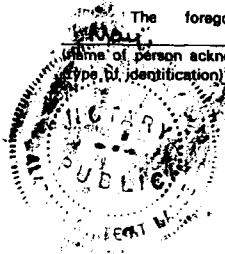

Vickie Day
Print Name: Vickie Day
Notary Public
Commission Number, if any: Dec. 17, 2011
Expires

FOR AN INDIVIDUAL ACTING IN HIS OWN RIGHT:

STATE OF _____

COUNTY OF _____

The foregoing instrument was acknowledged before me this _____ day of _____, _____, by _____ (name of person acknowledging), who is personally known to me or who has produced _____ (type of identification) as identification.

Print Name: _____
Notary Public
Commission Number, if any: _____

PHANN05112010113628A

EXHIBIT A

RECORDED AS RECEIVED

Parcel #1:

Begin at the SW corner of Section 37, Township 4 North, Range 32 West, Escambia County, Florida; thence N00°32'11"W along the West line of said Section for 2626.71 feet to the NW corner of the SW 1/4 of said Section; thence N89°28'26"E along the North line of said SW 1/4 for 1626.94 feet to the Westerly R/W line of State Road No. 97 (100' R/W); thence Southeasterly along said Westerly R/W line and along the arc of a curve concave to the NE having a radius of 1786.68 feet and a delta angle of 1°12'18" (chord bearing of S27°17'48"E, chord distance of 37.57 feet) for an arc distance of 37.57 feet to the P.T. of said curve; thence S27°53'57"E along said Westerly R/W line for 1229.24 feet; thence S89°28'26"W for 719.10 feet; thence S0°33'30"E for 1514.12 feet to the South line of said Section; thence N89°58'19"W along the South line of said Section for 1499.66 feet to the P.O.B. Containing 181.08 Acres, more or less.

Parcel #2:

Lots 1, 2, 3, 4, 5, 6, 7, 8, 9, 10, 11, 12, 13, 14, 15, 16, 17, and 18, of Tuna Oil Products Corporation's Subdivision of the East 1/2 of the West 1/2 of the Joel A. McDavid Donation, in Section 39, Township 4 North, Range 32 West, according to plat of said subdivision recorded in Plat Book 1 at Page 45 of the public records of said Escambia County, Florida.

LESS AND EXCEPT official Record Book 63 at page 148, County Road Right-of-Way.

✓ 1/4 of NW 1/4 of SE 1/4 and 1/4 of NE 1/4 of SE 1/4 of Section 39, Township 4 North, Range 32 West, LESS road right-of-way.

Said lands containing 40 acres, more or less, in Escambia County, Florida, are subject to any valid and existing mineral right and royalty transfer and mineral deed, or any valid reservation of oil, gas, and minerals underlying said lands included in any conveyance heretofore duly recorded in the Public Records of said county.

In addition thereto, the following described fixtures shall be deemed to be a part of the realty and are a portion of the security for the indebtedness herein mentioned: (5)-3,200 Bu metal grain storage bins; (1)-1,000 Bu metal load out bin; (1)-1,500 Bu metal holding tank; (1)-600 Bu metal grain holding tank; (1)-3,000 Bu/hr bucket grain elevator leg.

Signed for Identification:

Kelvin E. Diller MAY 11 2010 _____ Date

KELVIN E. DILLER MAY Date: 2010 _____ Date

Constance S. Diller aka _____ Date

CONSTANCE S. DILLER s.k.a. MAY Date: 2010 _____ Date

Constance R. Diller _____ Date

CONSTANCE R. DILLER Date _____ Date

DR BK 5022 P60960
Escambia County, Florida
INSTRUMENT 2002-033839

MTS DOC STAMPS PD @ ESC CO \$2275.00
12/03/02 ERNIE LEE MORGAN, CLERK
By: *Jeff Russell*

INTANGIBLE TAX PD @ ESC CO \$1300.00
12/03/02 ERNIE LEE MORGAN, CLERK
By: *Jeff Russell*

WHEN RECORDED MAIL TO:

UAP/Ga. Ag. Chem., Inc.
121 N. Westover Blvd.
Albany, GA 31707

This Mortgage prepared by:

Name:
Company:
Address:

**MORTGAGE
FUTURE ADVANCES**

NOTICE: This Mortgage secures all future advances from Lender to Grantor; however, in no event will the principal amount secured at any one time exceed \$ 650,000.

THIS MORTGAGE IS DATED 8/13/02, between Kelvin E. Diller and Constance E. Diller, whose address is 4870 Highway 97, Walnut Hill, FL 32568 (referred to below as "Grantor"); and UAP/Ga. Ag. Chem., Inc., whose address is 121 N. Westover Blvd., Albany, GA 31707 (referred to below as "Lender").

GRANT OF MORTGAGE. For valuable consideration, Grantor mortgages to Lender all of Grantor's right, title, and interest in and to the following described real property, together with all existing or subsequently erected or affixed buildings, improvements and fixtures; all easements, rights of way, and appurtenances; all water, water rights, watercourses and ditch rights (including stock in utilities with ditch or irrigation rights); and all other rights, royalties, and profits relating to the real property, including without limitation all minerals, oil, gas, geothermal and similar matters, located in Escambia County, State of Florida (the "Real Property"):

see exhibit "A":

Grantor presently assigns to Lender all of Grantor's right, title, and interest in and to all leases of the Property and all Rents from the Property. In addition, Grantor grants to Lender a Uniform Commercial Code security interest in the Personal Property and Rents.

DEFINITIONS. The following words shall have the following meanings when used in this Mortgage. Terms not otherwise defined in this Mortgage shall have the meanings attributed to such terms in the Uniform Commercial Code. All references to dollar amounts shall mean amounts in lawful money of the United States of America.

Grantor. The word "Grantor" means Kelvin E. Diller and Constance E. Diller. The Grantor is the mortgagor under this Mortgage.

Guarantor. The word "Guarantor" means and includes without limitation each and all of the guarantors, sureties, and accommodation parties in connection with the indebtedness.

Improvements. The word "improvements" means and includes without limitation all existing and future improvements, buildings, structures, mobile homes affixed on the Real Property, facilities, additions, replacements and other construction on the Real Property.

Indebtedness. The word "indebtedness" means all principal and interest payable under the Note and any amounts expended or advanced by Lender to discharge obligations of Grantor or expenses incurred by Lender to enforce obligations of Grantor under this Mortgage, together with interest on such amounts as provided in this Mortgage. In addition to the Note, the word "indebtedness" includes all obligations, debts and liabilities, plus interest thereon, of Grantor to Lender, or any one or more of them, as well as all claims by Lender against Grantor, or any one or more of them, whether now existing or hereafter arising, whether related or unrelated to the purpose of the Note, whether voluntary or otherwise, whether due or not due, absolute or contingent, liquidated or unliquidated and whether Grantor may be liable individually or jointly with others, whether obligated as guarantor or otherwise, and whether recovery upon such indebtedness may be or hereafter may become barred by any statute of limitations, and whether such indebtedness may be or hereafter may become otherwise unenforceable. Specifically, without limitation, this Mortgage secures a revolving line of credit under which, upon request by Grantor, Lender at Lender's option, within twenty (20) years from the date of this Mortgage, may make future advances to Grantor. Such future advances, together with interest thereon, are secured by this Mortgage. At no time shall the principal amount of the indebtedness, not including sums advanced in accordance with this Mortgage to protect the security of the lien of this Mortgage, exceed the maximum sum of \$800,000.00.

Lender. The word "Lender" means UAP/Ga. Ag. Chem., Inc., its successors and assigns. The Lender is the mortgagee under this Mortgage.

Mortgage. The word "Mortgage" means this Mortgage between Grantor and Lender, and includes without limitation all assignments and security interest provisions relating to the Personal Property and Rents.

Note. The word "Note" means the promissory note or credit agreement dated 6-13-2002, in the original principal amount of \$500,000.00 from Grantor to Lender, together with all renewals of, extensions of, modifications of, refinancings of, consolidations of, and substitutions for the promissory note or agreement. The final maturity date of the obligation secured by this Mortgage is January 20, 2003.

**MORTGAGE
(Continued)**

Loan No 7001181-02

Severability. If a court of competent jurisdiction finds any provision of this Mortgage to be invalid or unenforceable as to any person or circumstance, such finding shall not render that provision invalid or unenforceable as to any other persons or circumstances. If feasible, any such offending provision shall be deemed to be modified to be within the limits of enforceability or validity; however, if the offending provision cannot be so modified, it shall be stricken and all other provisions of this Mortgage in all other respects shall remain valid and enforceable.

Successors and Assigns. Subject to the limitations stated in this Mortgage on transfer of Grantor's interest, this Mortgage shall be binding upon and inure to the benefit of the parties, their successors and assigns. If ownership of the Property becomes vested in a person other than Grantor, Lender, without notice to Grantor, may deal with Grantor's successors with reference to this Mortgage and the indebtedness by way of forbearance or extension without releasing Grantor from the obligations of this Mortgage or liability under the indebtedness.

Time is of the Essence. Time is of the essence in the performance of this Mortgage.

Waivers and Consents. Lender shall not be deemed to have waived any rights under this Mortgage (or under the Related Documents) unless such waiver is in writing and signed by Lender. No delay or omission on the part of Lender in exercising any right shall operate as a waiver of such right or any other right. A waiver by any party of a provision of this Mortgage shall not constitute a waiver of or prejudice the party's right otherwise to demand strict compliance with that provision or any other provision. No prior waiver by Lender, nor any course of dealing between Lender and Grantor, shall constitute a waiver of any of Lender's rights or any of Grantor's obligations as to any future transactions. Whenever consent by Lender is required in this Mortgage, the granting of such consent by Lender in any instance shall not constitute continuing consent to subsequent instances where such consent is required.

EACH GRANTOR ACKNOWLEDGES HAVING READ ALL THE PROVISIONS OF THIS MORTGAGE, AND EACH GRANTOR AGREES TO ITS TERMS.

WITNESSES:

x Chris Dine
x Steve Gmelison

IN WITNESS WHEREOF, THIS MORTGAGE HAS BEEN SIGNED AND SEALED BY THE UNDERSIGNED, WHO ACKNOWLEDGES A COMPLETED COPY HEREOF.

GRANTOR:

x [Signature] (SEAL)
Kelvin E. Diller
x [Signature] (SEAL)
Constance E. Diller

INDIVIDUAL ACKNOWLEDGMENT

STATE OF Alabama)
COUNTY OF Escambia) ss

The foregoing instrument was acknowledged before me this 13 day of August, 2002 by Kelvin E. Diller and Constance E. Diller, who is personally known to me or who has produced identification and who did / did not take an oath.

Darlene G. Lassitter
(Signature of Person Taking Acknowledgment)
Darlene G. Lassitter
(Name of Acknowledger Typed, Printed or Stamped)

(Title or Rank)

(Serial Number, if any)

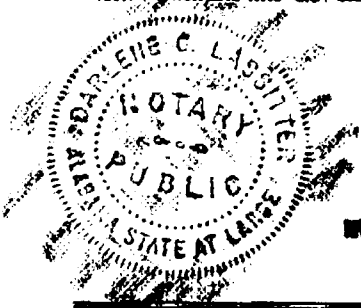

MY COMMISSION EXPIRES AUG. 5, 2003

EXHIBIT "A"

DILLER, KELVIN E. AND CONSTANCE R.

RCD Dec 03, 2002 03:06 pm
Escambia County, Florida

LEGAL DESCRIPTIONS

ERNIE LEE MAGAHA
Clerk of the Circuit Court
INSTRUMENT 2002-033839

Parcel #1:

7-2
PK

Begin at the SW corner of Section 37, Township 4 North, Range 32 West, Escambia County, Florida; thence N00°32'11"W along the West line of said Section for 2624.71 feet to the NW corner of the SW 1/4 of said Section; thence N89°28'26"E along the North line of said SW 1/4 for 1526.94 feet to the Westerly R/W line of State Road No. 97 (100' R/W); thence Southeasterly along said Westerly R/W line and along the arc of a curve concave to the NE having a radius of 1786.40 feet and a delta angle of 1°12'18" (chord bearing of S27°17'48"E, chord distance of 37.57 feet) for an arc distance of 37.57 feet to the P.T. of said curve; thence S27°53'57"E along said Westerly R/W line for 1229.24 feet; thence S89°28'26"W for 719.10 feet; thence S0°33'30"E for 1514.12 feet to the South line of said Section; thence N89°58'19"W along the South line of said Section for 1489.64 feet to the P.O.B. Containing 101.08 acres, more or less.

Parcel #2:

Lots 1, 2, 3, 4, 5, 6, 7, 8, 9, 10, 11, 12, 13, 14, 15, 16, 17, and 18, of Tung Oil Products Corporation's Subdivision of the East 1/2 of the West 1/2 of the Joel A. McDavid Donation, in Section 39, Township 4 North, Range 32 West, according to plat of said subdivision recorded in Plat Book 1 at Page 45 of the public records of said Escambia County, Florida.

LESS AND EXCEPT official Record Book 63 at page 148, County Road Right-of-Way.

✓
N½ of NW¼ of SE¼ and N½ of NE¼ of SE¼ of Section 39, Township 4 North, Range 32 West, LESS road right-of-way.

Said lands containing 40 acres, more or less, in Escambia County, Florida, are subject to any valid and existing mineral right and royalty transfer and mineral deed, or any valid reservation of oil, gas, and minerals underlying said lands included in any conveyance heretofore duly recorded in the Public Records of said county.

In addition thereto, the following described fixtures shall be deemed to be a part of the realty and are a portion of the security for the indebtedness herein mentioned: (5)-3,200 Bu metal grain storage bins; (1)-1,000 Bu metal load out bin; (1)-1,500 Bu metal holding tank; (1)-600 Bu metal grain holding tank; (1)-3,000 Bu/Hr bucket grain elevator leg.

This instrument was prepared by THE FIRST NATIONAL BANK & TRUST
P.O. BOX 27, ATMORE, ALABAMA 36504 (address)

STATE OF FLORIDA'S DOCUMENTARY STAMP TAX REQUIRED BY LAW
HAS BEEN PAID TO THE CLERK OF THE CIRCUIT COURT FOR THE
COUNTY OF ESCAMBIA, STATE OF FLORIDA

FLORIDA
State of ~~ALABAMA~~ Space Above This Line For Recording Data

MORTGAGE
(With Future Advance Clause)

1. **DATE AND PARTIES.** The date of this Mortgage (Security Instrument) is 10/11/06 and the parties, their addresses and tax identification numbers, if required, are as follows:

MORTGAGOR: KELVIN DILLER AND CONNIE DILLER
4870 HIGHWAY 97
WALNUT HILL, FL 32568-2014

If checked, refer to the attached Addendum incorporated herein, for additional Mortgagors, their signatures and acknowledgments.

LENDER: THE FIRST NATIONAL BANK OF ATMORE
ORGANIZED AND EXISTING UNDER THE LAWS OF THE UNITED STATES OF AMERICA
POST OFFICE BOX 27
ATMORE, AL 36504

2. **CONVEYANCE.** For good and valuable consideration, the receipt and sufficiency of which is acknowledged, and to secure the Secured Debt (defined below) and Mortgagor's performance under this Security Instrument, Mortgagor grants, bargains, conveys, sells and mortgages to Lender, with power of sale, the following described property:
REAL ESTATE LOCATED IN ESCAMBIA COUNTY, FLORIDA, AS DESCRIBED ON ENCLOSED FLORIDA MORTGAGES DATED 5/13/02 AND 4/25/02 AND RECORDED IN THE OFFICE OF THE RECORDING CLERK OF ESCAMBIA COUNTY, FLORIDA AND UCC FILED WITH OFFICE OF RECORDING CLERK OF ESCAMBIA COUNTY, FLORIDA, COVERING ALL EQUIPMENT NOW OWNED OR HEREAFTER ACQUIRED

The property is located in ESCAMBIA (County) at 4870 HIGHWAY 97 (Address), WALNUT HILL (City), FLORIDA 32568 (ZIP Code)

Together with all rights, easements, appurtenances, royalties, mineral rights, oil and gas rights, all water and riparian rights, ditches, and water stock and all existing and future improvements, structures, fixtures, and replacements that may now, or at any time in the future, be part of the real estate described above (all referred to as "Property"). When the Secured Debt (hereafter defined) is paid in full and all underlying agreements have been terminated, this Mortgage will become null and void.

3. **MAXIMUM OBLIGATION LIMIT.** The total principal amount secured by this Security Instrument at any one time shall not exceed \$ 62,775.30. This limitation of amount does not include interest and other fees and charges validly made pursuant to this Security Instrument. Also, this limitation does not apply to advances made under the terms of this Security Instrument to protect Lender's security and to perform any of the covenants contained in this Security Instrument.

4. **SECURED DEBT AND FUTURE ADVANCES.** The term "Secured Debt" is defined as follows:
A. Debt incurred under the terms of all promissory note(s), contract(s), guaranty(ies) or other evidence of debt described below and all their extensions, renewals, modifications or substitutions. (When referencing the debts below it is suggested that you include items such as borrowers' names, note amounts, interest rates, maturity dates, etc.)

LOAN #9040767 IN THE AMOUNT OF \$62,775.30 WITH A MATURITY DATE OF 11/20/2012 INCLUDING ALL EXTENSIONS, RENEWALS, OR MODIFICATIONS UNDER THE SAME OR A DIFFERENT NUMBER

page 1 of 1
KLO OCB

- B. All future advances from Lender to Mortgagor or other future obligations of Mortgagor to Lender under any promissory note, contract, guaranty, or other evidence of debt executed by Mortgagor in favor of Lender after this Security Instrument whether or not this Security Instrument is specifically referenced. If more than one person signs this Security Instrument, each Mortgagor agrees that this Security Instrument will secure all future advances and future obligations that are given to or incurred by any one or more Mortgagor, or any one or more Mortgagor and others. All future advances and other future obligations are secured by this Security Instrument even though all or part may not yet be advanced. All future advances and other future obligations are secured as if made on the date of this Security Instrument. Nothing in this Security Instrument shall constitute a commitment to make additional or future loans or advances in any amount. Any such commitment must be agreed to in a separate writing.
- C. All obligations Mortgagor owes to Lender, which may later arise, to the extent not prohibited by law, including, but not limited to, liabilities for overdrafts relating to any deposit account agreement between Mortgagor and Lender.
- D. All additional sums advanced and expenses incurred by Lender for insuring, preserving or otherwise protecting the Property and its value and any other sums advanced and expenses incurred by Lender under the terms of this Security Instrument.
- This Security Instrument will not secure any other debt if Lender fails to give any required notice of the right of rescission.
5. **PAYMENTS.** Mortgagor agrees that all payments under the Secured Debt will be paid when due and in accordance with the terms of the Secured Debt and this Security Instrument.
 6. **WARRANTY OF TITLE.** Mortgagor warrants that Mortgagor is or will be lawfully seized of the estate conveyed by this Security Instrument and has the right to grant, bargain, convey, sell, and mortgage, with the power of sale, the Property. Mortgagor also warrants that the Property is unencumbered, except for encumbrances of record.
 7. **PRIOR SECURITY INTERESTS.** With regard to any other mortgage, deed of trust, security agreement or other lien document that created a prior security interest or encumbrance on the Property, Mortgagor agrees:
 - A. To make all payments when due and to perform or comply with all covenants.
 - B. To promptly deliver to Lender any notices that Mortgagor receives from the holder.
 - C. Not to allow any modification or extension of, nor to request any future advances under any note or agreement secured by the lien document without Lender's prior written consent.
 8. **CLAIMS AGAINST TITLE.** Mortgagor will pay all taxes, assessments, liens, encumbrances, lease payments, ground rents, utilities, and other charges relating to the Property when due. Lender may require Mortgagor to provide to Lender copies of all notices that such amounts are due and the receipts evidencing Mortgagor's payment. Mortgagor will defend title to the Property against any claims that would impair the lien of this Security Instrument. Mortgagor agrees to assign to Lender, as requested by Lender, any rights, claims or defenses Mortgagor may have against parties who supply labor or materials to maintain or improve the Property.
 9. **DUE ON SALE OR ENCUMBRANCE.** Lender may, at its option, declare the entire balance of the Secured Debt to be immediately due and payable upon the creation of, or contract for the creation of, any lien, encumbrance, transfer or sale of the Property. This right is subject to the restrictions imposed by federal law (12 C.F.R. 591), as applicable. This covenant shall run with the Property and shall remain in effect until the Secured Debt is paid in full and this Security Instrument is released.
 10. **PROPERTY CONDITION, ALTERATIONS AND INSPECTION.** Mortgagor will keep the Property in good condition and make all repairs that are reasonably necessary. Mortgagor shall not commit or allow any waste, impairment, or deterioration of the Property. Mortgagor will keep the Property free of noxious weeds and grasses. Mortgagor agrees that the nature of the occupancy and use will not substantially change without Lender's prior written consent. Mortgagor will not permit any change in any license, restrictive covenant or easement without Lender's prior written consent. Mortgagor will notify Lender of all demands, proceedings, claims and actions against Mortgagor, and of any loss or damage to the Property. Lender or Lender's agents may, at Lender's option, enter the Property at any reasonable time for the purpose of inspecting the Property. Lender shall give Mortgagor notice at the time of or before an inspection specifying a reasonable purpose for the inspection. Any inspection of the Property shall be entirely for Lender's benefit and Mortgagor will in no way rely on Lender's inspection.
 11. **AUTHORITY TO PERFORM.** If Mortgagor fails to perform any duty or any of the covenants contained in this Security Instrument, Lender may, without notice, perform or cause them to be performed. Mortgagor appoints Lender as attorney in fact to sign Mortgagor's name or pay any amount necessary for performance. Lender's right to perform for Mortgagor shall not create an obligation to perform, and Lender's failure to perform will not preclude Lender from exercising any of Lender's other rights under the law or this Security Instrument. If any construction on the Property is discontinued or not carried on in a reasonable manner, Lender may take all steps necessary to protect Lender's security interest in the Property, including completion of the construction.
 12. **ASSIGNMENT OF LEASES AND RENTS.** Mortgagor absolutely, unconditionally, irrevocably and immediately assigns, grants, bargains, conveys and mortgages to Lender all the right, title and interest in the following (all referred to as Property): existing or future leases, subleases, licenses, guaranties and any other written or verbal agreements for the use and occupancy of the Property, including any extensions, renewals, modifications or replacements (all referred to as Leases); and rents, issues and profits (all referred to as Rents). In the event any item listed as Leases or Rents is determined to be personal property, this Assignment will also be regarded as a security agreement. Mortgagor will promptly provide Lender with copies of the Leases and will certify these Leases are true and correct copies. The existing Leases will be provided on execution of the Assignment, and all future Leases and any other information with respect to these Leases will be provided immediately after they are executed. Lender grants Mortgagor a revocable license to collect, receive, enjoy and use the Rents as long as Mortgagor is not in default. Mortgagor's default automatically and immediately revokes this license. Upon default, Mortgagor will receive any Rents in trust for Lender and Mortgagor will not commingle the Rents with any other funds. When Lender so directs, Mortgagor will endorse and deliver any payments of Rents from the Property to Lender. Mortgagor agrees that Lender will not be considered to be a mortgagee-in-possession by executing this Security Instrument or by collecting or receiving payments on the Secured Debts, but only may become a mortgagee-in-possession after Mortgagor's license to collect, receive, enjoy and use the Rents is revoked by Lender or automatically revoked on Mortgagor's default, and Lender takes actual possession of the Property. Consequently, until Lender takes actual possession of the Property, Lender is not obligated to perform or discharge any obligation of Mortgagor under the Leases, appear in or defend any action or proceeding relating to the Rents, the Leases or the Property, or be liable in any way for any injury or damage to any person or property sustained in or about the Property. Mortgagor agrees that this Security Instrument is immediately effective between Mortgagor and Lender and effective as to third parties on the recording of this Assignment. As long as this Assignment is in effect, Mortgagor warrants and represents that no default exists under the Leases, and the parties subject to the Leases have not violated any applicable law on leases, licenses and landlords and tenants. This assignment is enforceable when Lender takes an affirmative action as prescribed by the law of the state where the Property is located. This Security Instrument will remain effective during any statutory redemption period until the Secured Debts are satisfied.
 13. **LEASEHOLDS; CONDOMINIUMS; PLANNED UNIT DEVELOPMENTS.** Mortgagor agrees to comply with the provisions of any lease if this Security Instrument is on a leasehold. If the Property includes a unit in a condominium, time-share or a planned unit development, Mortgagor will perform all of Mortgagor's duties under the covenants, by-laws, or regulations of the condominium or planned unit development.

14. **DEFAULT.** Mortgagor will be in default if any party obligated on the Secured Debt fails to make payment when due. Mortgagor will be in default if a breach occurs under the terms of this Security Instrument or any other document executed for the purpose of creating, securing or guarantying the Secured Debt. A good faith belief by Lender that Lender at any time is insecure with respect to any person or entity obligated on the Secured Debt or that the prospect of any payment or the value of the Property is impaired shall also constitute an event of default.

15. **REMEDIES ON DEFAULT.** In some instances, federal and state law will require Lender to provide Mortgagor with notice of the right to cure or other notices and may establish time schedules for foreclosure actions. Subject to these limitations, if any, Lender may accelerate the Secured Debt and foreclose this Security Instrument in a manner provided by law if Mortgagor is in default.

At the option of Lender, all or any part of the agreed fees and charges, accrued interest and principal shall become immediately due and payable, after giving notice if required by law, upon the occurrence of a default or anytime thereafter. In addition, Lender shall be entitled to all the remedies provided by law, including without limitation, the power to sell the Property, the terms of the Secured Debt, this Security Instrument and any related documents. All remedies are distinct, cumulative and not exclusive, and the Lender is entitled to all remedies provided at law or equity, whether or not expressly set forth. The acceptance by Lender of any sum in payment or partial payment on the Secured Debt after the balance is due or is accelerated or after foreclosure proceedings are filed shall not constitute a waiver of Lender's right to require complete cure of any existing default. By not exercising any remedy on Mortgagor's default, Lender does not waive Lender's right to later consider the event a default if it continues or happens again.

If Lender initiates a judicial foreclosure, Lender shall give the notices as required by applicable law. If Lender invokes the power of sale, Lender shall publish the notice of sale, and arrange to sell all or part of the Property, as required by applicable law. Lender or its designee may purchase the Property at any sale. Lender shall apply the proceeds of the sale in the manner required by applicable law. The sale of any part of the Property shall only operate as a foreclosure of the sold Property, so any remaining Property shall continue to secure any unsatisfied Secured Debt and Lender may further foreclose under the power of sale or by judicial foreclosure.

If Lender invokes the power of sale, Lender will place in the United States mail a copy of the notice of sale to Mortgagor that Lender will cause to be published once a week for three consecutive weeks in a newspaper published in the county where the Property is located. Then, Lender will sell the Property to the highest bidder at public auction at the front door of the courthouse in the county where the Property is located. Lender will deliver to the purchaser Lender's deed conveying the Property. Lender may opt to sell the Property in parcels or as a whole. Lender or its designee may purchase the Property at any sale. Mortgagor covenants and agrees that the proceeds of the sale will be applied in the following order: (a) to the expense of advertising, selling and conveying, including a reasonable attorney's fee; (b) the payment of any amounts that may have been expended, or that may then be necessary to expend, in paying insurance, taxes, or other encumbrances, with interest thereon; (c) to all sums secured by this Security Instrument; and (d) any excess to the person or persons legally entitled to it.

16. **EXPENSES; ADVANCES ON COVENANTS; ATTORNEYS' FEES; COLLECTION COSTS.** Except when prohibited by law, Mortgagor agrees to pay all of Lender's expenses if Mortgagor breaches any covenant in this Security Instrument. Mortgagor will also pay on demand any amount incurred by Lender for insuring, inspecting, preserving or otherwise protecting the Property and Lender's security interest. These expenses will bear interest from the date of the payment until paid in full at the highest interest rate in effect as provided in the terms of the Secured Debt. Mortgagor agrees to pay all costs and expenses incurred by Lender in collecting, enforcing or protecting Lender's rights and remedies under this Security Instrument. This amount may include, but is not limited to, attorneys' fees, court costs, and other legal expenses. If the Secured Debt is subject to the Alabama Mini-Code, then reasonable attorneys' fees after default are available only when: the original amount financed exceeds \$300, the attorney is not the Lender's salaried employee, and the amount due does not exceed 15% of the unpaid debt after default. No attorneys' fees after default are available when the Secured Debt is an open-end credit plan and its unpaid balance is \$300 or less. This Security Instrument shall remain in effect until released. Mortgagor agrees to pay for any recordation costs of such release.

17. **ENVIRONMENTAL LAWS AND HAZARDOUS SUBSTANCES.** As used in this section, (1) Environmental Law means, without limitation, the Comprehensive Environmental Response, Compensation and Liability Act (CERCLA, 42 U.S.C. 9601 et seq.), and all other federal, state and local laws, regulations, ordinances, court orders, attorney general opinions or interpretive letters concerning the public health, safety, welfare, environment or a hazardous substance; and (2) Hazardous Substance means any toxic, radioactive or hazardous material, waste, pollutant or contaminant which has characteristics which render the substance dangerous or potentially dangerous to the public health, safety, welfare or environment. The term includes, without limitation, any substances defined as "hazardous material," "toxic substances," "hazardous waste" or "hazardous substance" under any Environmental Law.

Mortgagor represents, warrants and agrees that:

- A. Except as previously disclosed and acknowledged in writing to Lender, no Hazardous Substance is or will be located, stored or released on or in the Property. This restriction does not apply to small quantities of Hazardous Substances that are generally recognized to be appropriate for the normal use and maintenance of the Property.
 - B. Except as previously disclosed and acknowledged in writing to Lender, Mortgagor and every tenant have been, are, and shall remain in full compliance with any applicable Environmental Law.
 - C. Mortgagor shall immediately notify Lender if a release or threatened release of a Hazardous Substance occurs on, under or about the Property or there is a violation of any Environmental Law concerning the Property. In such an event, Mortgagor shall take all necessary remedial action in accordance with any Environmental Law.
 - D. Mortgagor shall immediately notify Lender in writing as soon as Mortgagor has reason to believe there is any pending or threatened investigation, claim, or proceeding relating to the release or threatened release of any Hazardous Substance or the violation of any Environmental Law.
18. **CONDEMNATION.** Mortgagor will give Lender prompt notice of any pending or threatened action, by private or public entities to purchase or take any or all of the Property through condemnation, eminent domain, or any other means. Mortgagor authorizes Lender to intervene in Mortgagor's name in any of the above described actions or claims. Mortgagor assigns to Lender the proceeds of any award or claim for damages connected with a condemnation or other taking of all or any part of the Property. Such proceeds shall be considered payments and will be applied as provided in this Security Instrument. This assignment of proceeds is subject to the terms of any prior mortgage, deed of trust, security agreement or other lien document.
19. **INSURANCE.** Mortgagor shall keep Property insured against loss by fire, flood, theft and other hazards and risks reasonably associated with the Property due to its type and location. This insurance shall be maintained in the amounts and for the periods that Lender requires. What Lender requires pursuant to the preceding two sentences can change during the term of the Secured Debt. The insurance carrier providing the insurance shall be chosen by Mortgagor subject to Lender's approval, which shall not be unreasonably withheld. If Mortgagor fails to maintain the coverage described above, Lender may, at Lender's option, obtain coverage to protect Lender's rights in the Property according to the terms of this Security Instrument.

All insurance policies and renewals shall be acceptable to Lender and shall include a standard "mortgage clause" and, where applicable, "loss payee clause." Mortgagor shall immediately notify Lender of cancellation or termination of the insurance. Lender shall have the right to hold the policies and renewals. If Lender requires, Mortgagor shall immediately give to Lender all receipts of paid premiums and renewal notices. Upon loss, Mortgagor shall give immediate notice to the insurance carrier and Lender. Lender may make proof of loss if not made immediately by Mortgagor.

Unless otherwise agreed in writing, all insurance proceeds shall be applied to the restoration or repair of the Property or to the Secured Debt, whether or not then due, at Lender's option. Any application of proceeds to principal shall not extend or postpone the due date of the scheduled payment nor change the amount of any payment. Any excess will be paid to the Mortgagor. If the Property is acquired by Lender, Mortgagor's right to any insurance policies and proceeds resulting from damage to the Property before the acquisition shall pass to Lender to the extent of the Secured Debt existing immediately before the acquisition.

- 20. **ESCROW FOR TAXES AND INSURANCE.** Unless otherwise provided in a separate agreement, Mortgagor will not be required to pay to Lender funds for taxes and insurance in escrow.
- 21. **FINANCIAL REPORTS AND ADDITIONAL DOCUMENTS.** Mortgagor will provide to Lender upon request, any financial statement or information Lender may deem reasonably necessary. Mortgagor agrees to sign, deliver, and file any additional documents or certifications that Lender may consider necessary to perfect, continue, and preserve Mortgagor's obligations under this Security Instrument and Lender's lien status on the Property.
- 22. **JOINT AND INDIVIDUAL LIABILITY; CO-SIGNERS; SUCCESSORS AND ASSIGNS BOUND.** All duties under this Security Instrument are joint and individual. If Mortgagor signs this Security Instrument but does not sign an evidence of debt, Mortgagor does so only to mortgage Mortgagor's interest in the Property to secure payment of the Secured Debt and Mortgagor does not agree to be personally liable on the Secured Debt. If this Security Instrument secures a guaranty between Lender and Mortgagor, Mortgagor agrees to waive any rights that may prevent Lender from bringing any action or claim against Mortgagor or any party indebted under the obligation. These rights may include, but are not limited to, any anti-deficiency or one-action laws. Mortgagor agrees that Lender and any party to this Security Instrument may extend, modify or make any change in the terms of this Security Instrument or any evidence of debt without Mortgagor's consent. Such a change will not release Mortgagor from the terms of this Security Instrument. The duties and benefits of this Security Instrument shall bind and benefit the successors and assigns of Mortgagor and Lender.
- 23. **APPLICABLE LAW; SEVERABILITY; INTERPRETATION.** This Security Instrument is governed by the laws of the jurisdiction in which Lender is located, except to the extent otherwise required by the laws of the jurisdiction where the Property is located. This Security Instrument is complete and fully integrated. This Security Instrument may not be amended or modified by oral agreement. Any section in this Security Instrument, attachments, or any agreement related to the Secured Debt that conflicts with applicable law will not be effective, unless that law expressly or impliedly permits the variations by written agreement. If any section of this Security Instrument cannot be enforced according to its terms, that section will be severed and will not affect the enforceability of the remainder of this Security Instrument. Whenever used, the singular shall include the plural and the plural the singular. The captions and headings of the sections of this Security Instrument are for convenience only and are not to be used to interpret or define the terms of this Security Instrument. Time is of the essence in this Security Instrument.
- 24. **NOTICE.** Unless otherwise required by law, any notice shall be given by delivering it or by mailing it by first class mail to the appropriate party's address on page 1 of this Security Instrument, or to any other address designated in writing. Notice to one mortgagor will be deemed to be notice to all mortgagors.
- 25. **WAIVERS.** Except to the extent prohibited by law, Mortgagor waives all appraisal rights relating to the Property.
- 26. **OTHER TERMS.** If checked, the following are applicable to this Security Instrument:
 - Line of Credit.** The Secured Debt includes a revolving line of credit provision. Although the Secured Debt may be reduced to a zero balance, this Security Instrument will remain in effect until the Secured Debt and all underlying agreements have been terminated in writing by Lender.
 - Construction Loan.** This Security Instrument secures an obligation incurred for the construction of an improvement on the Property.
 - Fixture Filing.** Mortgagor grants to Lender a security interest in all goods that Mortgagor owns now or in the future and that are or will become fixtures related to the Property. This Security Instrument suffices as a financing statement and any carbon, photographic or other reproduction may be filed of record for purposes of Article 9 of the Uniform Commercial Code.
 - Riders.** The covenants and agreements of each of the riders checked below are incorporated into and supplement and amend the terms of this Security Instrument. [Check all applicable boxes]
 - Condominium Rider Planned Unit Development Rider Other
 - Additional Terms.**

SIGNATURES: By signing below, Mortgagor agrees to the terms and covenants contained in this Security Instrument and in any attachments. Mortgagor also acknowledges receipt of a copy of this Security Instrument on the date stated on page 1.

[Signature] @ 10/11/06 (Seal) *[Signature]* @ 10/11/06 (Seal)
(Signature) KELVIN DILLER (Date) (Signature) CONNIE DILLER (Date)

(Witness as to all signatures)

(Witness as to all signatures)

ACKNOWLEDGMENT:

STATE OF Al COUNTY OF Eschscholtz } ss.

I, a notary public, hereby certify that Kelvin Diller and Constance S. Diller whose name(s) is/are signed to the foregoing conveyance, and who is/are known to me, acknowledged before me on this day that, being informed of the contents of the conveyance, he/she/they executed the same voluntarily on the day the same bears date. Given under my hand this 11th day of October 2006.

My commission expires _____
(Seal)

MY COMMISSION EXPIRES FEB. 22, 2010

[Signature]
(Notary Public)

