

17-260

Tax Collector's Certification

CTY-513

Tax Deed Application Number

1700080

Date of Tax Deed Application

Mar 08, 2017

This is to certify that **BRISINGER FUND 1, LLC** **BRISINGER FUND 1, LLC**, holder of **Tax Sale Certificate Number 2014 / 4062**, Issued the 1st Day of June, 2014 and which encumbers the following described property in the county of Escambia County, State of Florida, to wit: **08-0419-500**

Cert Holder:
BRISINGER FUND 1, LLC
BRISINGER FUND 1, LLC
1338 S FOOTHILL DRIVE #129SALT LAKE CITY, UT
84108

Property Owner:
DESROCHERS DAVID
10 NIMITZ CT
PENSACOLA, FL 32507

LT 28 & 29 BLK 17 ALSO BEG AT NE COR OF LT 30 WLY 193
13/100 FT TO E R/W LI OF NIMITZ ST BEING P T OFull legal
attached.

has surrendered same in my office and made written application for tax deed in accordance with Florida Statutes. I certify that the following tax certificates, interest, ownership and encumbrance report fee, and Tax Collector's fees have been paid, or if the certificate is held by the County, all appropriate fees have been deposited.

Certificates owned by applicant and filed in connection with this application:

Certificate Year/Number	Account Number	Sale Date	Face Amount of Certificate	Interest	Total
2014/4062	08-0419-500	06/01/2014	1,479.82	73.99	1,553.81

Certificates redeemed by applicant or included (County) in connection with this tax deed application:

Certificate Year/Number	Account Number	Sale Date	Face Amount of Certificate	Tax Collector's Fee	Interest	Total
2016/3995	08-0419-500	06/01/2016	1,758.26	6.25	87.91	1,852.42
2015/4377	08-0419-500	06/01/2015	1,647.92	6.25	82.40	1,736.57

Amounts Certified by Tax Collector (Lines 1-7):

Total Amount Paid

1. Total of all Certificates in Applicant's Possession and Cost of the Certificates Redeemed by Applicant	5,142.80
2. Total of Delinquent Taxes Paid by Tax Deed Applicant	0.00
3. Total of Current Taxes Paid by Tax Deed Applicant	1647.05
4. Ownership and Encumbrance Report Fee	200.00
5. Tax Deed Application Fee	175.00
6. Total Interest Accrued by Tax Collector Pursuant to Section 197.542, F.S.	
7. Total (Lines 1 - 6)	7,164.85

Amounts Certified by Clerk of Court (Lines 8-15):

Total Amount Paid

8. Clerk of Court Statutory Fee for Processing Tax Deed	
9. Clerk of Court Certified Mail Charge	
10. Clerk of Court Advertising Charge	
11. Clerk of Court Recording Fee for Certificate of Notice	
12. Sheriff's Fee	
13. Interest Computed by Clerk of Court Pursuant to Section 197.542, F.S.	
14. Total (Lines 8 - 13)	
15. One-half Assessed Value of Homestead Property, if Applicable per F.S.	
16. Other Outstanding Certificates and Delinquent Taxes Not Included in this Application, If Applicable Per Florida Statutes	
17. Statutory (Opening) Bid; Total of Lines 7, 14, 15 (if applicable) and 16 (if applicable)	
18. Redemption Fee	6.25
19. Total Amount to Redeem	

Done this the 14th day of March, 2017 Scott Lunsford, Tax Collector of Escambia County

Date of Sale: **5 June 2017**

By *Shirley Rich, CFCA*
Senior Deputy Tax Collector

*This certification must be surrendered to the Clerk of the Circuit Court no later than ten (10) days after this date.

08-0419-500 2014

LT 28 & 29 BLK 17 ALSO BEG AT NE COR OF LT 30 WLY 193 13/100 FT TO E R/W LI OF NIMITZ ST BEING P T OF A CURVE HAVING A 25 FT RADIUS NELY & N ALG CURVE 29 72/100 FT TO NW COR OF LT 30 SELY 180 15/100 FT TO POB 2ND ADDN TO AERO VISTA PB 2 P 22 OR 6953 P 1208 SEC 50/51 T 2S R 30 CA 200

APPLICATION FOR TAX DEED

Section 197.502, Florida Statutes

512
R. 12/16

Application Number: 1700080

To: Tax Collector of ESCAMBIA COUNTY, Florida

I,
BRISINGER FUND 1, LLC
BRISINGER FUND 1, LLC
1338 S FOOTHILL DRIVE #129
SALT LAKE CITY, UT 84108,

hold the listed tax certificate and hereby surrender the same to the Tax Collector and make tax deed application thereon:

Account Number	Certificate No.	Date	Legal Description
08-0419-500	2014/4062	06-01-2014	LT 28 & 29 BLK 17 ALSO BEG AT NE COR OF LT 30 WLY 193 13/100 FT TO E RW LI OF NIMITZ ST BEING P T OF A CURVE HAVING A 25 FT RADIUS NELY & N ALG CURVE 29 72/100 FT TO NW COR OF LT 30 SELY 180 15/100 FT TO POB 2ND ADDN TO AERO VISTA PB 2 P 22 OR 6953 P 1208 SEC 50/51 T 2S R 30 CA 200

I agree to:

- pay any current taxes, if due and
- redeem all outstanding tax certificates plus interest not in my possession, and
- pay all delinquent and omitted taxes, plus interest covering the property.
- pay all Tax Collector's fees, ownership and encumbrance report costs, Clerk of the Court costs, charges and fees, and Sheriff's costs, if applicable.

Attached is the tax sale certificate on which this application is based and all other certificates of the same legal description which are in my possession.

Electronic signature on file
BRISINGER FUND 1, LLC
BRISINGER FUND 1, LLC
1338 S FOOTHILL DRIVE #129
SALT LAKE CITY, UT 84108

03-08-2017
Application Date

Applicant's signature



Chris Jones Escambia County Property Appraiser

- Real Estate Search
- Tangible Property Search
- Sale List
- Amendment 1/Portability Calculations

[Back](#)

← Navigate Mode Account Reference →

Printer Friendly Version

General Information		Assessments				
Reference:	502S305010280017	Year	Land	Imprv	Total	Cap Val
Account:	080419500	2016	\$27,550	\$76,870	\$104,420	\$104,420
Owners:	DESROCHERS DAVID	2015	\$27,550	\$73,027	\$100,577	\$99,275
Mail:	10 NIMITZ CT PENSACOLA, FL 32507	2014	\$27,550	\$69,436	\$96,986	\$90,250
Situs:	10 NIMITZ CT 32507	Disclaimer				
Use Code:	SINGLE FAMILY RESID	Amendment 1/Portability Calculations				
Taxing Authority:	COUNTY MSTU	★ File for New Homestead Exemption Online				
Tax Inquiry:	Open Tax Inquiry Window					
Tax Inquiry link courtesy of Scott Lunsford Escambia County Tax Collector						

Sales Data		2016 Certified Roll Exemptions		
Sale Date	Book Page	Value	Type	Official Records (New Window)
12/26/2012	6953 1208	\$55,000	WD	View Instr
08/15/2008	6366 264	\$84,200	WD	View Instr
Official Records Inquiry courtesy of Pam Childers Escambia County Clerk of the Circuit Court and Comptroller				
Legal Description				
LT 28 & 29 BLK 17 ALSO BEG AT NE COR OF LT 30 WLY 193 13/100 FT TO E R/W LI OF NIMITZ ST BEING P T OF A...				
Extra Features				
CARPORT METAL GARAGE PATIO				

Section Map Id:
CA200

Approx. Acreage:
0.5525

Zoned:
MDR

Evacuation & Flood Information
[Open Report](#)

View Florida Department of Environmental Protection (DEP) Data

[Launch Interactive Map](#)

Buildings
Address: 10 NIMITZ CT, Year Built: 1956, Effective Year: 1960
Structural Elements
DECOR/HILLWORK-AVERAGE
DWELLING UNITS-1
EXTERIOR WALL-BRICK-FACE/VENEER
FLOOR COVER-HARDWOOD/PARQUET
FOUNDATION-WOOD/SUB FLOOR

HEAT/AIR-CENTRAL H/AC
INTERIOR WALL-DRYWALL-PLASTER
NO. PLUMBING FIXTURES-6
NO. STORIES-1
ROOF COVER-DIMEN/ARCH SHNG
ROOF FRAMING-HIP
STORY HEIGHT-0
STRUCTURAL FRAME-WOOD FRAME

 Areas - 2187 Total SF
BASE AREA - 1675
GARAGE UNFIN - 308
OPEN PORCH FIN - 84
WOOD DECK FIN - 120

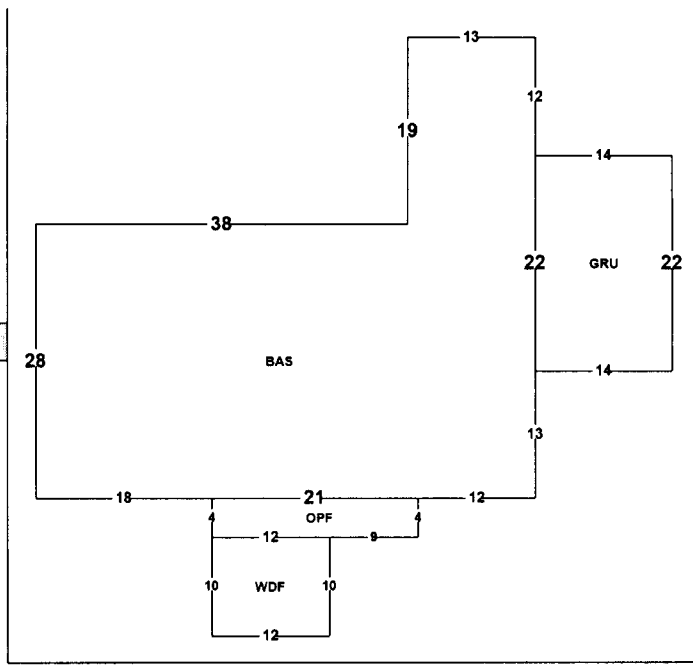

Images



3/7/13



3/7/13

The primary use of the assessment data is for the preparation of the current year tax roll. No responsibility or liability is assumed for inaccuracies or errors.

Last Updated: 03/21/2017 (tc.62395)

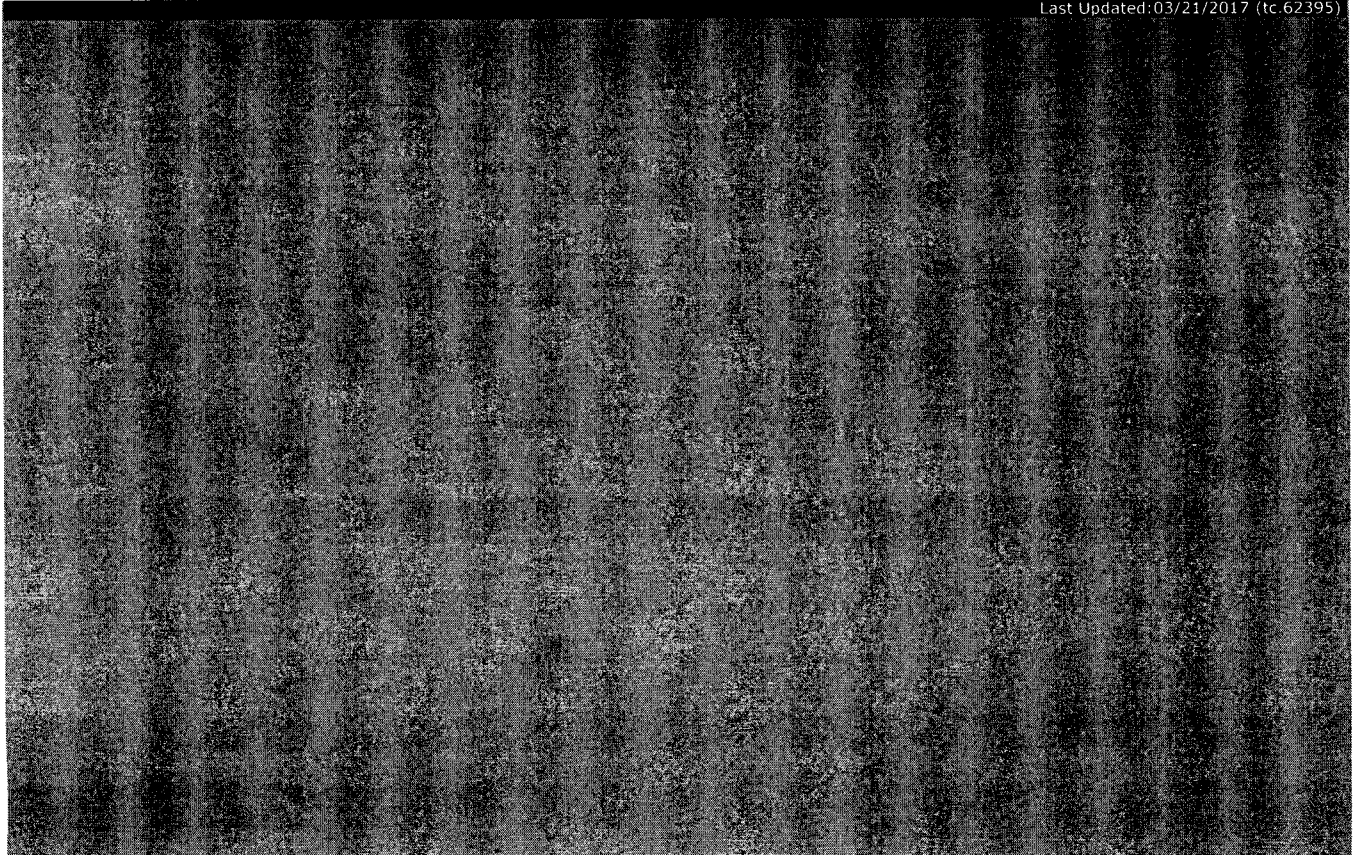

17-260

Southern Guaranty Title Company

4400 Bayou Boulevard, Suite 13B
Pensacola, Florida 32503
Telephone: 850-478-8121
Facsimile: 850-476-1437

OWNERSHIP AND ENCUMBRANCE REPORT

File No.: 13465

March 17, 2017

Escambia County Tax Collector
P.O. Box 1312
Pensacola, Florida 32591

Pursuant to your request, the Company has caused a search to be made of the Public Records of Escambia County, Florida, solely as revealed by records maintained from 03-17-1997, through 03-17-2017, and said search reveals the following:

1. THE GRANTEE(S) OF THE LAST DEED(S) OF RECORD IS:

David Desrochers

2. The land covered by this Report is:

LEGAL DESCRIPTION IS ATTACHED HERETO AND MADE A PART HEREOF

3. The following unsatisfied mortgages, liens and judgments affecting the land covered by this Report appear of record:

SEE CONTINUATION PAGE ATTACHED HERETO AND MADE A PART HEREOF

4. Taxes:

SEE CONTINUATION PAGE ATTACHED HERETO AND MADE A PART HEREOF

The foregoing report is prepared and furnished for information only, is not intended to constitute or imply any opinion, warranty, guaranty, insurance, or similar assurance as to the status of title, and no determination has been made of the authenticity of any instrument described or referred to herein. The name search for the purposes of determining applicable judgments and liens is limited to the apparent record owner(s) shown herein, No attempt has been made to determine whether the land is subject to liens or assessments which are not shown as existing liens by the public records. The Company's liability hereunder shall not exceed the cost of this Report, or \$1,000.00 whichever is less.

THIS REPORT SHALL NOT BE USED FOR THE ISSUANCE OF TITLE INSURANCE.

Southern Guaranty Title Company

By: 

March 17, 2017

**OWNERSHIP AND ENCUMBRANCE REPORT
LEGAL DESCRIPTION**

File No.: 13465

March 17, 2017

502S305010280017 - Full Legal Description

LT 28 & 29 BLK 17 ALSO BEG AT NE COR OF LT 30 WLY 193 13/100 FT TO E R/W LI OF NIMITZ ST BEING P T
OF A CURVE HAVING A 25 FT RADIUS NELY & N ALG CURVE 29 72/100 FT TO NW COR OF LT 30 SELY 180
15/100 FT TO POB 2ND ADDN TO AERO VISTA PB 2 P 22 OR 6953 P 1208 SEC 50/51 T 2S R 30 CA 200

**OWNERSHIP AND ENCUMBRANCE REPORT
CONTINUATION PAGE**

File No.: 13465

March 17, 2017

UNSATISFIED MORTGAGES, LIENS AND JUDGMENTS AFFECTING THE LAND COVERED BY THIS REPORT THAT APPEAR OF RECORD:

1. Taxes for the year 2013-2016 delinquent. The assessed value is \$104,420.00. Tax ID 08-0419-500.

PLEASE NOTE THE FOLLOWING:

- A. Subject to current year taxes.
- B. Taxes and assessments due now or in subsequent years.
- C. Subject to Easements, Restrictions and Covenants of record.
- D. Encroachments, overlaps, boundary line disputes, and any other matters which would be disclosed by an accurate survey and inspection of the premises.
- E. Oil, gas and mineral or any other subsurface rights of any kind or nature.

SOUTHERN GUARANTY TITLE COMPANY

4400 BAYOU BLVD., SUITE 13-B, CORDOVA SQUARE

PENSACOLA, FLORIDA 32503

TEL. (850) 478-8121 FAX (850) 476-1437

Email: rcsgt@aol.com

Scott Lunsford
Escambia County Tax Collector
P.O. Box 1312
Pensacola, FL 32591

CERTIFICATION: TITLE SEARCH FOR TDA

TAX DEED SALE DATE: 6-5-2017

TAX ACCOUNT NO.: 08-0419-500

CERTIFICATE NO.: 2014-4062

In compliance with Section 197.256, Florida Statutes, the following is a list of names and addresses of those persons, firms and/or agencies having legal interest in or claim against the above described property. The above referenced tax sale certificate is being submitted as proper notification of tax deed sale.

YES NO

Notify City of Pensacola, P.O. Box 12910, 32521

Notify Escambia County, 190 Governmental Center, 32502

Homestead for _____ tax year.

David Desrochers
10 Nimitz Court
Pensacola, FL 32507

Certified and delivered to Escambia County Tax Collector,
this 17th day of March, 2017.

SOUTHERN GUARANTY TITLE COMPANY

by: Richard S. Combs, President

NOTE: The above listed addresses are based upon current information available, but said addresses are not guaranteed to be true or correct.

Prepared by
Teri Kitchen, an employee of
First American Title Insurance Company
810 Scenic Highway
Pensacola, Florida 32503
(877)309-7217

Return to: Grantee

File No.: 1005-2864096

WARRANTY DEED

Made this Dec. 26, of 2012 by and between



Christopher W. Bailey, a single man

whose address is: **3905 Safari Street, Panama City Beach, FL 32408**
hereinafter called the "grantor", to

David Desrochers

whose post office address is: **10 Nimitz Court, Pensacola, FL 32507**
hereinafter called the "grantee":

(Which terms "Grantor" and "Grantee" shall include singular or plural, corporation or individual, and either sex, and shall include heirs, legal representatives, successors and assigns of the same)

Witnesseth, that the grantor, for and in consideration of the sum of Ten Dollars, (\$10.00) and other valuable considerations, receipt whereof is hereby acknowledged, hereby grants, bargains, sells, aliens, remises, releases, conveys and confirms unto the grantee, all that certain land situate in **Escambia County, Florida, to-wit:**

Lots 28 and 29, Block 17, SECOND ADDITION TO AERO VISTA, a Subdivision of a portion of Sections 50 and 51, Township 2 South Range 30 West, Escambia County, Florida, according to plat recorded in Plat Book 2, Pages 22A and 22B, of the Public Records of said county.

And Lot 30, Block 17, SECOND ADDITION TO AERO VISTA, a Subdivision of a portion of Sections 50 and 51, Township 2 South Range 30 West, Escambia County, Florida, according to plat recorded in Plat Book 2, Pages 22A and 22B, of the Public Records of said county.

Less and except the property contained in Official Records Book 1050, Page 490, of the Public Records of Escambia County, Florida.

Parcel Identification Number: **502S30-5010280-017**

The land is not the homestead of the Grantor under the laws and constitution of the State of Florida and neither the Grantor nor any person(s) for whose support the Grantor is responsible reside on or adjacent to the land.

Subject to all reservations, covenants, conditions, restrictions and easements of record and to all applicable zoning ordinances and/or restrictions imposed by governmental authorities, if any.

Together with all the tenements, hereditaments and appurtenances thereto belonging or in any way appertaining.

To Have and to Hold, the same in fee simple forever.

And the grantor hereby covenants with said grantee that the grantor is lawfully seized of said land in fee simple; that the grantor has good right and lawful authority to sell and convey said land; that the grantor hereby fully warrants the title to said land and will defend the same against the lawful claims of all persons whomsoever; and that said land is free of all encumbrances except taxes accruing subsequent to December 31st of 2012.

In Witness Whereof, the grantor has hereunto set their hand(s) and seal(s) the day and year first above written.

Christopher W. Bailey
Christopher W. Bailey

PLEASE SIGN

Signed, sealed and delivered in the presence of these witnesses:

Debra E. Price
Witness Signature

Print Name: Debra E. Price

Candace Spradlin
Witness Signature

Print Name: Candace Spradlin

WITNESS

WITNESS

State of Florida

County of Bay

The Foregoing Instrument was Acknowledged before me on 26 December 2017 by Christopher W. Bailey, a single man who is/are personally known to me or who has/have produced a valid driver's license as identification.

Candace Spradlin
Notary Public

Candace Spradlin
(Printed Name)

NOTARIZE



My Commission expires: May 30th, 2016

**STATE OF FLORIDA
COUNTY OF ESCAMBIA**

**CERTIFICATE OF NOTICE OF MAILING
NOTICE OF APPLICATION FOR TAX DEED**

CERTIFICATE # 04062 of 2014

I, PAM CHILDERS, CLERK OF THE CIRCUIT COURT OF ESCAMBIA COUNTY, FLORIDA, do hereby certify that I did on April 20, 2017, mail a copy of the foregoing Notice of Application for Tax Deed, addressed to:

DAVID DESROCHERS
10 NIMITZ CT
PENSACOLA, FL 32507

WITNESS my official seal this 20th day of April 2017.



PAM CHILDERS
CLERK OF THE CIRCUIT COURT
ESCAMBIA COUNTY, FLORIDA

By:
Emily Hogg
Deputy Clerk

WARNING

THERE ARE UNPAID TAXES ON PROPERTY WHICH YOU OWN OR IN WHICH YOU HAVE A LEGAL INTEREST. THE PROPERTY WILL BE SOLD AT PUBLIC AUCTION ON June 5, 2017, UNLESS THE TAXES ARE PAID. SHOULD YOU NEED FURTHER INFORMATION CONTACT THE CLERK OF THE CIRCUIT COURT IMMEDIATELY AT THE COUNTY COURTHOUSE IN PENSACOLA, FLORIDA, OR CALL 850-595-3793.

NOTICE OF APPLICATION FOR TAX DEED

NOTICE IS HEREBY GIVEN, That **BRISINGER FUND 1 LLC** holder of **Tax Certificate No. 04062**, issued the **1st day of June, A.D., 2014** has filed same in my office and has made application for a tax deed to be issued thereon. Said certificate embraces the following described property in the County of Escambia, State of Florida, to wit:

LT 28 & 29 BLK 17 ALSO BEG AT NE COR OF LT 30 WLY 193 13/100 FT TO E R/W LI OF NIMITZ ST BEING P T OF A CURVE HAVING A 25 FT RADIUS NELY & N ALG CURVE 29 72/100 FT TO NW COR OF LT 30 SELY 180 15/100 FT TO POB 2ND ADDN TO AERO VISTA PB 2 P 22 OR 6953 P 1208 SEC 50/51 T 2S R 30 CA 200

SECTION 50, TOWNSHIP 2 S, RANGE 30 W

TAX ACCOUNT NUMBER 080419500 (17-260)

The assessment of the said property under the said certificate issued was in the name of

DAVID DESROCHERS

Unless said certificate shall be redeemed according to law, the property described therein will be sold to the highest bidder at public auction at 9:00 A.M. on the **first Monday** in the month of June, which is the **5th day of June 2017**.

Dated this 20th day of April 2017.

In accordance with the AMERICANS WITH DISABILITIES ACT, if you are a person with a disability who needs special accommodation in order to participate in this proceeding you are entitled to the provision of certain assistance. Please contact Emily Hogg not later than seven days prior to the proceeding at Escambia County Government Complex, 221 Palafox Place Ste 110, Pensacola FL 32502. Telephone: 850-595-3793.



PAM CHILDERS
CLERK OF THE CIRCUIT COURT
ESCAMBIA COUNTY, FLORIDA

By:
Emily Hogg
Deputy Clerk

WARNING

THERE ARE UNPAID TAXES ON PROPERTY WHICH YOU OWN OR IN WHICH YOU HAVE A LEGAL INTEREST. THE PROPERTY WILL BE SOLD AT PUBLIC AUCTION ON June 5, 2017, UNLESS THE TAXES ARE PAID. SHOULD YOU NEED FURTHER INFORMATION CONTACT THE CLERK OF THE CIRCUIT COURT IMMEDIATELY AT THE COUNTY COURTHOUSE IN PENSACOLA, FLORIDA, OR CALL 850-595-3793.

NOTICE OF APPLICATION FOR TAX DEED

NOTICE IS HEREBY GIVEN, That **BRISINGER FUND 1 LLC** holder of **Tax Certificate No. 04062**, issued the **1st** day of **June, A.D., 2014** has filed same in my office and has made application for a tax deed to be issued thereon. Said certificate embraces the following described property in the County of Escambia, State of Florida, to wit:

LT 28 & 29 BLK 17 ALSO BEG AT NE COR OF LT 30 WLY 193 13/100 FT TO E R/W LI OF NIMITZ ST BEING P T OF A CURVE HAVING A 25 FT RADIUS NELY & N ALG CURVE 29 72/100 FT TO NW COR OF LT 30 SELY 180 15/100 FT TO POB 2ND ADDN TO AERO VISTA PB 2 P 22 OR 6953 P 1208 SEC 50/51 T 2S R 30 CA 200

SECTION 50, TOWNSHIP 2 S, RANGE 30 W

TAX ACCOUNT NUMBER 080419500 (17-260)

The assessment of the said property under the said certificate issued was in the name of

DAVID DESROCHERS

Unless said certificate shall be redeemed according to law, the property described therein will be sold to the highest bidder at public auction at 9:00 A.M. on the **first** Monday in the month of June, which is the **5th day of June 2017**.

Dated this 20th day of April 2017.

In accordance with the AMERICANS WITH DISABILITIES ACT, if you are a person with a disability who needs special accommodation in order to participate in this proceeding you are entitled to the provision of certain assistance. Please contact Emily Hogg not later than seven days prior to the proceeding at Escambia County Government Complex, 221 Palafox Place Ste 110, Pensacola FL 32502. Telephone: 850-595-3793.

Post Property:

10 NIMITZ CT 32507



**PAM CHILDERS
CLERK OF THE CIRCUIT COURT
ESCAMBIA COUNTY, FLORIDA**

By:
Emily Hogg
Deputy Clerk

WARNING

THERE ARE UNPAID TAXES ON PROPERTY WHICH YOU OWN OR IN WHICH YOU HAVE A LEGAL INTEREST. THE PROPERTY WILL BE SOLD AT PUBLIC AUCTION ON June 5, 2017, UNLESS THE TAXES ARE PAID. SHOULD YOU NEED FURTHER INFORMATION CONTACT THE CLERK OF THE CIRCUIT COURT IMMEDIATELY AT THE COUNTY COURTHOUSE IN PENSACOLA, FLORIDA, OR CALL 850-595-3793.

NOTICE OF APPLICATION FOR TAX DEED

NOTICE IS HEREBY GIVEN, That **BRISINGER FUND 1 LLC** holder of **Tax Certificate No. 04062**, issued the 1st day of **June, A.D., 2014** has filed same in my office and has made application for a tax deed to be issued thereon. Said certificate embraces the following described property in the County of Escambia, State of Florida, to wit:

LT 28 & 29 BLK 17 ALSO BEG AT NE COR OF LT 30 WLY 193 13/100 FT TO E R/W LI OF NIMITZ ST BEING P T OF A CURVE HAVING A 25 FT RADIUS NELY & N ALG CURVE 29 72/100 FT TO NW COR OF LT 30 SELY 180 15/100 FT TO POB 2ND ADDN TO AERO VISTA PB 2 P 22 OR 6953 P 1208 SEC 50/51 T 2S R 30 CA 200

SECTION 50, TOWNSHIP 2 S, RANGE 30 W

TAX ACCOUNT NUMBER 080419500 (17-260)

The assessment of the said property under the said certificate issued was in the name of

DAVID DESROCHERS

Unless said certificate shall be redeemed according to law, the property described therein will be sold to the highest bidder at public auction at 9:00 A.M. on the **first Monday** in the month of **June**, which is the **5th day of June 2017**.

Dated this 20th day of April 2017.

In accordance with the AMERICANS WITH DISABILITIES ACT, if you are a person with a disability who needs special accommodation in order to participate in this proceeding you are entitled to the provision of certain assistance. Please contact Emily Hogg not later than seven days prior to the proceeding at Escambia County Government Complex, 221 Palafox Place Ste 110, Pensacola FL 32502. Telephone: 850-595-3793.

Personal Services:

DAVID DESROCHERS
10 NIMITZ CT
PENSACOLA, FL 32507

PAM CHILDERS
CLERK OF THE CIRCUIT COURT
ESCAMBIA COUNTY, FLORIDA



By:
Emily Hogg
Deputy Clerk

ESCAMBIA COUNTY SHERIFF'S OFFICE
ESCAMBIA COUNTY, FLORIDA

NON-ENFORCEABLE RETURN OF SERVICE 17-260

Document Number: ECSO17CIV020056NON

Agency Number: 17-007040

Court: TAX DEED

County: ESCAMBIA

Case Number: CERT NO 04062 2014

Attorney/Agent:

PAM CHILDERS
CLERK OF COURT
TAX DEED

Plaintiff: RE: DAVID DESROCHERS

Defendant:

Type of Process: NOTICE OF APPLICATION FOR TAX DEED

Received this Writ on 4/20/2017 at 2:03 PM and served same at 11:50 AM on 4/21/2017 in ESCAMBIA COUNTY, FLORIDA, by serving POST PROPERTY , the within named, to wit: , .

POSTED TO PROPERTY PER INSTRUCTIONS FROM CLERKS OFFICE.

DAVID MORGAN, SHERIFF
ESCAMBIA COUNTY, FLORIDA

By: _____

T. HERNANDEZ, SDS

Service Fee: \$40.00
Receipt No: BILL

Printed By: NDSCHERER

WARNING

THERE ARE UNPAID TAXES ON PROPERTY WHICH YOU OWN OR IN WHICH YOU HAVE A LEGAL INTEREST. THE PROPERTY WILL BE SOLD AT PUBLIC AUCTION ON June 5, 2017, UNLESS THE TAXES ARE PAID. SHOULD YOU NEED FURTHER INFORMATION CONTACT THE CLERK OF THE CIRCUIT COURT IMMEDIATELY AT THE COUNTY COURTHOUSE IN PENSACOLA, FLORIDA, OR CALL 850-595-3793.

NOTICE OF APPLICATION FOR TAX DEED

NOTICE IS HEREBY GIVEN, That **BRISINGER FUND 1 LLC** holder of **Tax Certificate No. 04062**, issued the **1st** day of **June, A.D., 2014** has filed same in my office and has made application for a tax deed to be issued thereon. Said certificate embraces the following described property in the County of Escambia, State of Florida, to wit:

LT 28 & 29 BLK 17 ALSO BEG AT NE COR OF LT 30 WLY 193 13/100 FT TO E R/W LI OF NIMITZ ST BEING P T OF A CURVE HAVING A 25 FT RADIUS NELY & N ALG CURVE 29 72/100 FT TO NW COR OF LT 30 SELY 180 15/100 FT TO POB 2ND ADDN TO AERO VISTA PB 2 P 22 OR 6953 P 1208 SEC 50/51 T 2S R 30 CA 200

SECTION 50, TOWNSHIP 2 S, RANGE 30 W

TAX ACCOUNT NUMBER 080419500 (17-260)

The assessment of the said property under the said certificate issued was in the name of

DAVID DESROCHERS

Unless said certificate shall be redeemed according to law, the property described therein will be sold to the highest bidder at public auction at 9:00 A.M. on the **first** Monday in the month of June, which is the **5th day of June 2017**.

Dated this 20th day of April 2017.

In accordance with the AMERICANS WITH DISABILITIES ACT, if you are a person with a disability who needs special accommodation in order to participate in this proceeding you are entitled to the provision of certain assistance. Please contact Emily Hogg not later than seven days prior to the proceeding at Escambia County Government Complex, 221 Palafox Place Ste 110, Pensacola FL 32502. Telephone: 850-595-3793.

Post Property:

10 NIMITZ CT 32507



**PAM CHILDERS
CLERK OF THE CIRCUIT COURT
ESCAMBIA COUNTY, FLORIDA**

By:
Emily Hogg
Deputy Clerk

ESCAMBIA
SHERIFF'S
CIVIL UNIT

2017 APR 21

REC

ESCAMBIA COUNTY SHERIFF'S OFFICE
ESCAMBIA COUNTY, FLORIDA

NON-ENFORCEABLE RETURN OF SERVICE

17-260

Document Number: ECSO17CIV020014NON

Agency Number: 17-007001

Court: TAX DEED

County: ESCAMBIA

Case Number: CERT NO 04062 2014

Attorney/Agent:

PAM CHILDERS
CLERK OF COURT
TAX DEED

Plaintiff: RE DAVID DESROCHERS

Defendant:

Type of Process: NOTICE OF APPLICATION FOR TAX DEED

Individual

Received this Writ on 4/20/2017 at 2:01 PM and served same on DAVID DESROCHERS , at 11:50 AM on 4/21/2017 in ESCAMBIA COUNTY, FLORIDA, by delivering a true copy of this Writ together with a copy of the initial pleadings, if any, with the date and hour of service endorsed thereon by me.

DAVID MORGAN, SHERIFF
ESCAMBIA COUNTY, FLORIDA

By: _____

T. HERNANDEZ, SDS

Service Fee: \$40.00

Receipt No: BILL

Printed By: LCMITCHE

WARNING

THERE ARE UNPAID TAXES ON PROPERTY WHICH YOU OWN OR IN WHICH YOU HAVE A LEGAL INTEREST. THE PROPERTY WILL BE SOLD AT PUBLIC AUCTION ON June 5, 2017, UNLESS THE TAXES ARE PAID. SHOULD YOU NEED FURTHER INFORMATION CONTACT THE CLERK OF THE CIRCUIT COURT IMMEDIATELY AT THE COUNTY COURTHOUSE IN PENSACOLA, FLORIDA, OR CALL 850-595-3793.

NOTICE OF APPLICATION FOR TAX DEED

NOTICE IS HEREBY GIVEN, That **BRISINGER FUND 1 LLC** holder of **Tax Certificate No. 04062**, issued the **1st day of June, A.D., 2014** has filed same in my office and has made application for a tax deed to be issued thereon. Said certificate embraces the following described property in the County of Escambia, State of Florida, to wit:

LT 28 & 29 BLK 17 ALSO BEG AT NE COR OF LT 30 WLY 193 13/100 FT TO E R/W LI OF NIMITZ ST BEING P T OF A CURVE HAVING A 25 FT RADIUS NELY & N ALG CURVE 29 72/100 FT TO NW COR OF LT 30 SELY 180 15/100 FT TO POB 2ND ADDN TO AERO VISTA PB 2 P 22 OR 6953 P 1208 SEC 50/51 T 2S R 30 CA 200

SECTION 50, TOWNSHIP 2 S, RANGE 30 W

TAX ACCOUNT NUMBER 080419500 (17-260)

The assessment of the said property under the said certificate issued was in the name of

DAVID DESROCHERS

Unless said certificate shall be redeemed according to law, the property described therein will be sold to the highest bidder at public auction at 9:00 A.M. on the **first Monday** in the month of June, which is the **5th day of June 2017**.

Dated this 20th day of April 2017.

In accordance with the AMERICANS WITH DISABILITIES ACT, if you are a person with a disability who needs special accommodation in order to participate in this proceeding you are entitled to the provision of certain assistance. Please contact Emily Hogg not later than seven days prior to the proceeding at Escambia County Government Complex, 221 Palafox Place Ste 110, Pensacola FL 32502. Telephone: 850-595-3793.

Personal Services:

DAVID DESROCHERS
10 NIMITZ CT
PENSACOLA, FL 32507

PAM CHILDERS
CLERK OF THE CIRCUIT COURT
ESCAMBIA COUNTY, FLORIDA



By:
Emily Hogg
Deputy Clerk

ESCAMBIA COUNTY, FL
SHERIFF'S OFFICE
CIVIL UNIT

2017 APR 20 P 2:01

RECEIVED

DAVID DESROCHERS [17-260]
10 NIMITZ CT
PENSACOLA, FL 32507

9171 9690 0935 0128 9120 84

Contact ✓

PAM CHILDERS
 CLERK OF THE CIRCUIT COURT
 ARCHIVES AND RECORDS
 CHILDSUPPORT
 CIRCUIT CIVIL
 CIRCUIT CRIMINAL
 COUNTY CIVIL
 COUNTY CRIMINAL
 DOMESTIC RELATIONS
 FAMILY LAW
 JURY ASSEMBLY
 JUVENILE
 MENTAL HEALTH
 MIS
 OPERATIONAL SERVICES
 PROBATE
 TRAFFIC



BRANCH OFFICES
ARCHIVES AND RECORDS
JUVENILE DIVISION
CENTURY

CLERK TO THE BOARD OF
 COUNTY COMMISSIONERS
 OFFICIAL RECORDS
 COUNTY TREASURY
 AUDITOR

COUNTY OF ESCAMBIA
OFFICE OF THE
CLERK OF THE CIRCUIT COURT

PAM CHILDERS, CLERK OF THE CIRCUIT COURT
Tax Certificate Redeemed From Sale
Account: 080419500 Certificate Number: 004062 of 2014

Payor: JESSE DESROCHERS 10 NIMITZ CT PENSACOLA, FL 32507 Date 05/25/2017

Clerk's Check #	95677	Clerk's Total	\$470.25
Tax Collector Check #	1	Tax Collector's Total	\$7,493.52
		Postage	\$5.26
		Researcher Copies	\$2.00
		Total Received	\$7,971.03

PAM CHILDERS
 Clerk of the Circuit Court

Received By: _____
 Deputy Clerk

A handwritten signature in black ink, appearing to be "Jesse Desrochers", written over a horizontal line.

Escambia County Government Complex • 221 Palafox Place Ste 110 • PENSACOLA, FLORIDA 32502
 (850) 595-3793 • FAX (850) 595-4827 • <http://www.clerk.co.escambia.fl.us>

PAM CHILDERS
 CLERK OF THE CIRCUIT COURT
 ARCHIVES AND RECORDS
 CHILDSUPPORT
 CIRCUIT CIVIL
 CIRCUIT CRIMINAL
 COUNTY CIVIL
 COUNTY CRIMINAL
 DOMESTIC RELATIONS
 FAMILY LAW
 JURY ASSEMBLY
 JUVENILE
 MENTAL HEALTH
 MIS
 OPERATIONAL SERVICES
 PROBATE
 TRAFFIC



**COUNTY OF ESCAMBIA
 OFFICE OF THE
 CLERK OF THE CIRCUIT COURT**

**BRANCH OFFICES
 ARCHIVES AND RECORDS
 JUVENILE DIVISION
 CENTURY**

CLERK TO THE BOARD OF
 COUNTY COMMISSIONERS
 OFFICIAL RECORDS
 COUNTY TREASURY
 AUDITOR

**Case # 2014 TD 004062
 Redeemed Date 05/25/2017**

Name JESSE DESROCHERS 10 NIMITZ CT PENSACOLA, FL 32507

Clerk's Total = TAXDEED	\$470.25
Due Tax Collector = TAXDEED	\$7,493.52
Postage = TD2	\$5.26
ResearcherCopies = TD6	\$2.00

• For Office Use Only

Date	Docket	Desc	Amount Owed	Amount Due	Payee Name
------	--------	------	-------------	------------	------------

No Information Available - See Dockets

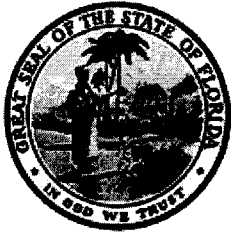

**PAM CHILDERS
CLERK OF THE CIRCUIT COURT
ESCAMBIA COUNTY, FLORIDA**

Tax Deed - Redemption Calculator

Account: 080419500 Certificate Number: 004062 of 2014

Redemption Yes No Application Date Interest Rate

	Final Redemption Payment ESTIMATED	Redemption Overpayment ACTUAL
	Auction Date <input type="text" value="06/05/2017"/>	Redemption Date <input type="text" value="05/25/2017"/>
Months	3	2
Tax Collector	<input type="text" value="\$7,164.85"/>	<input type="text" value="\$7,164.85"/>
Tax Collector Interest	\$322.42	\$214.95
Tax Collector Fee	<input type="text" value="\$6.25"/>	<input type="text" value="\$6.25"/>
Total Tax Collector	\$7,493.52	\$7,386.05 TC
Clerk Fee	<input type="text" value="\$130.00"/>	<input type="text" value="\$130.00"/>
Sheriff Fee	<input type="text" value="\$120.00"/>	<input type="text" value="\$120.00"/>
Legal Advertisement	<input type="text" value="\$200.00"/>	<input type="text" value="\$200.00"/>
App. Fee Interest	\$20.25	\$13.50
Total Clerk	\$470.25	\$463.50 CH
Postage	<input type="text" value="\$5.26"/>	<input type="text" value="\$5.26"/>
Researcher Copies	<input type="text" value="\$2.00"/>	<input type="text" value="\$2.00"/>
Total Redemption Amount	\$7,971.03	\$7,856.81
	Repayment Overpayment Refund Amount	<input type="text" value="\$114.22"/> + 40.00 =

redeemer

Notes



Pam Childers

Clerk of the Circuit Court and Comptroller, Escambia County

Clerk of Courts • County Comptroller • Clerk of the Board of County Commissioners • Recorder •

May 31, 2017

JESSE DESROCHERS
10 NIMITZ CT
PENSACOLA FL 32507

Dear Redeemer,

The records of this office show that an application for a tax deed had been made on the property represented by the numbered certificate listed below. The property was redeemed by you. A refund of unused fees/interest is enclosed.

If you have any questions, please feel free to give me a call.

CERTIFICATE NUMBER

REFUND

2014 TD 004062

\$154.22

TOTAL \$154.22

Very truly yours,

PAM CHILDERS
Clerk of Circuit Court

By:

Emily Hogg
Tax Deed Division



Pam Childers

Clerk of the Circuit Court and Comptroller, Escambia County

Clerk of Courts • County Comptroller • Clerk of the Board of County Commissioners • Recorder •

June 1, 2017

BRISINGER FUND 1 LLC
1338 S FOOTHILL DRIVE #129
SALT LAKE CITY UT 84108

Dear Certificate Holder:

The records of this office show that an application for a tax deed had been made on the property represented by the numbered certificate listed below. The property redeemed prior to sale; therefore your application fees are now refundable.

TAX CERT	APP FEES	INTEREST	TOTAL
2014 TD 004062	\$450.00	\$13.50	\$463.50
2014 TD 004020	\$450.00	\$13.50	\$463.50
2014 TD 003625	\$450.00	\$13.50	\$463.50
2014 TD 005055	\$450.00	\$13.50	\$463.50
2014 TD 001551	\$450.00	\$13.50	\$463.50

TOTAL \$2,317.00

Very truly yours,

PAM CHILDERS
Clerk of Circuit Court

By:

Emily Hogg
Tax Deed Division

THE SUMMATION WEEKLY

NOTICE OF APPLICATION FOR TAX DEED

NOTICE IS HEREBY GIVEN, That BRISINGER FUND 1 LLC holder of Tax Certificate No. 04062, issued the 1st day of June, A.D., 2014 has filed same in my office and has made application for a tax deed to be issued thereon. Said certificate embraces the following described property in the County of Escambia, State of Florida, to wit:

LT 28 & 29 BLK 17 ALSO BEG AT NE COR OF LT 30 WLY 193 13/100 FT TO E R/W LI OF NIMITZ ST BEING P T OF A CURVE HAVING A 25 FT RADIUS NELY & N ALG CURVE 29 72/100 FT TO NW COR OF LT 30 SELY 180 15/100 FT TO POB 2ND ADDN TO AERO VISTA PB 2 P 22 OR 6953 P 1208 SEC 50/51 T 2S R 30 CA 200 SECTION 50, TOWNSHIP 2 S, RANGE 30 W TAX ACCOUNT NUMBER 080419500 (17-260)

The assessment of the said property under the said certificate issued was in the name of

DAVID DESROCHERS

Unless said certificate shall be redeemed according to law, the property described therein will be sold to the highest bidder at public auction at 9:00 A.M. on the first Monday in the month of June, which is the 5th day of June 2017.

Dated this 20th day of April 2017.

In accordance with the AMERICANS WITH DISABILITIES ACT, if you are a person with a disability who needs special accommodation in order to participate in this proceeding you are entitled to the provision of certain assistance. Please contact Emily Hogg not later than seven days prior to the proceeding at Escambia County Government Complex, 221 Palafox Place Ste 110, Pensacola FL 32502. Telephone: 850-595-3793.

PAM CHILDERS
CLERK OF THE CIRCUIT COURT
ESCAMBIA COUNTY, FLORIDA

By:
Emily Hogg
Deputy Clerk

4WR5/3-5/24TD

Escambia-Santa Rosa Bar Association Since 2014

Before the undersigned authority personally appeared Malcolm G. Ballinger who under oath says that he is Publisher of The Summation Weekly Newspaper published at Pensacola in Escambia & Santa Rosa County, Florida; that the attached copy of the advertisement, being a notice in the matter of 2014 TD 04062 in the Escambia County Court was published in said newspaper in and was printed and released on the start date of May 3, 2017 and end date of May 24, 2017.

Affiant further says that the said Summation Weekly is a newspaper published at Pensacola, in said Escambia & Santa Rosa Counties, Florida, and that the said newspaper has heretofore been continuously published in said Escambia & Santa Rosa Counties, Florida each week and has been entered as second class mail matter at the post office in Pensacola, in said Escambia County, Florida, for a period of one year next preceding the first publication of the attached copy of advertisement; and affiant further says that he has neither paid nor promised any person, firm or corporation any discount, rebate, commission or refund for the purpose of securing this advertisement for publication of the said newspaper.

X



MALCOLM G. BALLINGER, PUBLISHER

STATE OF FLORIDA
COUNTY OF ESCAMBIA

The foregoing instrument was acknowledged before me, Bridget A. Roberts, this 1st day of June 2017, by Malcolm G. Ballinger, who is personally known to me.

X



BRIDGET A. ROBERTS, NOTARY PUBLIC



Bridget A. Roberts
NOTARY PUBLIC
STATE OF FLORIDA
Comm# GG023500
Expires 8/22/2020