

TAX COLLECTOR'S CERTIFICATION

**Application
Date / Number
Apr 15, 2014 / 140015**

This is to certify that the holder listed below of Tax Sale Certificate Number **2012 / 1638.0000** , issued the **1st day of June, 2012**, and which encumbers the following described property located in the County of Escambia, State of Florida to wit: **Parcel ID Number: 03-0900-001**

Certificate Holder:
PPF HOLDINGS III LTD.
U.S. BANK CUSTODIAN FOR PPF HO
P.O. BOX 645051
CINCINNATI, OHIO 45264

Property Owner:
KIMBROUGH COREY DANIELLE & KIMBROUGH JOSEPH A &
1111 HOPE DR
PENSACOLA , FLORIDA 32534

Legal Description:

BEG AT NE COR OF SEC W ALG N LI OF SEC 457 84/100 FT SLY 89 DEG 56 MIN 30 SEC LEFT 39 90/100 FT TO INTER OF S R/W LI OF HOPE DR (66 FT R/W) AND E R/W ...

See attachment for full legal description.

has surrendered same in my office and made written application for tax deed in accordance with Florida Statutes. I certify that the following tax certificates, interest, ownership and encumbrance report fee, and Tax Collector's fees have been paid:

CERTIFICATES OWNED BY APPLICANT AND FILED IN CONNECTION WITH THIS TAX DEED APPLICATION:

Cert. Year	Certificate Number	Date of Sale	Face Amt	T/C Fee	Interest	Total
2012	1638.0000	06/01/12	\$671.10	\$0.00	\$33.56	\$704.66

CERTIFICATES REDEEMED BY APPLICANT OR INCLUDED (COUNTY) IN CONNECTION WITH THIS APPLICATION:

Cert. Year	Certificate Number	Date of Sale	Face Amt	T/C Fee	Interest	Total
2013	1464.0000	06/01/13	\$649.25	\$6.25	\$32.46	\$687.96

1. Total of all Certificates in Applicant's Possession and Cost of the Certificates Redeemed by Applicant or Included (County)
2. Total of Delinquent Taxes Paid by Tax Deed Application
3. Total of Current Taxes Paid by Tax Deed Applicant (2013)
4. Ownership and Encumbrance Report Fee
5. Tax Deed Application Fee
6. Total Certified by Tax Collector to Clerk of Court
7. Clerk of Court Statutory Fee
8. Clerk of Court Certified Mail Charge
9. Clerk of Court Advertising Charge
10. Sheriff's Fee
11. _____
12. Total of Lines 6 thru 11
13. Interest Computed by Clerk of Court Per Florida Statutes.....(%)
14. One-Half of the assessed value of homestead property. If applicable pursuant to section 197.502, F.S.
15. Statutory (Opening) Bid; Total of Lines 12 thru 14
16. Redemption Fee
17. Total Amount to Redeem

\$1,392.62
\$0.00
\$582.87
\$250.00
\$75.00
\$2,300.49
\$2,300.49
\$31,580.00
\$6.25

*Done this 15th day of April, 2014

TAX COLLECTOR, ESCAMBIA COUNTY, FLORIDA

By Candice Lewis

Date of Sale: September 2, 2014

* This certification must be surrendered to the Clerk of the Circuit Court no later than ten days after this date.

FORM 513
(r.12/00)

TAX COLLECTOR'S CERTIFICATION

APPLICATION DATE

4/15/2014

FULL LEGAL DESCRIPTION
Parcel ID Number: 03-0900-001

April 22, 2014
Tax Year: 2011
Certificate Number: 1638.0000

BEG AT NE COR OF SEC W ALG N LI OF SEC 457 84/100 FT SLY 89 DEG 56 MIN 30 SEC LEFT 39 90/100 FT TO INTER OF S R/W LI OF HOPE DR (66 FT R/W) AND E R/W LI OF BAKER LANE (50 FT R/W) FOR POB CONT S ALG E R/W LI OF BAKER LANE 125 FT E 90 DEG 6 MIN 40 SEC LEFT 144 78/100 FT N 89 DEG 58 MIN 30 SEC LEFT 125 FT TO S R/W LI OF HOPE DR W ALG S LI OF HOPE DR 144 59/100 FT TO POB OR 6343 P 38

Notice to Tax Collector of Application for Tax Deed

TO: Tax Collector of Escambia County

In accordance with Florida Statutes, I,

**PPF HOLDINGS III LTD.
U.S. BANK CUSTODIAN FOR PPF HO
P.O. BOX 645051
CINCINNATI, Ohio, 45264**

holder of the following tax sale certificate hereby surrender same to the Tax Collector and make tax deed application thereon:

Certificate No.	Parcel ID Number	Date	Legal Description
1638.0000	03-0900-001	06/01/2012	BEG AT NE COR OF SEC W ALG N LI OF SEC 457 84/100 FT SLY 89 DEG 56 MIN 30 SEC LEFT 39 90/100 FT TO INTER OF S R/W LI OF HOPE DR (66 FT R/W) AND E R/W LI OF BAKER LANE (50 FT R/W) FOR POB CONT S ALG E R/W LI OF BAKER LANE 125 FT E 90 DEG 6 MIN 40 SEC LEFT 144 78/100 FT N 89 DEG 58 MIN 30 SEC LEFT 125 FT TO S R/W LI OF HOPE DR W ALG S LI OF HOPE DR 144 59/100 FT TO POB OR 6343 P 38

2013 TAX ROLL

**KIMBROUGH COREY DANIELLE &
KIMBROUGH JOSEPH A &
1111 HOPE DR
PENSACOLA , Florida 32534**

I agree to pay all delinquent taxes, redeem all outstanding certificates not in my possession, pay any omitted taxes, and pay current taxes, if due, covering the land, and pay any interest earned (a) on tax certificates not in my possession, (b) on omitted taxes or (c) on delinquent taxes. I also agree to pay all Tax Collector's fees, ownership and encumbrance reports costs, Clerk of the Court costs, charges and fees and Sheriff's costs, if applicable. Attached is the above-mentioned tax sale certificate on which this application is based and all other certificates of the same legal description which are in my possession.

tda2012 (Taimur Jamil)
Applicant's Signature

04/15/2014
Date



Chris Jones Escambia County Property Appraiser

Real Estate Search

Tangible Property Search

Sale List

Amendment 1/Portability Calculations

[Back](#)

← Navigate Mode Account Reference →

[Printer Friendly Version](#)

General Information	
Reference:	261S301101001001
Account:	030900001
Owners:	KIMBROUGH COREY DANIELLE & KIMBROUGH JOSEPH A & KIMBROUGH COYA DENISE
Mail:	1111 HOPE DR PENSACOLA, FL 32534
Situs:	1111 HOPE DR 32534
Use Code:	SINGLE FAMILY RESID
Taxing Authority:	COUNTY MSTU
Tax Inquiry:	Open Tax Inquiry Window
Tax Inquiry link courtesy of Janet Holley Escambia County Tax Collector	

2013 Certified Roll Assessment	
Improvements:	\$55,180
Land:	\$7,980
Total:	\$63,160
Save Our Homes:	\$63,160
Disclaimer	
Amendment 1/Portability Calculations	

Sales Data					
Sale Date	Book	Page	Value	Type	Official Records (New Window)
06/16/2008	6343	38	\$89,900	WD	View Instr
07/2004	5471	249	\$85,900	WD	View Instr
11/2002	5016	1979	\$36,000	WD	View Instr
04/2002	5058	1743	\$36,000	QC	View Instr
04/2002	5016	1976	\$36,000	QC	View Instr
Official Records Inquiry courtesy of Pam Childers Escambia County Clerk of the Circuit Court and Comptroller					

2013 Certified Roll Exemptions
HOMESTEAD EXEMPTION

Legal Description
BEG AT NE COR OF SEC W ALG N LI OF SEC 457 84/100 FT SLY 89 DEG 56 MIN 30 SEC LEFT 39 90/100 FT TO INTER...

Extra Features
None

Parcel Information

[Launch Interactive Map](#)

Section Map Id:
25-1S-30-1

Approx. Acreage:
0.4100

Zoned:
R-6

Evacuation & Flood Information
[Open Report](#)

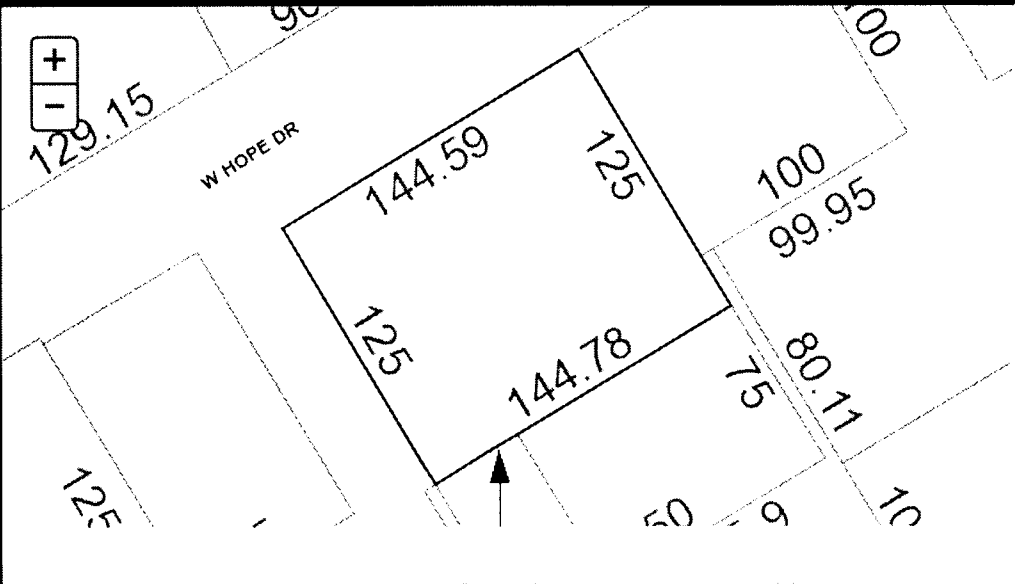

Buildings

Building 1 - Address: 1111 HOPE DR, Year Built: 1974, Effective Year: 1974

Structural Elements
DECOR/MILLWORK-BELOW AVERAGE
DWELLING UNITS-1.00

EXTERIOR WALL-*BRICK-FACE*
EXTERIOR WALL-*CONCRETE BLOCK*
FLOOR COVER-*CARPET*
FOUNDATION-*SLAB ON GRADE*
HEAT/AIR-*HEAT W/DUCTS*
INTERIOR WALL-*DRYWALL-PLASTER*
INTERIOR WALL-*PANEL-PLYWOOD*
NO. PLUMBING FIXTURES-*8.00*
NO. STORIES-*1.00*
ROOF COVER-*COMPOSITION SHG*
ROOF FRAMING-*GABLE*
STRUCTURAL FRAME-*WOOD FRAME*

 Areas - 2616 Total SF
BASE AREA - 2142
GARAGE UNFIN - 462
OPEN PORCH FIN - 12

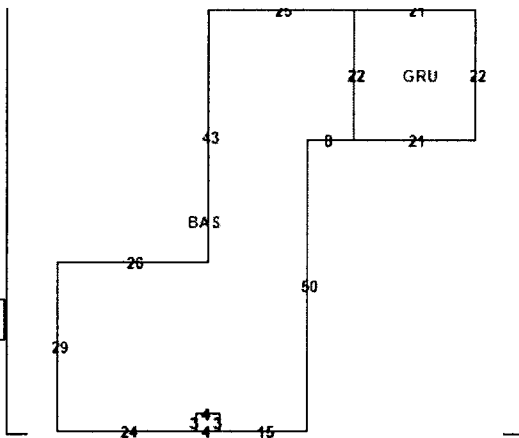

Images

None

The primary use of the assessment data is for the preparation of the current year tax roll. No responsibility or liability is assumed for inaccuracies or errors.

Last updated: 04/23/2014 (r: 4096)

Southern Guaranty Title Company

4400 Bayou Boulevard, Suite 13B

Pensacola, Florida 32503

Telephone: 850-478-8121

Facsimile: 850-476-1437

OWNERSHIP AND ENCUMBRANCE REPORT

File No.: 11195

May 27, 2014

Escambia County Tax Collector

P.O. Box 1312

Pensacola, Florida 32569

Pursuant to your request, the Company has caused a search to be made of the Public Records of Escambia County, Florida, solely as revealed by records maintained from 05-27-1994, through 05-27-2014, and said search reveals the following:

1. THE GRANTEE(S) OF THE LAST DEED(S) OF RECORD IS:

Corey Dannelle Kimbrough, Joseph Anthony Kimbrough and Coya Denise Kimbrough

2. The land covered by this Report is:

LEGAL DESCRIPTION IS ATTACHED HERETO AND MADE A PART HEREOF

3. The following unsatisfied mortgages, liens and judgments affecting the land covered by this Report appear of record:

SEE CONTINUATION PAGE ATTACHED HERETO AND MADE A PART HEREOF

4. Taxes:

SEE CONTINUATION PAGE ATTACHED HERETO AND MADE A PART HEREOF

The foregoing report is prepared and furnished for information only, is not intended to constitute or imply any opinion, warranty, guaranty, insurance, or similar assurance as to the status of title, and no determination has been made of the authenticity of any instrument described or referred to herein. The name search for the purposes of determining applicable judgments and liens is limited to the apparent record owner(s) shown herein. No attempt has been made to determine whether the land is subject to liens or assessments which are not shown as existing liens by the public records. The Company's liability hereunder shall not exceed the cost of this Report, or \$1,000.00 whichever is less.

THIS REPORT SHALL NOT BE USED FOR THE ISSUANCE OF TITLE INSURANCE.

Southern Guaranty Title Company

By: 

May 27, 2014

**OWNERSHIP AND ENCUMBRANCE REPORT
LEGAL DESCRIPTION**

File No.: 11195

May 27, 2014

261S301101001001 - Full Legal Description

BEG AT NE COR OF SEC W ALG N LI OF SEC 457 84/100 FT SLY 89 DEG 56 MIN 30 SEC LEFT 39 90/100 FT TO INTER OF S R/W LI OF HOPE DR (66 FT R/W) AND E R/W LI OF BAKER LANE (50 FT R/W) FOR POB CONT S ALG E R/W LI OF BAKER LANE 125 FT E 90 DEG 6 MIN 40 SEC LEFT 144 78/100 FT N 89 DEG 58 MIN 30 SEC LEFT 125 FT TO S R/W LI OF HOPE DR W ALG S LI OF HOPE DR 144 59/100 FT TO POB OR 6343 P 38

**OWNERSHIP AND ENCUMBRANCE REPORT
CONTINUATION PAGE**

File No.: 11195

May 27, 2014

UNSATISFIED MORTGAGES, LIENS AND JUDGMENTS AFFECTING THE LAND COVERED BY THIS REPORT THAT APPEAR OF RECORD:

1. Possible Certificate of Delinquency filed by Denique C. Blackwell against Joseph A. Kimbrough recorded in O.R. Book 6856, page 444.
2. Taxes for the year 2011-2013 delinquent. The assessed value is \$63,160.00. Tax ID 03-0900-001.

PLEASE NOTE THE FOLLOWING:

- A. Subject to current year taxes.
- B. Taxes and assessments due now or in subsequent years.
- C. Subject to Easements, Restrictions and Covenants of record.
- D. Encroachments, overlaps, boundary line disputes, and any other matters which would be disclosed by an accurate survey and inspection of the premises.
- E. Oil, gas and mineral or any other subsurface rights of any kind or nature.

SOUTHERN GUARANTY TITLE COMPANY

4400 BAYOU BLVD., SUITE 13-B, CORDOVA SQUARE
PENSACOLA, FLORIDA 32503

TEL. (850) 478-8121 FAX (850) 476-1437

Email: rcsgr@aol.com

Janet Holley
Escambia County Tax Collector
P.O. Box 1312
Pensacola, FL 32596

CERTIFICATION: TITLE SEARCH FOR TDA

TAX DEED SALE DATE: 9-2-2014

TAX ACCOUNT NO.: 03-0900-001

CERTIFICATE NO.: 2012-1638

In compliance with Section 197.256, Florida Statutes, the following is a list of names and addresses of those persons, firms and/or agencies having legal interest in or claim against the above described property. The above referenced tax sale certificate is being submitted as proper notification of tax deed sale.

YES NO

Notify City of Pensacola, P.O. Box 12910, 32521

Notify Escambia County, 190 Governmental Center, 32502

Homestead for 2013 tax year.

Corey Dannelle Kimbrough
Joseph Anthony Kimbrough
Coya Denise Kimbrough
1111 Hope Dr.
Pensacola, FL 32534

Denique C. Blackwell
1323 North J Street, A
Pensacola, FL 32501

Certified and delivered to Escambia County Tax Collector,
this 28th day of May, 2014.

SOUTHERN GUARANTY TITLE COMPANY

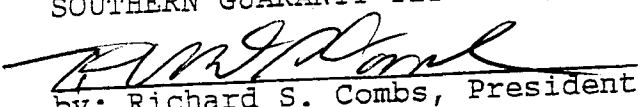
by: Richard S. Combs, President

NOTE: The above listed addresses are based upon current information available, but said addresses are not guaranteed to be true or correct.

Documentary stamps in the amount of \$629.30
paid on a purchase price of \$89,900.00

THIS INSTRUMENT PREPARED BY AND RETURN TO:
Charles Curry
Stonewall Title Group
100 North Spring Street, Suite 1
Pensacola, Florida 32502
Property Appraisers Parcel Identification (Folio) Number: 261S301101001001

SPACE ABOVE THIS LINE FOR RECORDING DATA

THIS WARRANTY DEED, made the 16th day of June, 2008 by ISAAC BRIGHAM, A UNMARRIED MAN ,
whose post office address is 1111 HOPE DRIVE, PENSACOLA, FLORIDA 32534 herein called the Grantor, to
COREY DANIELLE KIMBROUGH, A Minor Child, JOSEPH ANTHONY KIMBROUGH, A Minor
Child, and COYA DENISE KIMBROUGH, A Minor Child, tenants in common whose post office address is
1111 HOPE DRIVE, PENSACOLA, FLORIDA 32534, hereinafter called the Grantees:
(Wherever used herein the terms "Grantor" and "Grantee" include all the parties to this instrument and the heirs, legal
representatives and assigns of individuals, and the successors and assigns of corporations)

W I T N E S S E T H: That the Grantor, for and in consideration of the sum of TEN AND 00/100'S (\$10.00)
Dollars and other valuable considerations, receipt whereof is hereby acknowledged, hereby grants, bargains, sells,
aliens, remises, releases, conveys and confirms unto the Grantee all that certain land situate in ESCAMBIA County,
State of Florida, viz.:

SEE EXHIBIT "A" ATTACHED HERETO AND MADE A PART HEREOF

Subject to zoning, restrictions, prohibitions and other requirements imposed by governmental
authorities, and easements, restrictions and reservations of record and to taxes for the current year
and thereafter.

TOGETHER, with all the tenements, hereditaments and appurtenances thereto belonging or in anywise
appertaining.

TO HAVE AND TO HOLD, the same in fee simple forever.

AND, the Grantor hereby covenants with said Grantees that the Grantor is lawfully seized of said land in fee simple;
that the Grantor has good right and lawful authority to sell and convey said land, and hereby warrants the title to said
land and will defend the same against the lawful claims of all persons whomsoever; and that said land is free of all
encumbrances, except taxes accruing subsequent to December 31, 2007.

IN WITNESS WHEREOF, the said Grantor has signed and sealed these presents the day and year first above
written.

Signed, sealed and delivered in the presence of:

Kathleen A Curry
Witness #1 Signature

Kathleen A Curry
Witness #1 Printed Name

Hilary Pember
Witness #2 Signature

HILARY Pember
Witness #2 Printed Name

Isaac Brigham
ISAAC BRIGHAM

**STATE OF FLORIDA
COUNTY OF ESCAMBIA**

The foregoing instrument was acknowledged before me this 16th day of June, 2008 by ISAAC BRIGHAM who is
personally known to me or has produced Drivers License as identification.

SEAL

Kathleen A Curry
Notary Public

Printed Notary Name

KATHLEEN A. CURRY
Notary Public, State of Florida
My comm. exp. April 26, 2012
Comm. No. DD 780647

My Commission Expires:

EXHIBIT "A"

Commence at the Northeast corner of Section 26, Township 1 South, Range 30 West, Escambia County, Florida; thence West along the North line of said Section for a distance of 457.84 feet; thence Southerly deflecting 89 degrees 56 minutes 30 seconds left for a distance of 39.90 feet to the point of intersection of the South right of way line of Hope Drive (66 foot right of way) and the East right of way line of Baker Lane (50 foot right of way) and the Point of Beginning; thence continue South along the east right of way line of said Baker Lane for a distance of 125.00 feet; thence East deflecting 90 degrees 06 minutes 40 seconds left for 144.78 feet; thence North deflecting 89 degrees 58 minutes 30 seconds left for a distance of 125.00 feet to the South right of way line of said Hope Drive; thence West along said South right of way line for a distance of 144.59 feet to the Point of Beginning. Situated in Section 26, Township 1 South, Range 30 West, Escambia County, Florida.

**RESIDENTIAL SALES
ABUTTING ROADWAY
MAINTENANCE DISCLOSURE**

ATTENTION: Pursuant to Escambia County Code of Ordinances Chapter 1-29.2, Article V, sellers of residential lots are required to disclose to buyers whether abutting roadways will be maintained by Escambia County, and if not, what person or entity will be responsible for maintenance. The disclosure must additionally provide that Escambia County does not accept roads for maintenance that have not been built or improved to meet county standards. Escambia County Code of Ordinances Chapter 1-29.2, Article V requires this disclosure be attached along with other attachments to the deed or other method of conveyance required to be made part of the public records of Escambia County, Florida. Note: Acceptance for filing by County employees of this disclosure shall in no way be construed as an acknowledgement by the County of the veracity of any disclosure statements.

Name of Roadway: **1111 HOPE DRIVE**

Legal Address of Property: **1111 HOPE DRIVE, PENSACOLA, FLORIDA 32534**

The County has accepted () has not accepted the abutting roadway for maintenance.

This form completed by: **Stonewall Title Group
100 North Spring Street, Suite 1
Pensacola, Florida 32502**

AS TO SELLER(S):

Kathleen A Curry
Witness' Name: Kathleen A Curry

Isaac Brigham
ISAAC BRIGHAM

Wilma Zember
Witness' Name: Wilma Zember

Witness' Name: _____

Witness' Name: _____

AS TO BUYER(S):

Kathleen A Curry Katie R Booker as guardian for Corey Dannelle Kimbrough
Witness' Name: Kathleen A Curry KATIE R. BOOKER as Guardian for
COREY DANIELLE KIMBROUGH

Teri Van Landuyt Katie R Booker as guardian for Joseph Anthony Kimbrough
Witness' Name: Teri Van Landuyt KATIE R. BOOKER as Guardian for
JOSEPH ANTHONY KIMBROUGH

Katie R Booker as guardian for Coya Denise Kimbrough
Witness' Name: KATIE R. BOOKER as Guardian for
COYA DENISE KIMBROUGH

IN THE CIRCUIT COURT OF FLORIDA
FIRST JUDICIAL CIRCUIT, IN AND
FOR ESCAMBIA COUNTY, CIVIL ACTION

CASE NO.: 11-0101593-DR JD/DIV: V
UCN: 17 2011 DR 101593 XXXX JV

BLACKWELL, DENIQUE C.
1323 NORTH J STREET, A
PENSACOLA, FL 32501
Petitioner.

vs.

KIMBROUGH, JOSEPH A.
1111 W. HOPE DRIVE
PENSACOLA, FL 32534
Respondent.

ERNIE LEE MAGAHA
CLERK OF CIRCUIT COURT
ESCAMBIA COUNTY FL

2012 MAY -8 P 4: 17

DOMESTIC RELATIONS
FILED & RECORDED

JUDGMENT/CERTIFICATE OF DELINQUENCY

The undersigned, being the duly authorized local depository for court-ordered support payments pursuant to F.S. 61.181, in ESCAMBIA County, certifies that KIMBROUGH, JOSEPH A. has failed to pay into the depository the court-ordered support payment mandated by the current Support Order in this cause. As of this date, the total support arrearage is \$1,950.00 balance at terms, not including any costs or fees. Statutory interest automatically accrues on all past due support pursuant to F.S.55.03.

I further certify that KIMBROUGH, JOSEPH A. was issued a Notice of Delinquency on 01/18/2012, and 30 or more days have elapsed since the referenced delinquent payment was due. Pursuant to F.S. 61.14 this Certificate is a Final Judgment by operation of law for all past due and future payments together with all applicable costs and fees as provided by law for which execution may issue and which has the full force, effect and attributes of a Judgment entered by a Court in the State of Florida.

Dated May 8, 2012.

ESCAMBIA CTY CLERK OF COURT ERNIE LEE MAGAHA

By:  Clerk

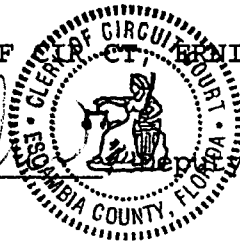

Case: 2011 DR 101593 JV

00012528758

Dkt: DJ2177IV Pg#: (

STATE OF FLORIDA
COUNTY OF ESCAMBIA

CERTIFICATE OF NOTICE OF MAILING
NOTICE OF APPLICATION FOR TAX DEED

CERTIFICATE # 01638 of 2012

I, PAM CHILDERS, CLERK OF THE CIRCUIT COURT OF ESCAMBIA COUNTY, FLORIDA, do hereby certify that I did on July 31, 2014, mail a copy of the foregoing Notice of Application for Tax Deed, addressed to:

COREY DANNELLE KIMBROUGH 1111 HOPE DR PENSACOLA, FL 32534	JOSEPH A KIMBROUGH 1111 HOPE DR PENSACOLA, FL 32534
COYA DENISE KIMBROUGH 1111 HOPE DR PENSACOLA, FL 32534	DENIQUE C BLACKWELL 1323 NORTH J STREET A PENSACOLA FL 32501
ESCAMBIA COUNTY C/O JUVENILE 1800 ST MARY AVE PENSACOLA FL 32501	

WITNESS my official seal this 31th day of July 2014.

PAM CHILDERS
CLERK OF THE CIRCUIT COURT
ESCAMBIA COUNTY, FLORIDA

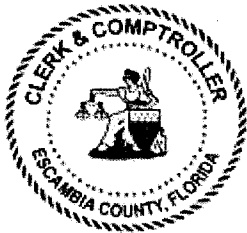

By:
Emily Hogg
Deputy Clerk

WARNING

THERE ARE UNPAID TAXES ON PROPERTY WHICH YOU OWN OR IN WHICH YOU HAVE A LEGAL INTEREST. THE PROPERTY WILL BE SOLD AT PUBLIC AUCTION ON September 2, 2014, UNLESS THE TAXES ARE PAID. SHOULD YOU NEED FURTHER INFORMATION CONTACT THE CLERK OF THE CIRCUIT COURT IMMEDIATELY AT THE COUNTY COURTHOUSE IN PENSACOLA, FLORIDA, OR CALL 850-595-3793.

NOTICE OF APPLICATION FOR TAX DEED

NOTICE IS HEREBY GIVEN, That PPF HOLDINGS III LTD holder of Tax Certificate No. 01638, issued the 1st day of June, A.D., 2012 has filed same in my office and has made application for a tax deed to be issued thereon. Said certificate embraces the following described property in the County of Escambia, State of Florida, to wit:

BEG AT NE COR OF SEC W ALG N LI OF SEC 457 84/100 FT SLY 89 DEG 56 MIN 30 SEC LEFT 39 90/100 FT TO INTER OF S R/W LI OF HOPE DR (66 FT R/W) AND E R/W LI OF BAKER LANE (50 FT R/W) FOR POB CONT S ALG E R/W LI OF BAKER LANE 125 FT E 90 DEG 6 MIN 40 SEC LEFT 144 78/100 FT N 89 DEG 58 MIN 30 SEC LEFT 125 FT TO S R/W LI OF HOPE DR W ALG S LI OF HOPE DR 144 59/100 FT TO POB OR 6343 P 38

SECTION 26, TOWNSHIP 1 S, RANGE 30 W

TAX ACCOUNT NUMBER 030900001 (14-588)

The assessment of the said property under the said certificate issued was in the name of

COREY DANIELLE KIMBROUGH and JOSEPH A KIMBROUGH and COYA DENISE KIMBROUGH

Unless said certificate shall be redeemed according to law, the property described therein will be sold to the highest bidder at public auction at 9:00 A.M. on the first Tuesday in the month of September, which is the 2nd day of September 2014.

Dated this 31st day of July 2014.

In accordance with the AMERICANS WITH DISABILITIES ACT, if you are a person with a disability who needs special accommodation in order to participate in this proceeding you are entitled to the provision of certain assistance. Please contact Emily Hogg not later than seven days prior to the proceeding at Escambia County Government Complex, 221 Palafox Place Ste 110, Pensacola FL 32502. Telephone: 850-595-3793.

PAM CHILDERS
CLERK OF THE CIRCUIT COURT
ESCAMBIA COUNTY, FLORIDA



By:
Emily Hogg
Deputy Clerk

WARNING

THERE ARE UNPAID TAXES ON PROPERTY WHICH YOU OWN OR IN WHICH YOU HAVE A LEGAL INTEREST. THE PROPERTY WILL BE SOLD AT PUBLIC AUCTION ON September 2, 2014, UNLESS THE TAXES ARE PAID. SHOULD YOU NEED FURTHER INFORMATION CONTACT THE CLERK OF THE CIRCUIT COURT IMMEDIATELY AT THE COUNTY COURTHOUSE IN PENSACOLA, FLORIDA, OR CALL 850-595-3793.

NOTICE OF APPLICATION FOR TAX DEED

NOTICE IS HEREBY GIVEN, That **PPF HOLDINGS III LTD** holder of Tax Certificate No. 01638, issued the 1st day of June, A.D., 2012 has filed same in my office and has made application for a tax deed to be issued thereon. Said certificate embraces the following described property in the County of Escambia, State of Florida, to wit:

BEG AT NE COR OF SEC W ALG N LI OF SEC 457 84/100 FT SLY 89 DEG 56 MIN 30 SEC LEFT 39 90/100 FT TO INTER OF S R/W LI OF HOPE DR (66 FT R/W) AND E R/W LI OF BAKER LANE (50 FT R/W) FOR POB CONT S ALG E R/W LI OF BAKER LANE 125 FT E 90 DEG 6 MIN 40 SEC LEFT 144 78/100 FT N 89 DEG 58 MIN 30 SEC LEFT 125 FT TO S R/W LI OF HOPE DR W ALG S LI OF HOPE DR 144 59/100 FT TO POB OR 6343 P 38

SECTION 26, TOWNSHIP 1 S, RANGE 30 W

TAX ACCOUNT NUMBER 030900001 (14-588)

The assessment of the said property under the said certificate issued was in the name of

COREY DANIELLE KIMBROUGH and JOSEPH A KIMBROUGH and COYA DENISE KIMBROUGH

Unless said certificate shall be redeemed according to law, the property described therein will be sold to the highest bidder at public auction at 9:00 A.M. on the first Tuesday in the month of September, which is the 2nd day of September 2014.

Dated this 31st day of July 2014.

In accordance with the AMERICANS WITH DISABILITIES ACT, if you are a person with a disability who needs special accommodation in order to participate in this proceeding you are entitled to the provision of certain assistance. Please contact Emily Hogg not later than seven days prior to the proceeding at Escambia County Government Complex, 221 Palafox Place Ste 110, Pensacola FL 32502. Telephone: 850-595-3793.

Post Property:

1111 HOPE DR 32534



PAM CHILDERS
CLERK OF THE CIRCUIT COURT
ESCAMBIA COUNTY, FLORIDA

By:
Emily Hogg
Deputy Clerk

WARNING

THERE ARE UNPAID TAXES ON PROPERTY WHICH YOU OWN OR IN WHICH YOU HAVE A LEGAL INTEREST. THE PROPERTY WILL BE SOLD AT PUBLIC AUCTION ON September 2, 2014, UNLESS THE TAXES ARE PAID. SHOULD YOU NEED FURTHER INFORMATION CONTACT THE CLERK OF THE CIRCUIT COURT IMMEDIATELY AT THE COUNTY COURTHOUSE IN PENSACOLA, FLORIDA, OR CALL 850-595-3793.

NOTICE OF APPLICATION FOR TAX DEED

NOTICE IS HEREBY GIVEN, That **PPF HOLDINGS III LTD** holder of Tax Certificate No. **01638**, issued the **1st** day of **June, A.D., 2012** has filed same in my office and has made application for a tax deed to be issued thereon. Said certificate embraces the following described property in the County of Escambia, State of Florida, to wit:

BEG AT NE COR OF SEC W ALG N LI OF SEC 457 84/100 FT SLY 89 DEG 56 MIN 30 SEC LEFT 39 90/100 FT TO INTER OF S R/W LI OF HOPE DR (66 FT R/W) AND E R/W LI OF BAKER LANE (50 FT R/W) FOR POB CONT S ALG E R/W LI OF BAKER LANE 125 FT E 90 DEG 6 MIN 40 SEC LEFT 144 78/100 FT N 89 DEG 58 MIN 30 SEC LEFT 125 FT TO S R/W LI OF HOPE DR W ALG S LI OF HOPE DR 144 59/100 FT TO POB OR 6343 P 38

SECTION 26, TOWNSHIP 1 S, RANGE 30 W

TAX ACCOUNT NUMBER 030900001 (14-588)

The assessment of the said property under the said certificate issued was in the name of

COREY DANIELLE KIMBROUGH and JOSEPH A KIMBROUGH and COYA DENISE KIMBROUGH

Unless said certificate shall be redeemed according to law, the property described therein will be sold to the highest bidder at public auction at 9:00 A.M. on the **first** Tuesday in the month of September, which is the **2nd** day of September 2014.

Dated this 31st day of July 2014.

In accordance with the AMERICANS WITH DISABILITIES ACT, if you are a person with a disability who needs special accommodation in order to participate in this proceeding you are entitled to the provision of certain assistance. Please contact Emily Hogg not later than seven days prior to the proceeding at Escambia County Government Complex, 221 Palafox Place Ste 110, Pensacola FL 32502. Telephone: 850-595-3793.

Personal Services:

COREY DANIELLE KIMBROUGH
1111 HOPE DR
PENSACOLA, FL 32534

PAM CHILDERS
CLERK OF THE CIRCUIT COURT
ESCAMBIA COUNTY, FLORIDA



By:
Emily Hogg
Deputy Clerk

WARNING

THERE ARE UNPAID TAXES ON PROPERTY WHICH YOU OWN OR IN WHICH YOU HAVE A LEGAL INTEREST. THE PROPERTY WILL BE SOLD AT PUBLIC AUCTION ON September 2, 2014, UNLESS THE TAXES ARE PAID. SHOULD YOU NEED FURTHER INFORMATION CONTACT THE CLERK OF THE CIRCUIT COURT IMMEDIATELY AT THE COUNTY COURTHOUSE IN PENSACOLA, FLORIDA, OR CALL 850-595-3793.

NOTICE OF APPLICATION FOR TAX DEED

NOTICE IS HEREBY GIVEN, That **PPF HOLDINGS III LTD** holder of Tax Certificate No. **01638**, issued the 1st day of **June, A.D., 2012** has filed same in my office and has made application for a tax deed to be issued thereon. Said certificate embraces the following described property in the County of Escambia, State of Florida, to wit:

BEG AT NE COR OF SEC W ALG N LI OF SEC 457 84/100 FT SLY 89 DEG 56 MIN 30 SEC LEFT 39 90/100 FT TO INTER OF S R/W LI OF HOPE DR (66 FT R/W) AND E R/W LI OF BAKER LANE (50 FT R/W) FOR POB CONT S ALG E R/W LI OF BAKER LANE 125 FT E 90 DEG 6 MIN 40 SEC LEFT 144 78/100 FT N 89 DEG 58 MIN 30 SEC LEFT 125 FT TO S R/W LI OF HOPE DR W ALG S LI OF HOPE DR 144 59/100 FT TO POB OR 6343 P 38

SECTION 26, TOWNSHIP 1 S, RANGE 30 W

TAX ACCOUNT NUMBER 030900001 (14-588)

The assessment of the said property under the said certificate issued was in the name of

COREY DANIELLE KIMBROUGH and JOSEPH A KIMBROUGH and COYA DENISE KIMBROUGH

Unless said certificate shall be redeemed according to law, the property described therein will be sold to the highest bidder at public auction at 9:00 A.M. on the **first** Tuesday in the month of September, which is the **2nd** day of September 2014.

Dated this 31st day of July 2014.

In accordance with the AMERICANS WITH DISABILITIES ACT, if you are a person with a disability who needs special accommodation in order to participate in this proceeding you are entitled to the provision of certain assistance. Please contact Emily Hogg not later than seven days prior to the proceeding at Escambia County Government Complex, 221 Palafox Place Ste 110, Pensacola FL 32502. Telephone: 850-595-3793.

Personal Services:

JOSEPH A KIMBROUGH
1111 HOPE DR
PENSACOLA, FL 32534

PAM CHILDERS
CLERK OF THE CIRCUIT COURT
ESCAMBIA COUNTY, FLORIDA



By:
Emily Hogg
Deputy Clerk

WARNING

THERE ARE UNPAID TAXES ON PROPERTY WHICH YOU OWN OR IN WHICH YOU HAVE A LEGAL INTEREST. THE PROPERTY WILL BE SOLD AT PUBLIC AUCTION ON September 2, 2014, UNLESS THE TAXES ARE PAID. SHOULD YOU NEED FURTHER INFORMATION CONTACT THE CLERK OF THE CIRCUIT COURT IMMEDIATELY AT THE COUNTY COURTHOUSE IN PENSACOLA, FLORIDA, OR CALL 850-595-3793.

NOTICE OF APPLICATION FOR TAX DEED

NOTICE IS HEREBY GIVEN, That PPF HOLDINGS III LTD holder of Tax Certificate No. 01638, issued the 1st day of June, A.D., 2012 has filed same in my office and has made application for a tax deed to be issued thereon. Said certificate embraces the following described property in the County of Escambia, State of Florida, to wit:

BEG AT NE COR OF SEC W ALG N LI OF SEC 457 84/100 FT SLY 89 DEG 56 MIN 30 SEC LEFT 39 90/100 FT TO INTER OF S R/W LI OF HOPE DR (66 FT R/W) AND E R/W LI OF BAKER LANE (50 FT R/W) FOR POB CONT S ALG E R/W LI OF BAKER LANE 125 FT E 90 DEG 6 MIN 40 SEC LEFT 144 78/100 FT N 89 DEG 58 MIN 30 SEC LEFT 125 FT TO S R/W LI OF HOPE DR W ALG S LI OF HOPE DR 144 59/100 FT TO POB OR 6343 P 38

SECTION 26, TOWNSHIP 1 S, RANGE 30 W

TAX ACCOUNT NUMBER 030900001 (14-588)

The assessment of the said property under the said certificate issued was in the name of

COREY DANIELLE KIMBROUGH and JOSEPH A KIMBROUGH and COYA DENISE KIMBROUGH

Unless said certificate shall be redeemed according to law, the property described therein will be sold to the highest bidder at public auction at 9:00 A.M. on the first Tuesday in the month of September, which is the 2nd day of September 2014.

Dated this 31st day of July 2014.

In accordance with the AMERICANS WITH DISABILITIES ACT, if you are a person with a disability who needs special accommodation in order to participate in this proceeding you are entitled to the provision of certain assistance. Please contact Emily Hogg not later than seven days prior to the proceeding at Escambia County Government Complex, 221 Palafox Place Ste 110, Pensacola FL 32502. Telephone: 850-595-3793.

Personal Services:

COYA DENISE KIMBROUGH
1111 HOPE DR
PENSACOLA, FL 32534

PAM CHILDERS
CLERK OF THE CIRCUIT COURT
ESCAMBIA COUNTY, FLORIDA



By:
Emily Hogg
Deputy Clerk

7006 1630 0000 0242 7264

U.S. Postal Service
CERTIFIED MAIL RECEIPT
(Domestic Mail Only; No Insurance Coverage Provided)

For delivery information visit our website at www.usps.com

OFFICIAL USE

Postage	\$.49
Certified Fee	3.30
Return Receipt Fee (Endorsement Required)	2.70
Restricted Delivery Fee (Endorsement Required)	
Total Postage & Fees	\$ 6.49



Sent To: COYA DENISE KIMBROUGH [14-588]
 Street, Apt. or PO Box: 1111 HOPE DR
 City, State: PENSACOLA, FL 32534

PS Form 38 Instructions

7006 1630 0000 0242 7271

U.S. Postal Service
CERTIFIED MAIL RECEIPT
(Domestic Mail Only; No Insurance Coverage Provided)

For delivery information visit our website at www.usps.com

OFFICIAL USE

Postage	\$.49
Certified Fee	3.30
Return Receipt Fee (Endorsement Required)	2.70
Restricted Delivery Fee (Endorsement Required)	
Total Postage & Fees	\$ 6.49

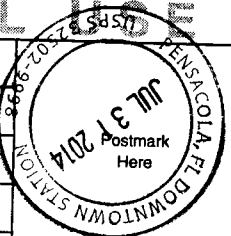

Sent To: DENIQUE C BLACKWELL [14-588]
 Street, Apt. or PO Box: 1323 NORTH J STREET A
 City, State: PENSACOLA FL 32501

PS Form 38 Instructions

7006 1630 0000 0242 7240

U.S. Postal Service
CERTIFIED MAIL RECEIPT
(Domestic Mail Only; No Insurance Coverage Provided)

For delivery information visit our website at www.usps.com

OFFICIAL USE

Postage	\$.49
Certified Fee	3.30
Return Receipt Fee (Endorsement Required)	2.70
Restricted Delivery Fee (Endorsement Required)	
Total Postage & Fees	\$ 6.49

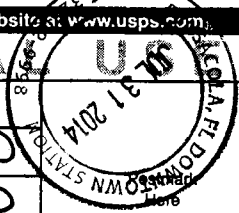

Sent To: COREY DANIELLE KIMBROUGH [14-588]
 Street, Apt. or PO Box: 1111 HOPE DR
 City, State: PENSACOLA, FL 32534

PS Form 38 Instructions

7006 1630 0000 0242 7257

U.S. Postal Service
CERTIFIED MAIL RECEIPT
(Domestic Mail Only; No Insurance Coverage Provided)

For delivery information visit our website at www.usps.com

OFFICIAL USE

Postage	\$.49
Certified Fee	3.30
Return Receipt Fee (Endorsement Required)	2.70
Restricted Delivery Fee (Endorsement Required)	
Total Postage & Fees	\$ 6.49

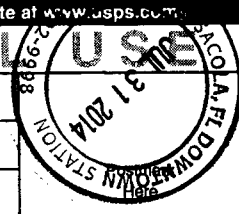

Sent To: JOSEPH A KIMBROUGH [14-588]
 Street, Apt. or PO Box: 1111 HOPE DR
 City, State: PENSACOLA, FL 32534

PS Form 38 Instructions

12/10/14/38

ESCAMBIA COUNTY SHERIFF'S OFFICE
ESCAMBIA COUNTY, FLORIDA

14-588

NON ENFORCEABLE RETURN OF SERVICE

Document Number: ECSO14CIV034137NON

Agency Number: 14-010741

Court: TAX DEED

County: ESCAMBIA

Case Number: CERT NO 01638, 2012

Attorney/Agent:

PAM CHILDERS
CLERK OF COURT
TAX DEED

Plaintiff: RE: COREY DANIELLE KIMBROUGH AND JOSEPH A KIMBROUGH AND COYA DENISE KIMBROUGH
Defendant:

Type of Process: WARNING/NOTICE OF APPLICATION FOR TAX DEED

Received this Writ on 7/31/2014 at 9:50 AM and served same at 8:55 AM on 8/1/2014 in ESCAMBIA COUNTY, FLORIDA,
by serving POST PROPERTY , the within named, to wit: , .

POSTED TO PROPERTY PER INSTRUCTIONS FROM CLERK'S OFFICE.

DAVID MORGAN, SHERIFF
ESCAMBIA COUNTY, FLORIDA

By: 

J. BARTON, CPS

Service Fee: \$40.00
Receipt No: BILL

Printed By: DLRUPERT

WARNING

010741

THERE ARE UNPAID TAXES ON PROPERTY WHICH YOU OWN OR IN WHICH YOU HAVE A LEGAL INTEREST. THE PROPERTY WILL BE SOLD AT PUBLIC AUCTION ON September 2, 2014, UNLESS THE TAXES ARE PAID. SHOULD YOU NEED FURTHER INFORMATION CONTACT THE CLERK OF THE CIRCUIT COURT IMMEDIATELY AT THE COUNTY COURTHOUSE IN PENSACOLA, FLORIDA, OR CALL 850-595-3793.

NOTICE OF APPLICATION FOR TAX DEED

NOTICE IS HEREBY GIVEN, That **PPF HOLDINGS III LTD** holder of **Tax Certificate No. 01638**, issued the **1st** day of **June, A.D., 2012** has filed same in my office and has made application for a tax deed to be issued thereon. Said certificate embraces the following described property in the County of Escambia, State of Florida, to wit:

BEG AT NE COR OF SEC W ALG N LI OF SEC 457 84/100 FT SLY 89 DEG 56 MIN 30 SEC LEFT 39 90/100 FT TO INTER OF S R/W LI OF HOPE DR (66 FT R/W) AND E R/W LI OF BAKER LANE (50 FT R/W) FOR POB CONT S ALG E R/W LI OF BAKER LANE 125 FT E 90 DEG 6 MIN 40 SEC LEFT 144 78/100 FT N 89 DEG 58 MIN 30 SEC LEFT 125 FT TO S R/W LI OF HOPE DR W ALG S LI OF HOPE DR 144 59/100 FT TO POB OR 6343 P 38

SECTION 26, TOWNSHIP 1 S, RANGE 30 W

TAX ACCOUNT NUMBER 030900001 (14-588)

The assessment of the said property under the said certificate issued was in the name of

COREY DANIELLE KIMBROUGH and JOSEPH A KIMBROUGH and COYA DENISE KIMBROUGH

Unless said certificate shall be redeemed according to law, the property described therein will be sold to the highest bidder at public auction at 9:00 A.M. on the **first** Tuesday in the month of September, which is the **2nd** day of September 2014.

Dated this 31st day of July 2014.

In accordance with the AMERICANS WITH DISABILITIES ACT, if you are a person with a disability who needs special accommodation in order to participate in this proceeding you are entitled to the provision of certain assistance. Please contact Emily Hogg not later than seven days prior to the proceeding at Escambia County Government Complex, 221 Palafox Place Ste 110, Pensacola FL 32502. Telephone: 850-595-3793.

Post Property:

1111 HOPE DR 32534



**PAM CHILDERS
CLERK OF THE CIRCUIT COURT
ESCAMBIA COUNTY, FLORIDA**

By:
Emily Hogg
Deputy Clerk

011 JUL 31 A 9:50

030900001

ESCAMBIA COUNTY SHERIFF'S OFFICE
ESCAMBIA COUNTY, FLORIDA

14-588

NON ENFORCEMENT RETURN OF SERVICE

Document Number: ECSO14CIV034078NON

Agency Number: 14-010765

Court: TAX DEED

County: ESCAMBIA

Case Number: CERT NO 01638 2012

Attorney/Agent:

PAM CHILDERS
CLERK OF COURT
TAX DEED

Plaintiff: RE: COREY DANIELLE KIMBROUGH AND JOSEPH A KIMBROUGH AND COYA DENISE KIMBROUGH
Defendant:

Type of Process: NOTICE OF APPLICATION FOR TAX DEED

Substitute

Received this Writ on 7/31/2014 at 9:51 AM and served same on COYA DENISE KIMBROUGH , in ESCAMBIA COUNTY, FLORIDA, at 8:55 AM on 8/1/2014 by leaving a true copy of this Writ together with a copy of the initial pleadings, if any, with the date and hour of service endorsed thereon by me, at the within named individual's usual place of abode, with a person residing therein who is 15 years of age, or older, to wit: FONZEL WILLIAMS, RESIDENT, as a member of the household and informing said person of their contents.

DAVID MORGAN, SHERIFF
ESCAMBIA COUNTY, FLORIDA

By: _____



J. BARTON, CPS

Service Fee: \$40.00

Receipt No: BILL

Printed By: DLRUPERT

WARNING

THERE ARE UNPAID TAXES ON PROPERTY WHICH YOU OWN OR IN WHICH YOU HAVE A LEGAL INTEREST. THE PROPERTY WILL BE SOLD AT PUBLIC AUCTION ON September 2, 2014, UNLESS THE TAXES ARE PAID. SHOULD YOU NEED FURTHER INFORMATION CONTACT THE CLERK OF THE CIRCUIT COURT IMMEDIATELY AT THE COUNTY COURTHOUSE IN PENSACOLA, FLORIDA, OR CALL 850-595-3793.

NOTICE OF APPLICATION FOR TAX DEED

NOTICE IS HEREBY GIVEN, That PPF HOLDINGS III LTD holder of Tax Certificate No. 01638, issued the 1st day of June, A.D., 2012 has filed same in my office and has made application for a tax deed to be issued thereon. Said certificate embraces the following described property in the County of Escambia, State of Florida, to wit:

BEG AT NE COR OF SEC W ALG N LI OF SEC 457 84/100 FT SLY 89 DEG 56 MIN 30 SEC LEFT 39 90/100 FT TO INTER OF S R/W LI OF HOPE DR (66 FT R/W) AND E R/W LI OF BAKER LANE (50 FT R/W) FOR POB CONT S ALG E R/W LI OF BAKER LANE 125 FT E 90 DEG 6 MIN 40 SEC LEFT 144 78/100 FT N 89 DEG 58 MIN 30 SEC LEFT 125 FT TO S R/W LI OF HOPE DR W ALG S LI OF HOPE DR 144 59/100 FT TO POB OR 6343 P 38

SECTION 26, TOWNSHIP 1 S, RANGE 30 W

TAX ACCOUNT NUMBER 030900001 (14-588)

The assessment of the said property under the said certificate issued was in the name of

COREY DANIELLE KIMBROUGH and JOSEPH A KIMBROUGH and COYA DENISE KIMBROUGH

Unless said certificate shall be redeemed according to law, the property described therein will be sold to the highest bidder at public auction at 9:00 A.M. on the first Tuesday in the month of September, which is the 2nd day of September 2014.

Dated this 31st day of July 2014.

In accordance with the AMERICANS WITH DISABILITIES ACT, if you are a person with a disability who needs special accommodation in order to participate in this proceeding you are entitled to the provision of certain assistance. Please contact Emily Hogg not later than seven days prior to the proceeding at Escambia County Government Complex, 221 Palafox Place Ste 110, Pensacola FL 32502. Telephone: 850-595-3793.

Personal Services:

COYA DENISE KIMBROUGH
1111 HOPE DR
PENSACOLA, FL 32534

PAM CHILDERS
CLERK OF THE CIRCUIT COURT
ESCAMBIA COUNTY, FLORIDA



By:
Emily Hogg
Deputy Clerk

EMILY A HOGG
157

ESCAMBIA COUNTY SHERIFF'S OFFICE
ESCAMBIA COUNTY, FLORIDA

14-588

NON ENFORCEABLE RETURN OF SERVICE

Document Number: ECSO14CIV034071NON

Agency Number: 14-010764

Court: TAX DEED

County: ESCAMBIA

Case Number: CERT NO 01638 2012

Attorney/Agent:

PAM CHILDERS
CLERK OF COURT
TAX DEED

Plaintiff: RE: COREY DANIELLE KIMBROUGH AND JOSEPH A KIMBROUGH AND COYA DENISE KIMBROUGH
Defendant:

Type of Process: NOTICE OF APPLICATION FOR TAX DEED

Substitute

Received this Writ on 7/31/2014 at 9:51 AM and served same on JOSEPH A KIMBROUGH , in ESCAMBIA COUNTY, FLORIDA, at 8:55 AM on 8/1/2014 by leaving a true copy of this Writ together with a copy of the initial pleadings, if any, with the date and hour of service endorsed thereon by me, at the within named individual's usual place of abode, with a person residing therein who is 15 years of age, or older, to wit: FONZEL WILLIAMS, RESIDENT, as a member of the household and informing said person of their contents.

DAVID MORGAN, SHERIFF
ESCAMBIA COUNTY, FLORIDA

By: 

J. BARTON, CPS

Service Fee: \$40.00
Receipt No: BILL

Printed By: DLRUPERT

WARNING

010764

THERE ARE UNPAID TAXES ON PROPERTY WHICH YOU OWN OR IN WHICH YOU HAVE A LEGAL INTEREST. THE PROPERTY WILL BE SOLD AT PUBLIC AUCTION ON September 2, 2014, UNLESS THE TAXES ARE PAID. SHOULD YOU NEED FURTHER INFORMATION CONTACT THE CLERK OF THE CIRCUIT COURT IMMEDIATELY AT THE COUNTY COURTHOUSE IN PENSACOLA, FLORIDA, OR CALL 850-595-3793.

NOTICE OF APPLICATION FOR TAX DEED

NOTICE IS HEREBY GIVEN, That PPF HOLDINGS III LTD holder of Tax Certificate No. 01638, issued the 1st day of June, A.D., 2012 has filed same in my office and has made application for a tax deed to be issued thereon. Said certificate embraces the following described property in the County of Escambia, State of Florida, to wit:

BEG AT NE COR OF SEC W ALG N LI OF SEC 457 84/100 FT SLY 89 DEG 56 MIN 30 SEC LEFT 39 90/100 FT TO INTER OF S R/W LI OF HOPE DR (66 FT R/W) AND E R/W LI OF BAKER LANE (50 FT R/W) FOR POB CONT S ALG E R/W LI OF BAKER LANE 125 FT E 90 DEG 6 MIN 40 SEC LEFT 144 78/100 FT N 89 DEG 58 MIN 30 SEC LEFT 125 FT TO S R/W LI OF HOPE DR W ALG S LI OF HOPE DR 144 59/100 FT TO POB OR 6343 P 38

SECTION 26, TOWNSHIP 1 S, RANGE 30 W

TAX ACCOUNT NUMBER 030900001 (14-588)

The assessment of the said property under the said certificate issued was in the name of

COREY DANIELLE KIMBROUGH and JOSEPH A KIMBROUGH and COYA DENISE KIMBROUGH

Unless said certificate shall be redeemed according to law, the property described therein will be sold to the highest bidder at public auction at 9:00 A.M. on the first Tuesday in the month of September, which is the 2nd day of September 2014.

Dated this 31st day of July 2014.

In accordance with the AMERICANS WITH DISABILITIES ACT, if you are a person with a disability who needs special accommodation in order to participate in this proceeding you are entitled to the provision of certain assistance. Please contact Emily Hogg not later than seven days prior to the proceeding at Escambia County Government Complex, 221 Palafox Place Ste 110, Pensacola FL 32502. Telephone: 850-595-3793.

Personal Services:

JOSEPH A KIMBROUGH
1111 HOPE DR
PENSACOLA, FL 32534

PAM CHILDERS
CLERK OF THE CIRCUIT COURT
ESCAMBIA COUNTY, FLORIDA



By:
Emily Hogg
Deputy Clerk

156 V 12 11 1000
A 9 51
10/1/14

ESCAMBIA COUNTY SHERIFF'S OFFICE
ESCAMBIA COUNTY, FLORIDA

14-588

NON ENFORCEABLE RETURN OF SERVICE

Document Number: ECSO14CIV034065NON

Agency Number: 14-010763

Court: TAX DEED

County: ESCAMBIA

Case Number: CERT NO 01638 2012

Attorney/Agent:

PAM CHILDERS
CLERK OF COURT
TAX DEED

Plaintiff: RE: COREY DANIELLE KIMBROUGH AND JOSEPH A KIMBROUGH AND COYA DENISE KIMBROUGH
Defendant:

Type of Process: NOTICE OF APPLICATION FOR TAX DEED

Substitute

Received this Writ on 7/31/2014 at 9:51 AM and served same on COREY DANIELLE KIMBROUGH , in ESCAMBIA COUNTY, FLORIDA, at 8:55 AM on 8/1/2014 by leaving a true copy of this Writ together with a copy of the initial pleadings, if any, with the date and hour of service endorsed thereon by me, at the within named individual's usual place of abode, with a person residing therein who is 15 years of age, or older, to wit: FONZEL WILLIAMS, RESIDENT, as a member of the household and informing said person of their contents.

DAVID MORGAN, SHERIFF
ESCAMBIA COUNTY, FLORIDA

By: 

J. BARTON, CPS

Service Fee: \$40.00
Receipt No: BILL

Printed By: DLRUPERT

WARNING

THERE ARE UNPAID TAXES ON PROPERTY WHICH YOU OWN OR IN WHICH YOU HAVE A LEGAL INTEREST. THE PROPERTY WILL BE SOLD AT PUBLIC AUCTION ON September 2, 2014, UNLESS THE TAXES ARE PAID. SHOULD YOU NEED FURTHER INFORMATION CONTACT THE CLERK OF THE CIRCUIT COURT IMMEDIATELY AT THE COUNTY COURTHOUSE IN PENSACOLA, FLORIDA, OR CALL 850-595-3793.

NOTICE OF APPLICATION FOR TAX DEED

NOTICE IS HEREBY GIVEN, That **PPF HOLDINGS III LTD** holder of **Tax Certificate No. 01638**, issued the 1st day of **June, A.D., 2012** has filed same in my office and has made application for a tax deed to be issued thereon. Said certificate embraces the following described property in the County of Escambia, State of Florida, to wit:

BEG AT NE COR OF SEC W ALG N LI OF SEC 457 84/100 FT SLY 89 DEG 56 MIN 30 SEC LEFT 39 90/100 FT TO INTER OF S R/W LI OF HOPE DR (66 FT R/W) AND E R/W LI OF BAKER LANE (50 FT R/W) FOR POB CONT S ALG E R/W LI OF BAKER LANE 125 FT E 90 DEG 6 MIN 40 SEC LEFT 144 78/100 FT N 89 DEG 58 MIN 30 SEC LEFT 125 FT TO S R/W LI OF HOPE DR W ALG S LI OF HOPE DR 144 59/100 FT TO POB OR 6343 P 38

SECTION 26, TOWNSHIP 1 S, RANGE 30 W

TAX ACCOUNT NUMBER 030900001 (14-588)

The assessment of the said property under the said certificate issued was in the name of

COREY DANIELLE KIMBROUGH and JOSEPH A KIMBROUGH and COYA DENISE KIMBROUGH

Unless said certificate shall be redeemed according to law, the property described therein will be sold to the highest bidder at public auction at 9:00 A.M. on the **first** Tuesday in the month of September, which is the **2nd** day of September 2014.

Dated this 31st day of July 2014.

In accordance with the AMERICANS WITH DISABILITIES ACT, if you are a person with a disability who needs special accommodation in order to participate in this proceeding you are entitled to the provision of certain assistance. Please contact Emily Hogg not later than seven days prior to the proceeding at Escambia County Government Complex, 221 Palafox Place Ste 110, Pensacola FL 32502. Telephone: 850-595-3793.

Personal Services:

COREY DANIELLE KIMBROUGH
1111 HOPE DR
PENSACOLA, FL 32534

PAM CHILDERS
CLERK OF THE CIRCUIT COURT
ESCAMBIA COUNTY, FLORIDA



By:
Emily Hogg
Deputy Clerk

EMILY HOGG
A 9:51
Clerk

VERIFIED MAIL™

PAM CHILDERS
CLERK OF THE CIRCUIT COURT & C
OFFICIAL RECORDS DIVI:

221 Palafox Place
P.O. Box 333
Pensacola, FL 32591-0333



7008 1830 0000 0242 727J

neopost
07/01/2014

US POSTAGE

\$06.48



70 32501
04/11/2014

DENIQUE C BLACKWELL #14 5001

1323 NORTH J STREI
PENSACOLA FL 32:

* 322 DE 1009N C7208/04/14
UNABLE TO FORWARD/FOR REVIEW
C014

CC: 32591227623 DU *2007-05980-01-00

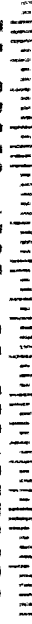

12/1/08