

TAX COLLECTOR'S CERTIFICATION

**Application
Date / Number
Jul 28, 2013 / 130562**

This is to certify that the holder listed below of Tax Sale Certificate Number **2011 / 9080.0000** , issued the **1st** day of **June, 2011**, and which encumbers the following described property located in the County of Escambia, State of Florida to wit: **Parcel ID Number: 11-4134-000**

Certificate Holder:
US BANK, AS C/F FL DUNDEE LIEN
LOCKBOX # 005191
PO BOX 645191
CINCINNATI, OHIO 45264

Property Owner:
MILSTEAD CHRISTOPHER S
1795 MUSCOGEE RD
CANTONMENT , FLORIDA 32533-9153

Legal Description: 18-1N3-132
BEG AT SW COR OF NW 1/4 OF SW 1/4 FOR POB S 89 DEG 39 MIN 34 SEC E ALG S LI 110 FT N 0 DEG 42 MIN 59 SEC W 243 58/100 FT TO SLY R/W LI OF MUSCOGEE RD ...
See attachment for full legal description.

has surrendered same in my office and made written application for tax deed in accordance with Florida Statutes. I certify that the following tax certificates, interest, ownership and encumbrance report fee, and Tax Collector's fees have been paid:

CERTIFICATES OWNED BY APPLICANT AND FILED IN CONNECTION WITH THIS TAX DEED APPLICATION:

Cert. Year	Certificate Number	Date of Sale	Face Amt	T/C Fee	Interest	Total
2011	9080.0000	06/01/11	\$180.59	\$0.00	\$70.43	\$251.02

CERTIFICATES REDEEMED BY APPLICANT OR INCLUDED (COUNTY) IN CONNECTION WITH THIS APPLICATION:

Cert. Year	Certificate Number	Date of Sale	Face Amt	T/C Fee	Interest	Total
2013	8000.0000	06/01/13	\$199.53	\$6.25	\$9.98	\$215.76
2012	8600.0000	06/01/12	\$188.56	\$6.25	\$39.60	\$234.41
2010	9281	06/01/10	\$441.14	\$6.25	\$237.48	\$684.87

1. Total of all Certificates in Applicant's Possession and Cost of the Certificates Redeemed by Applicant or Included (County)
2. Total of Delinquent Taxes Paid by Tax Deed Application
3. Total of Current Taxes Paid by Tax Deed Applicant
4. Ownership and Encumbrance Report Fee
5. Tax Deed Application Fee
6. Total Certified by Tax Collector to Clerk of Court
7. Clerk of Court Statutory Fee
8. Clerk of Court Certified Mail Charge
9. Clerk of Court Advertising Charge
10. Sheriff's Fee
11. _____
12. Total of Lines 6 thru 11
13. Interest Computed by Clerk of Court Per Florida Statutes.....(%)
14. One-Half of the assessed value of homestead property. If applicable pursuant to section 197.502, F.S.
15. Statutory (Opening) Bid; Total of Lines 12 thru 14
16. Redemption Fee
17. Total Amount to Redeem

\$1,386.06
\$0.00
\$150.00
\$75.00
\$1,611.06
\$1,611.06
\$8,127.50
\$6.25

*Done this 28th day of July, 2013

TAX COLLECTOR, ESCAMBIA COUNTY, FLORIDA

By  _____

Date of Sale: 4/7/14

* This certification must be surrendered to the Clerk of the Circuit Court no later than ten days after this date.

FULL LEGAL DESCRIPTION
Parcel ID Number: 11-4134-000

August 12, 2013
Tax Year: 2010
Certificate Number: 9080.0000

BEG AT SW COR OF NW 1/4 OF SW 1/4 FOR POB S 89 DEG 39 MIN 34 SEC E ALG S LI 110 FT N 0 DEG 42 MIN 59 SEC W 243 58/100 FT TO SLY R/W LI OF MUSCOGEE RD SW ALG R/W TO W LI OF SEC S ALG W LI TO POB OR 6536 P 1836

Notice to Tax Collector of Application for Tax Deed

TO: Tax Collector of Escambia County

In accordance with Florida Statutes, I,

**US BANK, AS C/F FL DUNDEE LIEN
LOCKBOX # 005191
PO BOX 645191
CINCINNATI, Ohio, 45264**

holder of the following tax sale certificate hereby surrender same to the Tax Collector and make tax deed application thereon:

Certificate No.	Parcel ID Number	Date	Legal Description
9080.0000	11-4134-000	06/01/2011	18-1N3-132 BEG AT SW COR OF NW 1/4 OF SW 1/4 FOR POB S 89 DEG 39 MIN 34 SEC E ALG S LI 110 FT N 0 DEG 42 MIN 59 SEC W 243 58/100 FT TO SLY R/W LI OF MUSCOGEE RD SW ALG R/W TO W LI OF SEC S ALG W LI TO POB OR 6536 P 1836

2012 TAX ROLL

MILSTEAD CHRISTOPHER S
1795 MUSCOGEE RD
CANTONMENT , Florida 32533-9153

I agree to pay all delinquent taxes, redeem all outstanding certificates not in my possession, pay any omitted taxes, and pay current taxes, if due, covering the land, and pay any interest earned (a) on tax certificates not in my possession, (b) on omitted taxes or (c) on delinquent taxes. I also agree to pay all Tax Collector's fees, ownership and encumbrance reports costs, Clerk of the Court costs, charges and fees and Sheriff's costs, if applicable. Attached is the above-mentioned tax sale certificate on which this application is based and all other certificates of the same legal description which are in my possession.

glfunl (Jacob Prince)
Applicant's Signature

07/28/2013
Date

Southern Guaranty Title Company

4400 Bayou Boulevard, Suite 13B

Pensacola, Florida 32503

Telephone: 850-478-8121

Facsimile: 850-476-1437

OWNERSHIP AND ENCUMBRANCE REPORT

File No.: 10787

September 18, 2013

Escambia County Tax Collector

P.O. Box 1312

Pensacola, Florida 32569

Pursuant to your request, the Company has caused a search to be made of the Public Records of Escambia County, Florida, solely as revealed by records maintained from 09-18-1993, through 09-18-2013, and said search reveals the following:

1. THE GRANTEE(S) OF THE LAST DEED(S) OF RECORD IS:

Christopher S. Milstead

2. The land covered by this Report is:

LEGAL DESCRIPTION IS ATTACHED HERETO AND MADE A PART HEREOF

3. The following unsatisfied mortgages, liens and judgments affecting the land covered by this Report appear of record:

SEE CONTINUATION PAGE ATTACHED HERETO AND MADE A PART HEREOF

4. Taxes:

SEE CONTINUATION PAGE ATTACHED HERETO AND MADE A PART HEREOF

The foregoing report is prepared and furnished for information only, is not intended to constitute or imply any opinion, warranty, guaranty, insurance, or similar assurance as to the status of title, and no determination has been made of the authenticity of any instrument described or referred to herein. The name search for the purposes of determining applicable judgments and liens is limited to the apparent record owner(s) shown herein, No attempt has been made to determine whether the land is subject to liens or assessments which are not shown as existing liens by the public records. The Company's liability hereunder shall not exceed the cost of this Report, or \$1,000.00 whichever is less.

THIS REPORT SHALL NOT BE USED FOR THE ISSUANCE OF TITLE INSURANCE.

Southern Guaranty Title Company

By: 

September 18, 2013

**OWNERSHIP AND ENCUMBRANCE REPORT
LEGAL DESCRIPTION**

File No.: 10787

September 18, 2013

181N313203000001 - Full Legal Description

BEG AT SW COR OF NW 1/4 OF SW 1/4 FOR POB S 89 DEG 39 MIN 34 SEC E ALG S LI 110 FT N 0 DEG 42 MIN 59 SEC W 243 58/100 FT TO SLY R/W LI OF MUSCOGEE RD SW ALG R/W TO W LI OF SEC S ALG W LI TO POB OR 6536 P 1836

**OWNERSHIP AND ENCUMBRANCE REPORT
CONTINUATION PAGE**

File No.: 10787

September 18, 2013

UNSATISFIED MORTGAGES, LIENS AND JUDGMENTS AFFECTING THE LAND COVERED BY THIS REPORT THAT APPEAR OF RECORD:

1. Utility Lien filed by ECUA recorded in O.R. Book 6927, page 1424.
2. Taxes for the year 2009-2012 delinquent. The assessed value is \$16,304.00. Tax ID 11-4134-000.

PLEASE NOTE THE FOLLOWING:

- A. Subject to current year taxes.
- B. Taxes and assessments due now or in subsequent years.
- C. Subject to Easements, Restrictions and Covenants of record.
- D. Encroachments, overlaps, boundary line disputes, and any other matters which would be disclosed by an accurate survey and inspection of the premises.
- E. Oil, gas and mineral or any other subsurface rights of any kind or nature.

SOUTHERN GUARANTY TITLE COMPANY

4400 BAYOU BLVD., SUITE 13-B, CORDOVA SQUARE

PENSACOLA, FLORIDA 32503

TEL. (850) 478-8121 FAX (850) 476-1437

Email: rcsgt@aol.com

Janet Holley
Escambia County Tax Collector
P.O. Box 1312
Pensacola, FL 32596

CERTIFICATION: TITLE SEARCH FOR TDA

TAX DEED SALE DATE: 04-07-2014

TAX ACCOUNT NO.: 11-4134-000

CERTIFICATE NO.: 2011-9080

In compliance with Section 197.256, Florida Statutes, the following is a list of names and addresses of those persons, firms and/or agencies having legal interest in or claim against the above described property. The above referenced tax sale certificate is being submitted as proper notification of tax deed sale.

YES NO

Notify City of Pensacola, P.O. Box 12910, 32521

Notify Escambia County, 190 Governmental Center, 32502

Homestead for 2012 tax year.

Christopher S. Milstead
1795 Muscogee Rd.
Cantonment, FL 32533

ECUA
9255 Sturdevant St.
Pensacola, FL 32514

Certified and delivered to Escambia County Tax Collector,
this 19th day of September, 2013.

SOUTHERN GUARANTY TITLE COMPANY

by: Richard S. Combs, President

NOTE: The above listed addresses are based upon current information available, but said addresses are not guaranteed to be true or correct.

This instrument prepared by:
Raymond B. Palmer, Esquire
Law Office of Raymond B. Palmer, P.A.
913 Gulf Breeze Parkway, Suite 41
Gulf Breeze, FL 32561
Voice: 850-916-1000
Fax: 850-916-0080

Tax Parcel ID: 181N313203000001

Warranty Deed
(Statutory Form - FS 689.02)

This Indenture, made this 30 of October, 2009, between **Betty Ann Clements Hahn also known as Betty Ann Clements**, a married woman, of the County of Cleveland in the State of Arkansas, whose post address is 287 Copeland Cave Road, Cleveland, Arkansas 72030, party of the first part, and **Christopher Shane Milstead**, party of the second part, and whose post office address 1795 Muscogee Road, Cantonment, FL 32533,

Witnesseth:

That the said party of the first part, for and in consideration of the sum of \$10.00 and other valuable consideration, to him in hand paid by the said party of the second part, the receipt whereof is hereby acknowledged, has granted, bargained and sold to the said party of the second part, his heirs and assigns forever, the following described land, to wit:

The West 110 feet of the Northwest Quarter of the Southwest Quarter, Section 18, Township 1 North, Range 31 West, Escambia County, Florida, lying South of the Muscogee-Cantonment Road.

SUBJECT TO EASEMENTS, RESTRICTIONS AND RESERVATIONS OF RECORD NOT COUPLED WITH A RIGHT OF REVERTER AND TAXES FOR THE CURRENT YEAR.

Party of the first part, **Betty Ann Clements Hahn**, Grantor, hereby attests that the subject property is not now and has never been Grantors' constitutional homestead. Grantor resides at 287 Copeland Cave Road, Cleveland, Arkansas 72030.

And the said party of the first part does hereby fully warrant the title to said land, and will defend the same against the lawful claims of all persons whomsoever.

Signed, sealed and delivered in the presence of:

Susan Gunderman
Witness: Susan Gunderman

Betty Ann Clements Hahn
Betty Ann Clements Hahn

Brigitte Brents
Witness: Brigitte Brents

STATE OF Arkansas }
COUNTY OF Conway }

ACKNOWLEDGMENT

The foregoing instrument was acknowledged before me this 30 October, 2009, by Betty Ann Clements Hahn, who is personally known to me or who produced a driver's license as identification and who did not take an oath.

NOTARY PUBLIC:

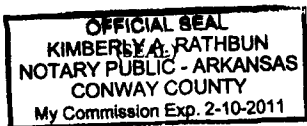

Kimberley A Rathbun
Kimberly A Rathbun
NOTARY PRINT NAME:

My commission expires: 02-10-2011

This Instrument Was Prepared
By And Is To Be Returned To:
B. CAROL MERRITT
Emerald Coast Utilities Authority
9255 Sturdevant Street
Pensacola, Florida 32514-0311



NOTICE OF LIEN

**STATE OF FLORIDA
COUNTY OF ESCAMBIA**

Notice is hereby given that the EMERALD COAST UTILITES AUTHORITY has a lien against the following described real property situated in Escambia County, Florida, for water, wastewater and/or sanitation service provided to the following customer:

BEG AT SW COR OF NW 1/4 OF SW 1/4 FOR POB S 89 DEG 39 MIN 34 SEC E ALG S LI 110 FT N 0 DEG 42 MIN 59 SEC W...

Customer: CHRISTOPHER S MILSTEAD

Account Number: 335386-137924

Amount of Lien: \$76.50, together with additional unpaid utility service charges, if any, which may accrue subsequent to the date of this notice and simple interest on unpaid charges at 18 percent per annum, or at such lesser rate as may be allowed by law.

This lien is imposed in accordance with Section 159.17, Florida Statutes, Chapter 92-248, Laws of Florida, as amended and Emerald Coast Utilities Authority Resolution 87-10, as amended, and this lien shall be prior to all other liens on such lands or premises except the lien of state, county, and municipal taxes and shall be on a parity with the lien of such state, county, and municipal taxes.

Provided however, that if the above-named customer has conveyed said property by means of deed recorded in the public records of Escambia County, Florida, prior to the recording of this instrument, or if the interest of the above-named customer is foreclosed by a proceeding in which notice of lis pendens has been filed prior to the recording of this instrument, this lien shall be void and of no effect.

Dated: 10/25/12

EMERALD COAST UTILITIES AUTHORITY

BY: B. Carol Merritt

STATE OF FLORIDA
COUNTY OF ESCAMBIA

The foregoing instrument was acknowledged before me this 25 day of OCTOBER, 20 12, by B. CAROL MERRITT of the Emerald Coast Utilities Authority, who is personally known to me and who did not take an oath.

[Notary Seal]

[Signature]
Notary Public - State of Florida

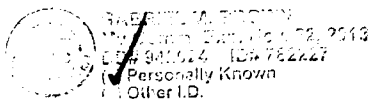

STATE OF FLORIDA
COUNTY OF ESCAMBIA

**CERTIFICATE OF NOTICE OF MAILING
NOTICE OF APPLICATION FOR TAX DEED**

CERTIFICATE # 09080 of 2011

I, PAM CHILDERS, CLERK OF THE CIRCUIT COURT OF ESCAMBIA COUNTY, FLORIDA, do hereby certify that I did on March 6, 2014, mail a copy of the foregoing Notice of Application for Tax Deed, addressed to:

CHRISTOPHER S MILSTEAD 1795 MUSCOGEE RD CANTONMENT, FL 32533-9153	ECUA 9255 STURDEVANT ST PENSACOLA, FL 32514
---	---

WITNESS my official seal this 6th day of March 2014.



PAM CHILDERS
CLERK OF THE CIRCUIT COURT
ESCAMBIA COUNTY, FLORIDA

By:
Emily Hogg
Deputy Clerk

WARNING

THERE ARE UNPAID TAXES ON PROPERTY WHICH YOU OWN OR IN WHICH YOU HAVE A LEGAL INTEREST. THE PROPERTY WILL BE SOLD AT PUBLIC AUCTION ON April 7, 2014, UNLESS THE TAXES ARE PAID. SHOULD YOU NEED FURTHER INFORMATION CONTACT THE CLERK OF THE CIRCUIT COURT IMMEDIATELY AT THE COUNTY COURTHOUSE IN PENSACOLA, FLORIDA, OR CALL 850-595-3793.

NOTICE OF APPLICATION FOR TAX DEED

NOTICE IS HEREBY GIVEN, That US BANK AS C/F FL DUNDEE LIEN holder of Tax Certificate No. 09080, issued the 1st day of June, A.D., 2011 has filed same in my office and has made application for a tax deed to be issued thereon. Said certificate embraces the following described property in the County of Escambia, State of Florida, to wit:

BEG AT SW COR OF NW 1/4 OF SW 1/4 FOR POB S 89 DEG 39 MIN 34 SEC E ALG S LI 110 FT N 0 DEG 42 MIN 59 SEC W 243 58/100 FT TO SLY R/W LI OF MUSCOGEE RD SW ALG R/W TO W LI OF SEC S ALG W LI TO POB OR 6536 P 1836

SECTION 18, TOWNSHIP 1 N, RANGE 31 W

TAX ACCOUNT NUMBER 114134000 (14-262)

The assessment of the said property under the said certificate issued was in the name of

CHRISTOPHER S MILSTEAD

Unless said certificate shall be redeemed according to law, the property described therein will be sold to the highest bidder at public auction at 9:00 A.M. on the first Monday in the month of April, which is the 7th day of April 2014.

Dated this 6th day of March 2014.

In accordance with the AMERICANS WITH DISABILITIES ACT, if you are a person with a disability who needs special accommodation in order to participate in this proceeding you are entitled to the provision of certain assistance. Please contact Emily Hogg not later than seven days prior to the proceeding at Escambia County Government Complex, 221 Palafox Place Ste 110, Pensacola FL 32502. Telephone: 850-595-3793.



PAM CHILDERS
CLERK OF THE CIRCUIT COURT
ESCAMBIA COUNTY, FLORIDA

By:
Emily Hogg
Deputy Clerk

WARNING

THERE ARE UNPAID TAXES ON PROPERTY WHICH YOU OWN OR IN WHICH YOU HAVE A LEGAL INTEREST. THE PROPERTY WILL BE SOLD AT PUBLIC AUCTION ON April 7, 2014, UNLESS THE TAXES ARE PAID. SHOULD YOU NEED FURTHER INFORMATION CONTACT THE CLERK OF THE CIRCUIT COURT IMMEDIATELY AT THE COUNTY COURTHOUSE IN PENSACOLA, FLORIDA, OR CALL 850-595-3793.

NOTICE OF APPLICATION FOR TAX DEED

NOTICE IS HEREBY GIVEN, That US BANK AS C/F FL DUNDEE LIEN holder of Tax Certificate No. 09080, issued the 1st day of June, A.D., 2011 has filed same in my office and has made application for a tax deed to be issued thereon. Said certificate embraces the following described property in the County of Escambia, State of Florida, to wit:

BEG AT SW COR OF NW 1/4 OF SW 1/4 FOR POB S 89 DEG 39 MIN 34 SEC E ALG S LI 110 FT N 0 DEG 42 MIN 59 SEC W 243 58/100 FT TO SLY R/W LI OF MUSCOGEE RD SW ALG R/W TO W LI OF SEC S ALG W LI TO POB OR 6536 P 1836

SECTION 18, TOWNSHIP 1 N, RANGE 31 W

TAX ACCOUNT NUMBER 114134000 (14-262)

The assessment of the said property under the said certificate issued was in the name of

CHRISTOPHER S MILSTEAD

Unless said certificate shall be redeemed according to law, the property described therein will be sold to the highest bidder at public auction at 9:00 A.M. on the first Monday in the month of April, which is the 7th day of April 2014.

Dated this 6th day of March 2014.

In accordance with the AMERICANS WITH DISABILITIES ACT, if you are a person with a disability who needs special accommodation in order to participate in this proceeding you are entitled to the provision of certain assistance. Please contact Emily Hogg not later than seven days prior to the proceeding at Escambia County Government Complex, 221 Palafox Place Ste 110, Pensacola FL 32502. Telephone: 850-595-3793.

Post Property:

1799 MUSCOGEE RD 32533



PAM CHILDERS
CLERK OF THE CIRCUIT COURT
ESCAMBIA COUNTY, FLORIDA

By:
Emily Hogg
Deputy Clerk

WARNING

THERE ARE UNPAID TAXES ON PROPERTY WHICH YOU OWN OR IN WHICH YOU HAVE A LEGAL INTEREST. THE PROPERTY WILL BE SOLD AT PUBLIC AUCTION ON April 7, 2014, UNLESS THE TAXES ARE PAID. SHOULD YOU NEED FURTHER INFORMATION CONTACT THE CLERK OF THE CIRCUIT COURT IMMEDIATELY AT THE COUNTY COURTHOUSE IN PENSACOLA, FLORIDA, OR CALL 850-595-3793.

NOTICE OF APPLICATION FOR TAX DEED

NOTICE IS HEREBY GIVEN, That US BANK AS C/F FL DUNDEE LIEN holder of Tax Certificate No. 09080, issued the 1st day of June, A.D., 2011 has filed same in my office and has made application for a tax deed to be issued thereon. Said certificate embraces the following described property in the County of Escambia, State of Florida, to wit:

BEG AT SW COR OF NW 1/4 OF SW 1/4 FOR POB S 89 DEG 39 MIN 34 SEC E ALG S LI 110 FT N 0 DEG 42 MIN 59 SEC W 243 58/100 FT TO SLY R/W LI OF MUSCOGEE RD SW ALG R/W TO W LI OF SEC S ALG W LI TO POB OR 6536 P 1836

SECTION 18, TOWNSHIP 1 N, RANGE 31 W

TAX ACCOUNT NUMBER 114134000 (14-262)

The assessment of the said property under the said certificate issued was in the name of

CHRISTOPHER S MILSTEAD

Unless said certificate shall be redeemed according to law, the property described therein will be sold to the highest bidder at public auction at 9:00 A.M. on the **first Monday** in the month of April, which is the **7th day of April 2014**.

Dated this 6th day of March 2014.

In accordance with the AMERICANS WITH DISABILITIES ACT, if you are a person with a disability who needs special accommodation in order to participate in this proceeding you are entitled to the provision of certain assistance. Please contact Emily Hogg not later than seven days prior to the proceeding at Escambia County Government Complex, 221 Palafox Place Ste 110, Pensacola FL 32502. Telephone: 850-595-3793.

Personal Services:

CHRISTOPHER S MILSTEAD
1795 MUSCOGEE RD
CANTONMENT, FL 32533-9153

PAM CHILDERS
CLERK OF THE CIRCUIT COURT
ESCAMBIA COUNTY, FLORIDA

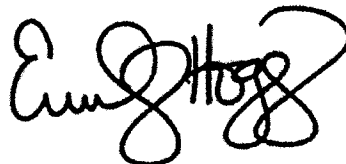

By:
Emily Hogg
Deputy Clerk

11/9080

7008 1830 0000 0238 4475

U.S. Postal Service
CERTIFIED MAIL RECEIPT
(Domestic Mail Only; No Insurance Coverage Provided)

For delivery information visit our website at www.usps.com.

OFFICIAL RECEIPT

Postage	\$ 0.49
Certified Fee	3.30
Return Receipt Fee (Endorsement Required)	2.70
Restricted Delivery Fee (Endorsement Required)	
Total Postage & Fees	\$ 6.49

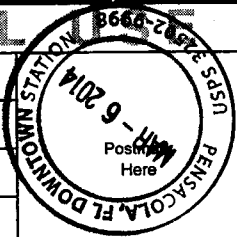

Sent To
CHRISTOPHER S MILSTEAD [14-262]
Street, Apt or PO Box
1795 MUSCOGEE RD
City, State
CANTONMENT, FL 32533-9153

PS Form Instructions

7008 1830 0000 0238 4482

U.S. Postal Service
CERTIFIED MAIL RECEIPT
(Domestic Mail Only; No Insurance Coverage Provided)

For delivery information visit our website at www.usps.com.

OFFICIAL RECEIPT

Postage	\$ 0.49
Certified Fee	3.30
Return Receipt Fee (Endorsement Required)	2.70
Restricted Delivery Fee (Endorsement Required)	
Total Postage & Fees	\$ 6.49

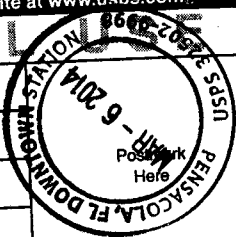

Sent To
ECUA [14-262]
Street, Apt or PO Box
9255 STURDEVANT ST
City, State
PENSACOLA, FL 32514

PS Form Instructions

W/9080

SENDER: COMPLETE THIS SECTION

- Complete items 1, 2, and 3. Also complete item 4 if Restricted Delivery is desired.
- Print your name and address on the reverse so that we can return the card to you.
- Attach this card to the back of the mailpiece, or on the front if space permits.

1. Article Addressed to:

ECUA [14-262]
 9255 STURDEVANT ST
 PENSACOLA, FL 32514

COMPLETE THIS SECTION ON DELIVERY

A. Signature Agent
 Addressee

B. Received by (Printed Name) Date of Delivery
 Randall Frankum 3-7-14

D. Is delivery address different from item 1? Yes
 If YES, enter delivery address below: No

3. Service Type
 Certified Mail Express Mail
 Registered Return Receipt for Merchandise
 Insured Mail C.O.D.

4. Restricted Delivery? (Extra Fee) Yes

2. Article Number
 (Transfer from service label)

7008 1830 0000 0238 4482

ESCAMBIA COUNTY SHERIFF'S OFFICE
ESCAMBIA COUNTY, FLORIDA

NON-ENFORCEABLE RETURN OF SERVICE

14-262

Document Number: ECSO14CIV010708NON

Agency Number: 14-005653

Court: TAX DEED

County: ESCAMBIA

Case Number: CERT NO 09080 2011

Attorney/Agent:

PAM CHILDERS
CLERK OF COURT
TAX DEED

Plaintiff: RE: CHRISTOPHER S MILSTEAD

Defendant:

Type of Process: NOTICE OF APPLICATION FOR TAX DEED

Received this Writ on 3/6/2014 at 4:09 PM and served same at 8:48 AM on 3/13/2014 in ESCAMBIA COUNTY, FLORIDA, by serving POST PROPERTY , the within named, to wit: , .

POSTED TO PROPERTY PER INSTRUCTIONS FROM CLERK'S OFFICE.

DAVID MORGAN, SHERIFF
ESCAMBIA COUNTY, FLORIDA

By: _____

 918
D. BANKS, CPS

Service Fee: \$40.00
Receipt No: BILL

Printed By: JLBRYANT

WARNING

THERE ARE UNPAID TAXES ON PROPERTY WHICH YOU OWN OR IN WHICH YOU HAVE A LEGAL INTEREST. THE PROPERTY WILL BE SOLD AT PUBLIC AUCTION ON April 7, 2014, UNLESS THE TAXES ARE PAID. SHOULD YOU NEED FURTHER INFORMATION CONTACT THE CLERK OF THE CIRCUIT COURT IMMEDIATELY AT THE COUNTY COURTHOUSE IN PENSACOLA, FLORIDA, OR CALL 850-595-3793.

NOTICE OF APPLICATION FOR TAX DEED

NOTICE IS HEREBY GIVEN, That US BANK AS C/F FL DUNDEE LIEN holder of Tax Certificate No. 09080, issued the 1st day of June, A.D., 2011 has filed same in my office and has made application for a tax deed to be issued thereon. Said certificate embraces the following described property in the County of Escambia, State of Florida, to wit:

BEG AT SW COR OF NW 1/4 OF SW 1/4 FOR POB S 89 DEG 39 MIN 34 SEC E ALG S LI 110 FT N 0 DEG 42 MIN 59 SEC W 243 58/100 FT TO SLY R/W LI OF MUSCOGEE RD SW ALG R/W TO W LI OF SEC S ALG W LI TO POB OR 6536 P 1836

SECTION 18, TOWNSHIP 1 N, RANGE 31 W

TAX ACCOUNT NUMBER 114134000 (14-262)

The assessment of the said property under the said certificate issued was in the name of

CHRISTOPHER S MILSTEAD

Unless said certificate shall be redeemed according to law, the property described therein will be sold to the highest bidder at public auction at 9:00 A.M. on the first Monday in the month of April, which is the 7th day of April 2014.

Dated this 6th day of March 2014.

In accordance with the AMERICANS WITH DISABILITIES ACT, if you are a person with a disability who needs special accommodation in order to participate in this proceeding you are entitled to the provision of certain assistance. Please contact Emily Hogg not later than seven days prior to the proceeding at Escambia County Government Complex, 221 Palafox Place Ste 110, Pensacola FL 32502. Telephone: 850-595-3793.

Post Property:

1799 MUSCOGEE RD 32533

**PAM CHILDERS
CLERK OF THE CIRCUIT COURT
ESCAMBIA COUNTY, FLORIDA**



By:
Emily Hogg
Deputy Clerk

RECEIVED
MAR 11 2014
10:09 AM

Source: Escambia County Property Appraiser

Navigate Mode
 Account
 Reference

[Restore Full Page Version](#)

<p>General Information</p> <p>Reference: 181N313203000001</p> <p>Account: 114134000</p> <p>Owners: MILSTEAD CHRISTOPHER S</p> <p>Mail: 1795 MUSCOGEE RD CANTONMENT, FL 325339153</p> <p>Situs: 1799 MUSCOGEE RD 32533</p> <p>Use Code: MOBILE HOME</p> <p>Taxing Authority: COUNTY MSTU</p> <p>Tax Inquiry: Open Tax Inquiry Window</p> <p>Tax Inquiry link courtesy of Janet Holley Escambia County Tax Collector</p>	<p>2013 Certified Roll Assessment</p> <p>Improvements: \$6,044</p> <p>Land: \$10,260</p> <p>Total: \$16,304</p> <p>Save Our Homes: \$16,304</p> <p style="text-align: center;">Disclaimer</p> <p style="text-align: center;"><u>Amendment 1/Portability Calculations</u></p>
---	--

<p>Sales Data</p> <table border="1"> <thead> <tr> <th>Sale Date</th> <th>Book</th> <th>Page</th> <th>Value</th> <th>Type</th> <th>Official Records (New Window)</th> </tr> </thead> <tbody> <tr> <td>10/30/2009</td> <td>6536</td> <td>1836</td> <td>\$100</td> <td>WD</td> <td>View Instr</td> </tr> <tr> <td>09/22/2009</td> <td>6510</td> <td>977</td> <td>\$100</td> <td>CJ</td> <td>View Instr</td> </tr> <tr> <td>01/1999</td> <td>4393</td> <td>1816</td> <td>\$100</td> <td>OT</td> <td>View Instr</td> </tr> <tr> <td>12/1979</td> <td>1399</td> <td>341</td> <td>\$100</td> <td>WD</td> <td>View Instr</td> </tr> <tr> <td>01/1976</td> <td>1073</td> <td>561</td> <td>\$100</td> <td>QC</td> <td>View Instr</td> </tr> <tr> <td>01/1976</td> <td>1066</td> <td>972</td> <td>\$100</td> <td>QC</td> <td>View Instr</td> </tr> <tr> <td>01/1968</td> <td>402</td> <td>202</td> <td>\$12,000</td> <td>WD</td> <td>View Instr</td> </tr> </tbody> </table> <p>Official Records Inquiry courtesy of Pam Childers Escambia County Clerk of the Circuit Court and Comptroller</p>	Sale Date	Book	Page	Value	Type	Official Records (New Window)	10/30/2009	6536	1836	\$100	WD	View Instr	09/22/2009	6510	977	\$100	CJ	View Instr	01/1999	4393	1816	\$100	OT	View Instr	12/1979	1399	341	\$100	WD	View Instr	01/1976	1073	561	\$100	QC	View Instr	01/1976	1066	972	\$100	QC	View Instr	01/1968	402	202	\$12,000	WD	View Instr	<p>2013 Certified Roll Exemptions</p> <p>HOMESTEAD EXEMPTION</p> <hr/> <p>Legal Description</p> <p>BEG AT SW COR OF NW 1/4 OF SW 1/4 FOR POB S 89 DEG 39 MIN 34 SEC E ALG S LI 110 FT N 0 DEG 42 MIN 59 SEC W...</p> <hr/> <p>Extra Features</p> <p>METAL BUILDING</p>
Sale Date	Book	Page	Value	Type	Official Records (New Window)																																												
10/30/2009	6536	1836	\$100	WD	View Instr																																												
09/22/2009	6510	977	\$100	CJ	View Instr																																												
01/1999	4393	1816	\$100	OT	View Instr																																												
12/1979	1399	341	\$100	WD	View Instr																																												
01/1976	1073	561	\$100	QC	View Instr																																												
01/1976	1066	972	\$100	QC	View Instr																																												
01/1968	402	202	\$12,000	WD	View Instr																																												

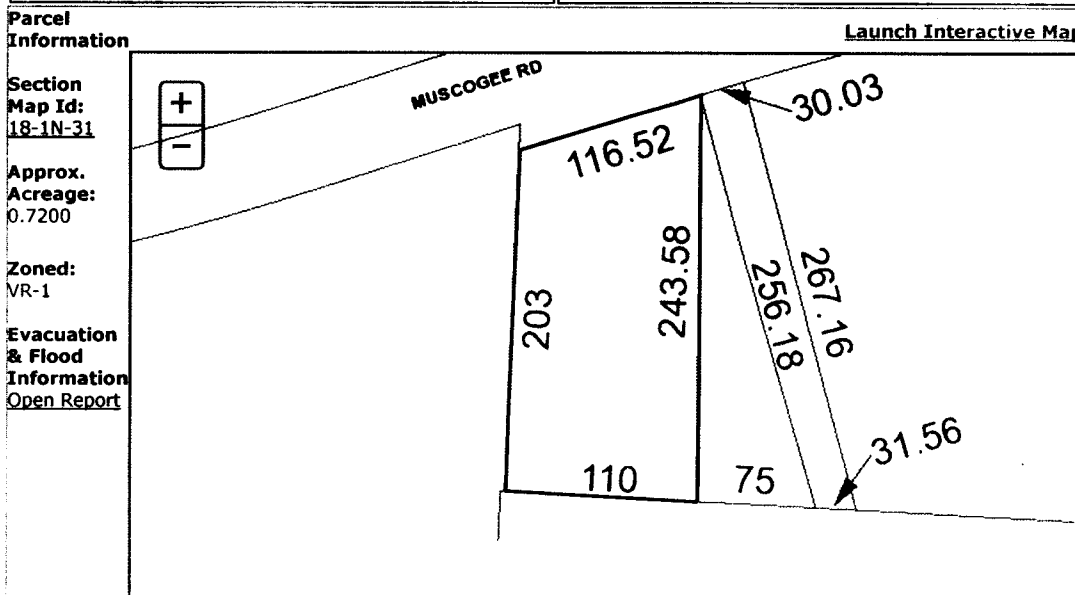

Buildings

Building 1 - Address:1799 MUSCOGEE RD, Year Built: 1977, Effective Year: 1977

Structural Elements
 MH FLOOR SYSTEM-TYPICAL
 MH EXTERIOR WALL-VINYL/METAL
 NO. PLUMBING FIXTURES-6.00
 DWELLING UNITS-1.00
 MH ROOF FRAMING-FLAT/SHED
 MH ROOF COVER-METAL
 MH INTERIOR FINISH-PANEL PLYWOOD
 MH FLOOR FINISH-CARPET
 NO. STORIES-1.00
 MH MILLWORK-TYPICAL
 MH HEAT/AIR-HEAT & AIR
 MH STRUCTURAL FRAME-TYPICAL

Areas - 2620 Total SF
 BASE AREA - 1344
 CARPORT UNF - 336
 GARAGE FIN - 576
 OPEN PORCH FIN - 364

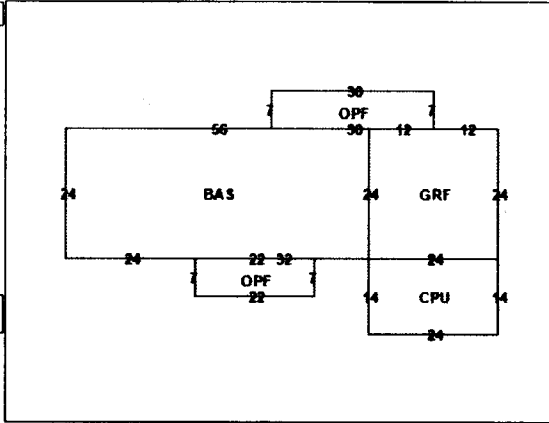

Building 2 - Address:1795 MUSCOGEE RD, Year Built: 1981, Effective Year: 1981

Structural Elements
 MH FLOOR SYSTEM-TYPICAL
 MH EXTERIOR WALL-VINYL/METAL
 NO. PLUMBING FIXTURES-3.00
 DWELLING UNITS-1.00
 MH ROOF FRAMING-GABLE HIP
 MH ROOF COVER-METAL
 MH INTERIOR FINISH-PANEL PLYWOOD
 MH FLOOR FINISH-CARPET
 NO. STORIES-1.00
 MH MILLWORK-TYPICAL
 MH HEAT/AIR-HEAT & AIR
 MH STRUCTURAL FRAME-TYPICAL

Areas - 1036 Total SF
 BASE AREA - 728
 OPEN PORCH FIN - 308

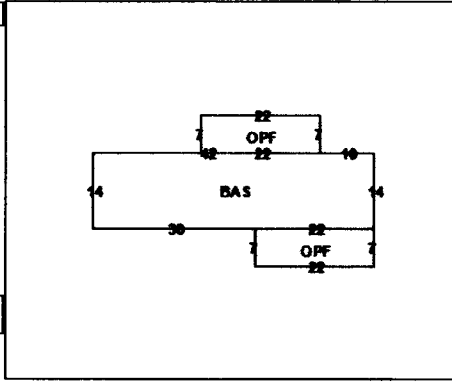

Images



7/22/11



7/22/11

The primary use of the assessment data is for the preparation of the current year tax roll. No responsibility or liability is assumed for inaccuracies or errors.

*3-12-14 torn down
 only a frame on ground*

ESCAMBIA COUNTY SHERIFF'S OFFICE
ESCAMBIA COUNTY, FLORIDA

NON-ENFORCEABLE RETURN OF SERVICE

14-262

Document Number: ECSO14CIV010722NON

Agency Number: 14-005700

Court: TAX DEED

County: ESCAMBIA

Case Number: CERT #09080 2011

Attorney/Agent:

PAM CHILDERS
CLERK OF COURT
TAX DEED

Plaintiff: RE: CHRISTOPHER S MILSTEAD

Defendant:

Type of Process: NOTICE OF APPLICATION FOR TAX DEED

Non-Executed

Received this Writ on 3/6/2014 at 4:18 PM and after a diligent search in ESCAMBIA COUNTY, FLORIDA for CHRISTOPHER S MILSTEAD , Writ was returned to court UNEXECUTED on 3/17/2014 for the following reason:

AFTER SEVERAL ATTEMPTS, UNABLE TO MAKE CONTACT WITH SUBJECT BEFORE SERVE BY DATE.

DAVID MORGAN, SHERIFF
ESCAMBIA COUNTY, FLORIDA

By: _____

R Preston 927

R. PRESTON, CPS

Service Fee: \$40.00
Receipt No: BILL

Printed By: JLBRYANT

WARNING

THERE ARE UNPAID TAXES ON PROPERTY WHICH YOU OWN OR IN WHICH YOU HAVE A LEGAL INTEREST. THE PROPERTY WILL BE SOLD AT PUBLIC AUCTION ON April 7, 2014, UNLESS THE TAXES ARE PAID. SHOULD YOU NEED FURTHER INFORMATION CONTACT THE CLERK OF THE CIRCUIT COURT IMMEDIATELY AT THE COUNTY COURTHOUSE IN PENSACOLA, FLORIDA, OR CALL 850-595-3793.

NOTICE OF APPLICATION FOR TAX DEED

NOTICE IS HEREBY GIVEN, That **US BANK AS C/F FL DUNDEE LIEN** holder of **Tax Certificate No. 09080**, issued the **1st day of June, A.D., 2011** has filed same in my office and has made application for a tax deed to be issued thereon. Said certificate embraces the following described property in the County of Escambia, State of Florida, to wit:

BEG AT SW COR OF NW 1/4 OF SW 1/4 FOR POB S 89 DEG 39 MIN 34 SEC E ALG S LI 110 FT N 0 DEG 42 MIN 59 SEC W 243 58/100 FT TO SLY R/W LI OF MUSCOGEE RD SW ALG R/W TO W LI OF SEC S ALG W LI TO POB OR 6536 P 1836

SECTION 18, TOWNSHIP 1 N, RANGE 31 W

TAX ACCOUNT NUMBER 114134000 (14-262)

The assessment of the said property under the said certificate issued was in the name of

CHRISTOPHER S MILSTEAD

Unless said certificate shall be redeemed according to law, the property described therein will be sold to the highest bidder at public auction at 9:00 A.M. on the **first Monday** in the month of April, which is the **7th day of April 2014**.

Dated this 6th day of March 2014.

In accordance with the AMERICANS WITH DISABILITIES ACT, if you are a person with a disability who needs special accommodation in order to participate in this proceeding you are entitled to the provision of certain assistance. Please contact Emily Hogg not later than seven days prior to the proceeding at Escambia County Government Complex, 221 Palafox Place Ste 110, Pensacola FL 32502. Telephone: 850-595-3793.

Personal Services:

CHRISTOPHER S MILSTEAD
1795 MUSCOGEE RD
CANTONMENT, FL 32533-9153

PAM CHILDERS
CLERK OF THE CIRCUIT COURT
ESCAMBIA COUNTY, FLORIDA



By:
Emily Hogg
Deputy Clerk

WARNING

THERE ARE UNPAID TAXES ON PROPERTY WHICH YOU OWN OR IN WHICH YOU HAVE A LEGAL INTEREST. THE PROPERTY WILL BE SOLD AT PUBLIC AUCTION ON April 7, 2014, UNLESS THE TAXES ARE PAID. SHOULD YOU NEED FURTHER INFORMATION CONTACT THE CLERK OF THE CIRCUIT COURT IMMEDIATELY AT THE COUNTY COURTHOUSE IN PENSACOLA, FLORIDA, OR CALL 850-595-3793.

NOTICE OF APPLICATION FOR TAX DEED

NOTICE IS HEREBY GIVEN, That US BANK AS C/F FL DUNDEE LIEN holder of Tax Certificate No. 09080, issued the 1st day of June, A.D., 2011 has filed same in my office and has made application for a tax deed to be issued thereon. Said certificate embraces the following described property in the County of Escambia, State of Florida, to wit:

BEG AT SW COR OF NW 1/4 OF SW 1/4 FOR POB S 89 DEG 39 MIN 34 SEC E ALG S LI 110 FT N 0 DEG 42 MIN 59 SEC W 243 58/100 FT TO SLY R/W LI OF MUSCOGEE RD SW ALG R/W TO W LI OF SEC S ALG W LI TO POB OR 6536 P 1836

SECTION 18, TOWNSHIP 1 N, RANGE 31 W

TAX ACCOUNT NUMBER 114134000 (14-262)

The assessment of the said property under the said certificate issued was in the name of

CHRISTOPHER S MILSTEAD

Unless said certificate shall be redeemed according to law, the property described therein will be sold to the highest bidder at public auction at 9:00 A.M. on the first Monday in the month of April, which is the 7th day of April 2014.

Dated this 6th day of March 2014.

In accordance with the AMERICANS WITH DISABILITIES ACT, if you are a person with a disability who needs special accommodation in order to participate in this proceeding you are entitled to the provision of certain assistance. Please contact Emily Hogg not later than seven days prior to the proceeding at Escambia County Government Complex, 221 Palafox Place Ste 110, Pensacola FL 32502. Telephone: 850-595-3793.

Personal Services:

CHRISTOPHER S MILSTEAD
1795 MUSCOGEE RD
CANTONMENT, FL 32533-9153

PAM CHILDERS
CLERK OF THE CIRCUIT COURT
ESCAMBIA COUNTY, FLORIDA



By:
Emily Hogg
Deputy Clerk

EPAM CHILDERS IA
CLERK OF T
DIVISION OF CIVIL RIGHTS
221 Palfox Place
P.O. Box 333
Pensacola, FL 32591-0333

CERTIFIED MAIL



7006 1830 0000 0236 4475

neopost
03/06/2014
US POSTAGE
FIRST-CLASS MAIL
\$06.48
ZIP 32502
041L1221084



MAR 07 2014
3-12
3-22

CHRISTOPHER S MILSTEAD [14-262]
1795 MUSCOGEE RD
CANTONMENT, FL 32533-9153

CONFIRMED

NIXIE 322 DE 1009 7203/26/14
RETURN TO SENDER
UNDELIVERABLE AS ADDRESSED
UNABLE TO FORWARD

BC: 32591033333 *2087-04887-06-36
32591033333

11/9080