

TAX COLLECTOR'S CERTIFICATION

Application
Date / Number
Oct 13, 2015 / 150384

This is to certify that the holder listed below of Tax Sale Certificate Number **2011 / 4786.0000** , issued the **1st day of June, 2011**, and which encumbers the following described property located in the County of Escambia, State of Florida to wit: **Parcel ID Number: 07-3926-000**

Certificate Holder:
PRO TAX FINANCIAL, LLC US BANK AS CUSTODIAN FOR PR
360 SOUTH TECHNOLOGY COURT
LINDON, UTAH 84042

Property Owner:
KENSELL REBECCA ELLEN
WATTS &
338 EDGEWATER DR
PENSACOLA , FLORIDA 32507

Legal Description:
LOT 13 BLK 2 1ST ADDN TO EDGEWATER PB 3 P 6 OR 3438 P 56 CA 180

has surrendered same in my office and made written application for tax deed in accordance with Florida Statutes. I certify that the following tax certificates, interest, ownership and encumbrance report fee, and Tax Collector's fees have been paid:

CERTIFICATES OWNED BY APPLICANT AND FILED IN CONNECTION WITH THIS TAX DEED APPLICATION:

Cert. Year	Certificate Number	Date of Sale	Face Amt	T/C Fee	Interest	Total
2011	4786.0000	06/01/11	\$900.06	\$0.00	\$238.52	\$1,138.58

CERTIFICATES REDEEMED BY APPLICANT OR INCLUDED (COUNTY) IN CONNECTION WITH THIS APPLICATION:

Cert. Year	Certificate Number	Date of Sale	Face Amt	T/C Fee	Interest	Total
2015	4277.0000	06/01/15	\$855.94	\$6.25	\$64.20	\$926.39
2014	3970.0000	06/01/14	\$839.77	\$6.25	\$163.58	\$1,009.60
2013	4291.0000	06/01/13	\$849.42	\$6.25	\$42.47	\$898.14
2012	4679.0000	06/01/12	\$873.63	\$6.25	\$149.24	\$1,029.12

1. Total of all Certificates in Applicant's Possession and Cost of the Certificates Redeemed by Applicant or Included (County) \$5,001.83
2. Total of Delinquent Taxes Paid by Tax Deed Application \$0.00
3. Total of Current Taxes Paid by Tax Deed Applicant
4. Ownership and Encumbrance Report Fee \$200.00
5. Tax Deed Application Fee \$125.00
6. Total Certified by Tax Collector to Clerk of Court \$5,326.83
7. Clerk of Court Statutory Fee
8. Clerk of Court Certified Mail Charge
9. Clerk of Court Advertising Charge
10. Sheriff's Fee
11.
12. Total of Lines 6 thru 11 \$5,326.83
13. Interest Computed by Clerk of Court Per Florida Statutes.....(%)
14. One-Half of the assessed value of homestead property. If applicable pursuant to section 197.502, F.S.
15. Statutory (Opening) Bid; Total of Lines 12 thru 14
16. Redemption Fee \$6.25
17. Total Amount to Redeem

\$5,001.83
\$0.00
\$200.00
\$125.00
\$5,326.83
\$5,326.83
\$6.25

*Done this 13rd day of October, 2015

TAX COLLECTOR, ESCAMBIA COUNTY, FLORIDA

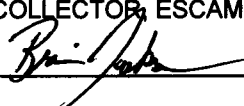
By 

Date of Sale: January 4, 2016

* This certification must be surrendered to the Clerk of the Circuit Court no later than ten days after this date.

Notice to Tax Collector of Application for Tax Deed

TO: Tax Collector of Escambia County

In accordance with Florida Statutes, I,

**PRO TAX FINANCIAL, LLC US BANK AS CUSTODIAN
FOR PR
360 SOUTH TECHNOLOGY COURT
LINDON, Utah, 84042**

holder of the following tax sale certificate hereby surrender same to the Tax Collector and make tax deed application thereon:

Certificate No.	Parcel ID Number	Date	Legal Description
4786.0000	07-3926-000	06/01/2011	LOT 13 BLK 2 1ST ADDN TO EDGEWATER PB 3 P 6 OR 3438 P 56 CA 180

2014 TAX ROLL

KENSELL REBECCA ELLEN
WATTS &
338 EDGEWATER DR
PENSACOLA , Florida 32507

I agree to pay all delinquent taxes, redeem all outstanding certificates not in my possession, pay any omitted taxes, and pay current taxes, if due, covering the land, and pay any interest earned (a) on tax certificates not in my possession, (b) on omitted taxes or (c) on delinquent taxes. I also agree to pay all Tax Collector's fees, ownership and encumbrance reports costs, Clerk of the Court costs, charges and fees and Sheriff's costs, if applicable. Attached is the above-mentioned tax sale certificate on which this application is based and all other certificates of the same legal description which are in my possession.

Swalker (Blair Poelman)

Applicant's Signature

10/13/2015

Date



Chris Jones Escambia County Property Appraiser

- Real Estate Search
- Tangible Property Search
- Sale List
- Amendment 1/Portability Calculations

[Back](#)

Navigate Mode
 Account
 Reference

[Printer Friendly Version](#)

General Information	
Reference:	372S301001013002
Account:	073926000
Owners:	KENSELL REBECCA ELLEN WATTS & DELLINGER BOBBIE MARIE
Mail:	338 EDGEWATER DR PENSACOLA, FL 32507
Situs:	607 CHASEVILLE ST 32507
Use Code:	SINGLE FAMILY RESID
Taxing Authority:	COUNTY MSTU
Tax Inquiry:	Open Tax Inquiry Window
Tax Inquiry link courtesy of Janet Holley Escambia County Tax Collector	

Assessments				
Year	Land	Imprv	Total	Cap Val
2015	\$8,000	\$34,118	\$42,118	\$42,118
2014	\$13,300	\$32,184	\$45,484	\$45,484
2013	\$13,300	\$30,514	\$43,814	\$43,814

[Disclaimer](#)

[Amendment 1/Portability Calculations](#)

Sales Data					
Sale Date	Book	Page	Value	Type	Official Records (New Window)
09/1993	3438	56	\$25,000	WD	View Instr

Official Records Inquiry courtesy of Pam Childers
Escambia County Clerk of the Circuit Court and Comptroller

2015 Certified Roll Exemptions
None

Legal Description
LOT 13 BLK 2 1ST ADDN TO EDGEWATER PB 3 P 6 OR 3438 P 56 CA 180

Extra Features
None

Parcel Information [Launch Interactive Map](#)

Section Map Id:
CA180

Approx. Acreage:
0.2500

Zoned:
MDR

Evacuation & Flood Information
[Open Report](#)

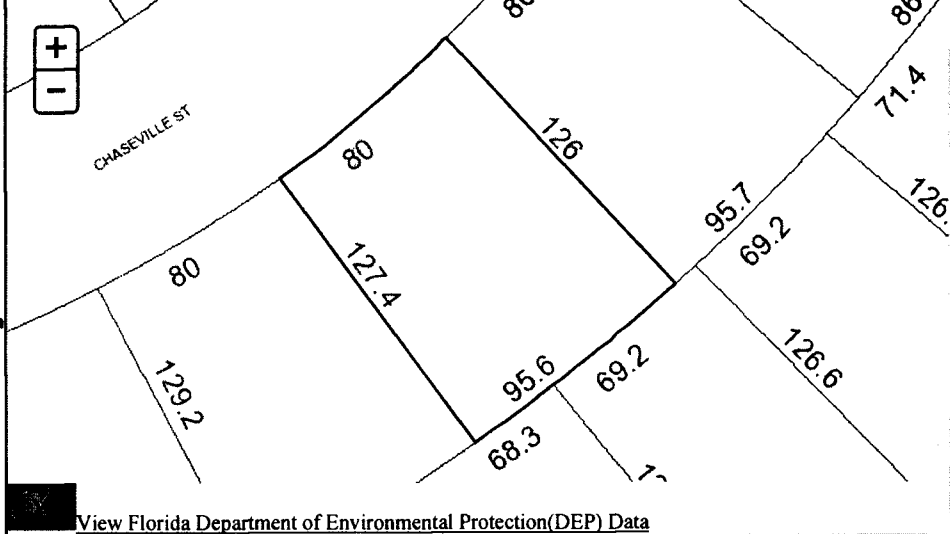

Buildings

Address: 607 CHASEVILLE ST, Year Built: 1952, Effective Year: 1952

Structural Elements
DECOR/MILLWORK-AVERAGE
DWELLING UNITS-1
EXTERIOR WALL-CONCRETE BLOCK
FLOOR COVER-ASPHALT TILE
FOUNDATION-SLAB ON GRADE
HEAT/AIR-WALL/FLOOR FURN
INTERIOR WALL-DRYWALL-PLASTER

NO. PLUMBING FIXTURES-3
NO. STORIES-1
ROOF COVER-COMPOSITION SHG
ROOF FRAMING-HIP
STORY HEIGHT-0
STRUCTURAL FRAME-WOOD FRAME

Areas - 1751 Total SF

BASE AREA - 1256
CARPORT FIN - 220
OPEN PORCH FIN - 10
OPEN PORCH UNF - 210
UTILITY UNF - 55

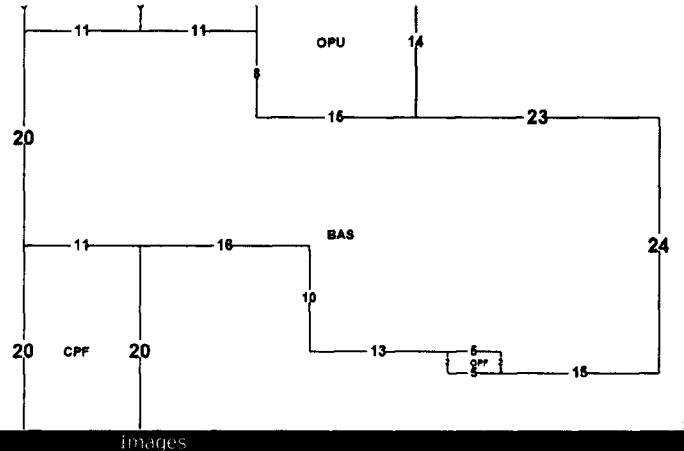

Images



2/28/03

The primary use of the assessment data is for the preparation of the current year tax roll. No responsibility or liability is assumed for inaccuracies or errors.

Southern Guaranty Title Company

4400 Bayou Boulevard, Suite 13B

Pensacola, Florida 32503

Telephone: 850-478-8121

Facsimile: 850-476-1437

OWNERSHIP AND ENCUMBRANCE REPORT

File No.: 12420

November 16, 2015

Escambia County Tax Collector
P.O. Box 1312
Pensacola, Florida 32591

Pursuant to your request, the Company has caused a search to be made of the Public Records of Escambia County, Florida, solely as revealed by records maintained from 01-16-1995, through 01-16-2015, and said search reveals the following:

1. THE GRANTEE(S) OF THE LAST DEED(S) OF RECORD IS:

Rebecca E.Kensell FKA Rebecca Ellen Watts, and Bobbi Marie Dellinger

2. The land covered by this Report is:

LEGAL DESCRIPTION IS ATTACHED HERETO AND MADE A PART HEREOF

3. The following unsatisfied mortgages, liens and judgments affecting the land covered by this Report appear of record:

SEE CONTINUATION PAGE ATTACHED HERETO AND MADE A PART HEREOF

4. Taxes:

SEE CONTINUATION PAGE ATTACHED HERETO AND MADE A PART HEREOF

The foregoing report is prepared and furnished for information only, is not intended to constitute or imply any opinion, warranty, guaranty, insurance, or similar assurance as to the status of title, and no determination has been made of the authenticity of any instrument described or referred to herein. The name search for the purposes of determining applicable judgments and liens is limited to the apparent record owner(s) shown herein, No attempt has been made to determine whether the land is subject to liens or assessments which are not shown as existing liens by the public records. The Company's liability hereunder shall not exceed the cost of this Report, or \$1,000.00 whichever is less.

THIS REPORT SHALL NOT BE USED FOR THE ISSUANCE OF TITLE INSURANCE.

Southern Guaranty Title Company

By: 

November 16, 2015

**OWNERSHIP AND ENCUMBRANCE REPORT
LEGAL DESCRIPTION**

File No.: 12420

November 16, 2015

Lot 13, Block 2, First Addition to Edgewater Subdivision, as per plat thereof, recorded in Plat Book 3, Page 6, of the Public Records of Escambia County, Florida

**OWNERSHIP AND ENCUMBRANCE REPORT
CONTINUATION PAGE**

File No.: 12420

November 16, 2015

UNSATISFIED MORTGAGES, LIENS AND JUDGMENTS AFFECTING THE LAND COVERED BY THIS REPORT THAT APPEAR OF RECORD:

1. MSBU Lien filed by Escambia County recorded in O.R. Book 4316, page 1993, and O.R. Book 4452, page 503.
2. Taxes for the year 2010-2014 delinquent. The assessed value is \$42,118.00. Tax ID 07-3926-000.

PLEASE NOTE THE FOLLOWING:

- A. Subject to current year taxes.
- B. Taxes and assessments due now or in subsequent years.
- C. Subject to Easements, Restrictions and Covenants of record.
- D. Encroachments, overlaps, boundary line disputes, and any other matters which would be disclosed by an accurate survey and inspection of the premises.
- E. Oil, gas and mineral or any other subsurface rights of any kind or nature.

SOUTHERN GUARANTY TITLE COMPANY

4400 BAYOU BLVD., SUITE 13-B, CORDOVA SQUARE

PENSACOLA, FLORIDA 32503

TEL. (850) 478-8121 FAX (850) 476-1437

Email: rcsgr@aol.com

Janet Holley
Escambia County Tax Collector
P.O. Box 1312
Pensacola, FL 32596

CERTIFICATION: TITLE SEARCH FOR TDA

TAX DEED SALE DATE: 1-4-2016

TAX ACCOUNT NO.: 07-3926-000

CERTIFICATE NO.: 2011-4786

In compliance with Section 197.256, Florida Statutes, the following is a list of names and addresses of those persons, firms and/or agencies having legal interest in or claim against the above described property. The above referenced tax sale certificate is being submitted as proper notification of tax deed sale.

YES NO

- Notify City of Pensacola, P.O. Box 12910, 32521
221 Palafox Place, 4th Floor/
 Notify Escambia County, 190 Governmental Center, 32502
 Homestead for tax year.

Rebecca E. Kensell fka
Rebecca Ellen Watts
Bobbie Marie Dellinger
338 Edgewater Dr.
Pensacoal, FL 32507
and
607 Chaseville St.
Pensacola, FL 32507

Certified and delivered to Escambia County Tax Collector,
this 17th day of November, 2015.

SOUTHERN GUARANTY TITLE COMPANY

by: Richard S. Combs, President

NOTE: The above listed addresses are based upon current information available, but said addresses are not guaranteed to be true or correct.

Prepared by: JAMES C. TAYLOR
Taylor & Van Matre, P.A.
4300 Bayou Blvd. Suite 16 Pensacola, FL 32503
Incidental to the issuance of a title insurance policy.
File No.: REC-630
Parcel ID #
Grantee(s) SS #

343876 056

WARRANTY DEED
(INDIVIDUAL)

This WARRANTY DEED, dated September 21, 1993 by LINDA SUE ROBBINS

whose post office address is 6213 Sarah Drive, Pensacola, Florida 32503

hereinafter called the GRANTOR, to REBECCA ELLEN WATTS, A SINGLE WOMAN and BOBBIE MARIE DELLINGER, A MARRIED WOMAN, AS JOINT TENANTS WITH RIGHT OF SURVIVORSHIP AND NOT AS
whose post office address is TENANTS IN COMMON 607 Chaseville St., Pensacola, Fl. 32507

hereinafter called the GRANTEE:
(Whenever used herein the terms "GRANTOR" and "GRANTEE" include all the parties to this instrument and the heirs, legal representatives and assigns of individuals, and the successors and assigns of corporations.)
WITNESSETH: That the GRANTOR, for and in consideration of the sum of \$10.00 and other valuable considerations, receipt whereof is hereby acknowledged, hereby grants, bargains, sells, aliens, reissues, releases, conveys and confirms unto the GRANTEE, all that certain land situate in ESCAMBIA County, Florida, viz:

LOT THIRTEEN (13), BLOCK TWO (2), FIRST ADDITION TO EDGEWATER SUBDIVISION, A SUBDIVISION OF A PORTION OF SECTIONS 37 AND 52, TOWNSHIP 2 SOUTH, RANGE 30 WEST, ESCAMBIA COUNTY, FLORIDA, ACCORDING TO PLAT OF SAID SUBDIVISION RECORDED IN PLAT BOOK 3, AT PAGE 6, OF THE PUBLIC RECORDS OF SAID COUNTY.

Grantor hereby warrants that the property described in this instrument is not his constitutional homestead as provided by the Florida Constitution.

D.S. PD \$ 125.00
DATE 9-23-93
JOE A. FLEMING, Notary Public
BY: J. C. Taylor, D.C.
CENT. REG. NO. 2013328-27-01

SUBJECT TO covenants, conditions, restrictions, reservations, limitations, easements and agreements of record, if any; taxes and assessments for the year 1993 and subsequent years; and to all applicable zoning ordinances and/or restrictions and prohibitions imposed by governmental authorities, if any,

TOGETHER with all the tenements, hereditaments and appurtenances thereto belonging or in anywise appertaining.

TO HAVE AND TO HOLD, the same in fee simple forever.

AND THE GRANTOR hereby covenants with said GRANTEE that except as above noted, the GRANTOR is lawfully seized of said land in fee simple; that the GRANTOR has good right and lawful authority to sell and convey said land; that the GRANTOR hereby fully warrants the title to said land and will defend the same against the lawful claims of all persons whatsoever.

IN WITNESS WHEREOF, GRANTOR has signed and sealed these presents the date set forth above.

SIGNED IN THE PRESENCE OF THE FOLLOWING WITNESSES: Linda Sue Robbins
LINDA SUE ROBBINS

Signature: Linda S. Robbins
Print Name: LINDA SUE ROBBINS
Signature: J. C. Taylor
Print Name: J. C. TAYLOR

State of Florida
County of ESCAMBIA

I am a notary public of the state of Florida and my commission expires:

THE FOREGOING INSTRUMENT was acknowledged before me on September 21, 1993 by LINDA SUE ROBBINS

who is personally known to me or who has produced as identification and who DID NOT take an oath.
(type of identification) (did/did not)



Signature: [Signature]
Print Name: Notary Public

**STATE OF FLORIDA
COUNTY OF ESCAMBIA**

**CERTIFICATE OF NOTICE OF MAILING
NOTICE OF APPLICATION FOR TAX DEED**

CERTIFICATE # 04786 of 2011

I, PAM CHILDERS, CLERK OF THE CIRCUIT COURT OF ESCAMBIA COUNTY, FLORIDA, do hereby certify that I did on December 3, 2015, mail a copy of the foregoing Notice of Application for Tax Deed, addressed to:

REBECCA ELLEN WATTS KENSELL 338 EDGEWATER DR PENSACOLA, FL 32507	BOBBIE MARIE DELLINGER 338 EDGEWATER DR PENSACOLA, FL 32507
REBECCA E KENSELL FKA REBECCA ELLEN WATTS 607 CHASEVILLE ST PENSACOLA FL 32507	BOBBIE MARIE DELLINGER 607 CHASEVILLE ST PENSACOLA FL 32507
ESCAMBIA COUNTY OFFICE OF COUNTY ATTORNEY 221 PALAFOX PLACE STE 430 PENSACOLA FL 32502	

WITNESS my official seal this 3rd day of December 2015.

PAM CHILDERS
CLERK OF THE CIRCUIT COURT
ESCAMBIA COUNTY, FLORIDA



By:
Emily Hogg
Deputy Clerk

WARNING

THERE ARE UNPAID TAXES ON PROPERTY WHICH YOU OWN OR IN WHICH YOU HAVE A LEGAL INTEREST. THE PROPERTY WILL BE SOLD AT PUBLIC AUCTION ON January 4, 2016, UNLESS THE TAXES ARE PAID. SHOULD YOU NEED FURTHER INFORMATION CONTACT THE CLERK OF THE CIRCUIT COURT IMMEDIATELY AT THE COUNTY COURTHOUSE IN PENSACOLA, FLORIDA, OR CALL 850-595-3793.

NOTICE OF APPLICATION FOR TAX DEED

NOTICE IS HEREBY GIVEN, That **PRO TAX FINANCIAL LLC US BANK AS CUSTODIAN FOR PR** holder of **Tax Certificate No. 04786**, issued the **1st day of June, A.D., 2011** has filed same in my office and has made application for a tax deed to be issued thereon. Said certificate embraces the following described property in the County of Escambia, State of Florida, to wit:

LOT 13 BLK 2 1ST ADDN TO EDGEWATER PB 3 P 6 OR 3438 P 56 CA 180

SECTION 37, TOWNSHIP 2 S, RANGE 30 W

TAX ACCOUNT NUMBER 073926000 (16-006)

The assessment of the said property under the said certificate issued was in the name of

REBECCA ELLEN WATTS KENSELL and BOBBIE MARIE DELLINGER

Unless said certificate shall be redeemed according to law, the property described therein will be sold to the highest bidder at public auction at 9:00 A.M. on the **first Monday** in the month of January, which is the **4th day of January 2016**.

Dated this 3rd day of December 2015.

In accordance with the AMERICANS WITH DISABILITIES ACT, if you are a person with a disability who needs special accommodation in order to participate in this proceeding you are entitled to the provision of certain assistance. Please contact Emily Hogg not later than seven days prior to the proceeding at Escambia County Government Complex, 221 Palafox Place Ste 110, Pensacola FL 32502. Telephone: 850-595-3793.



PAM CHILDERS
CLERK OF THE CIRCUIT COURT
ESCAMBIA COUNTY, FLORIDA

By:
Emily Hogg
Deputy Clerk

WARNING

THERE ARE UNPAID TAXES ON PROPERTY WHICH YOU OWN OR IN WHICH YOU HAVE A LEGAL INTEREST. THE PROPERTY WILL BE SOLD AT PUBLIC AUCTION ON January 4, 2016, UNLESS THE TAXES ARE PAID. SHOULD YOU NEED FURTHER INFORMATION CONTACT THE CLERK OF THE CIRCUIT COURT IMMEDIATELY AT THE COUNTY COURTHOUSE IN PENSACOLA, FLORIDA, OR CALL 850-595-3793.

NOTICE OF APPLICATION FOR TAX DEED

NOTICE IS HEREBY GIVEN, That **PRO TAX FINANCIAL LLC US BANK AS CUSTODIAN FOR PR** holder of Tax Certificate No. **04786**, issued the 1st day of June, A.D., 2011 has filed same in my office and has made application for a tax deed to be issued thereon. Said certificate embraces the following described property in the County of Escambia, State of Florida, to wit:

LOT 13 BLK 2 1ST ADDN TO EDGEWATER PB 3 P 6 OR 3438 P 56 CA 180

SECTION 37, TOWNSHIP 2 S, RANGE 30 W

TAX ACCOUNT NUMBER 073926000 (16-006)

The assessment of the said property under the said certificate issued was in the name of

REBECCA ELLEN WATTS KENSELL and BOBBIE MARIE DELLINGER

Unless said certificate shall be redeemed according to law, the property described therein will be sold to the highest bidder at public auction at 9:00 A.M. on the first Monday in the month of January, which is the 4th day of January 2016.

Dated this 3rd day of December 2015.

In accordance with the AMERICANS WITH DISABILITIES ACT, if you are a person with a disability who needs special accommodation in order to participate in this proceeding you are entitled to the provision of certain assistance. Please contact Emily Hogg not later than seven days prior to the proceeding at Escambia County Government Complex, 221 Palafox Place Ste 110, Pensacola FL 32502. Telephone: 850-595-3793.

Post Property:

607 CHASEVILLE ST 32507



PAM CHILDERS
CLERK OF THE CIRCUIT COURT
ESCAMBIA COUNTY, FLORIDA

By:
Emily Hogg
Deputy Clerk

WARNING

THERE ARE UNPAID TAXES ON PROPERTY WHICH YOU OWN OR IN WHICH YOU HAVE A LEGAL INTEREST. THE PROPERTY WILL BE SOLD AT PUBLIC AUCTION ON January 4, 2016, UNLESS THE TAXES ARE PAID. SHOULD YOU NEED FURTHER INFORMATION CONTACT THE CLERK OF THE CIRCUIT COURT IMMEDIATELY AT THE COUNTY COURTHOUSE IN PENSACOLA, FLORIDA, OR CALL 850-595-3793.

NOTICE OF APPLICATION FOR TAX DEED

NOTICE IS HEREBY GIVEN, That **PRO TAX FINANCIAL LLC US BANK AS CUSTODIAN FOR PR** holder of Tax Certificate No. 04786, issued the 1st day of June, A.D., 2011 has filed same in my office and has made application for a tax deed to be issued thereon. Said certificate embraces the following described property in the County of Escambia, State of Florida, to wit:

LOT 13 BLK 2 1ST ADDN TO EDGEWATER PB 3 P 6 OR 3438 P 56 CA 180

SECTION 37, TOWNSHIP 2 S, RANGE 30 W

TAX ACCOUNT NUMBER 073926000 (16-006)

The assessment of the said property under the said certificate issued was in the name of

REBECCA ELLEN WATTS KENSELL and BOBBIE MARIE DELLINGER

Unless said certificate shall be redeemed according to law, the property described therein will be sold to the highest bidder at public auction at 9:00 A.M. on the first Monday in the month of January, which is the 4th day of January 2016.

Dated this 3rd day of December 2015.

In accordance with the AMERICANS WITH DISABILITIES ACT, if you are a person with a disability who needs special accommodation in order to participate in this proceeding you are entitled to the provision of certain assistance. Please contact Emily Hogg not later than seven days prior to the proceeding at Escambia County Government Complex, 221 Palafox Place Ste 110, Pensacola FL 32502. Telephone: 850-595-3793.

Personal Services:

REBECCA ELLEN WATTS KENSELL
338 EDGEWATER DR
PENSACOLA, FL 32507

PAM CHILDERS
CLERK OF THE CIRCUIT COURT
ESCAMBIA COUNTY, FLORIDA



By:
Emily Hogg
Deputy Clerk

WARNING

THERE ARE UNPAID TAXES ON PROPERTY WHICH YOU OWN OR IN WHICH YOU HAVE A LEGAL INTEREST. THE PROPERTY WILL BE SOLD AT PUBLIC AUCTION ON **January 4, 2016**, UNLESS THE TAXES ARE PAID. SHOULD YOU NEED FURTHER INFORMATION CONTACT THE CLERK OF THE CIRCUIT COURT IMMEDIATELY AT THE COUNTY COURTHOUSE IN PENSACOLA, FLORIDA, OR CALL 850-595-3793.

NOTICE OF APPLICATION FOR TAX DEED

NOTICE IS HEREBY GIVEN, That **PRO TAX FINANCIAL LLC US BANK AS CUSTODIAN FOR PR** holder of **Tax Certificate No. 04786**, issued the **1st day of June, A.D., 2011** has filed same in my office and has made application for a tax deed to be issued thereon. Said certificate embraces the following described property in the County of Escambia, State of Florida, to wit:

LOT 13 BLK 2 1ST ADDN TO EDGEWATER PB 3 P 6 OR 3438 P 56 CA 180

SECTION 37, TOWNSHIP 2 S, RANGE 30 W

TAX ACCOUNT NUMBER 073926000 (16-006)

The assessment of the said property under the said certificate issued was in the name of

REBECCA ELLEN WATTS KENSELL and BOBBIE MARIE DELLINGER

Unless said certificate shall be redeemed according to law, the property described therein will be sold to the highest bidder at public auction at 9:00 A.M. on the **first Monday** in the month of **January**, which is the **4th day of January 2016**.

Dated this 3rd day of December 2015.

In accordance with the AMERICANS WITH DISABILITIES ACT, if you are a person with a disability who needs special accommodation in order to participate in this proceeding you are entitled to the provision of certain assistance. Please contact Emily Hogg not later than seven days prior to the proceeding at Escambia County Government Complex, 221 Palafox Place Ste 110, Pensacola FL 32502. Telephone: 850-595-3793.

Personal Services:

BOBBIE MARIE DELLINGER
338 EDGEWATER DR
PENSACOLA, FL 32507

PAM CHILDERS
CLERK OF THE CIRCUIT COURT
ESCAMBIA COUNTY, FLORIDA



By:
Emily Hogg
Deputy Clerk

11/4786

7007 1490 0002 6737 7011

U.S. Postal Service
CERTIFIED MAIL RECEIPT
(Domestic Mail Only; No Insurance Coverage Provided)

For delivery information visit our website at www.usps.com
OFFICIAL USE

Postage	\$.48
Certified Fee	3.45
Return Receipt Fee (Endorsement Required)	2.80
Restricted Delivery Fee (Endorsement Required)	
Total Postage & Fees	\$ 6.73

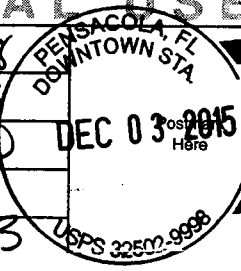

Sent To ESCAMBIA COUNTY [16-006]
OFFICE OF COUNTY ATTORNEY
221 PALAFOX PLACE STE 430
PENSACOLA FL 32502

7007 1490 0002 6737 7004

U.S. Postal Service
CERTIFIED MAIL RECEIPT
(Domestic Mail Only; No Insurance Coverage Provided)

For delivery information visit our website at www.usps.com
OFFICIAL USE

Postage	\$.48
Certified Fee	3.45
Return Receipt Fee (Endorsement Required)	2.80
Restricted Delivery Fee (Endorsement Required)	
Total Postage & Fees	\$ 6.73

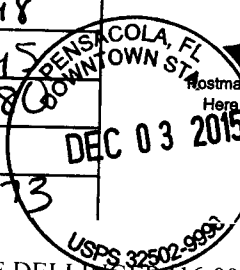

Sent To BOBBIE MARIE DELLINGER [16-006]
607 CHASEVILLE ST
PENSACOLA FL 32507

7007 1490 0002 6737 6991

U.S. Postal Service
CERTIFIED MAIL RECEIPT
(Domestic Mail Only; No Insurance Coverage Provided)

For delivery information visit our website at www.usps.com
OFFICIAL USE

Postage	\$.48
Certified Fee	3.45
Return Receipt Fee (Endorsement Required)	2.80
Restricted Delivery Fee (Endorsement Required)	
Total Postage & Fees	\$ 6.73

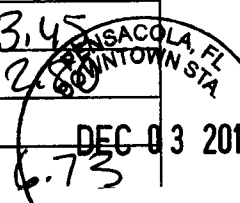

Sent To REBECCA E KENSSELL FKA REE
ELLEN WATTS [16-006]
607 CHASEVILLE ST
PENSACOLA FL 32507

7007 1490 0002 6737 6977

U.S. Postal Service
CERTIFIED MAIL RECEIPT
(Domestic Mail Only; No Insurance Coverage Provided)

For delivery information visit our website at www.usps.com
OFFICIAL USE

Postage	\$.48
Certified Fee	3.45
Return Receipt Fee (Endorsement Required)	2.80
Restricted Delivery Fee (Endorsement Required)	
Total Postage & Fees	\$ 6.73

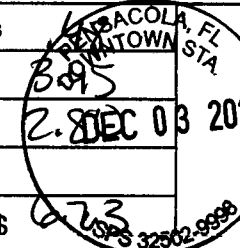

Sent To REBECCA ELLEN WATTS KENSSELL
[16-006]
338 EDGEWATER DR
PENSACOLA, FL 32507

7007 1490 0002 6737 6984

U.S. Postal Service
CERTIFIED MAIL RECEIPT
(Domestic Mail Only; No Insurance Coverage Provided)

For delivery information visit our website at www.usps.com
OFFICIAL USE

Postage	\$.48
Certified Fee	3.45
Return Receipt Fee (Endorsement Required)	2.80
Restricted Delivery Fee (Endorsement Required)	
Total Postage & Fees	\$ 6.73

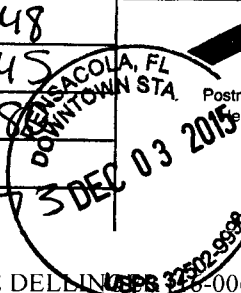

Sent To BOBBIE MARIE DELLINGER [16-006]
338 EDGEWATER DR
PENSACOLA, FL 32507

11/4786

SENDER: COMPLETE THIS SECTION	COMPLETE THIS SECTION ON DELIVERY	
<ul style="list-style-type: none"> Complete items 1, 2, and 3. Also complete item 4 if Restricted Delivery is desired. Print your name and address on the reverse so that we can return the card to you. Attach this card to the back of the mailpiece, or on the front if space permits. 	A. Signature  <input type="checkbox"/> Agent <input type="checkbox"/> Addressee	
	B. Received by (Printed Name)	C. Date of Delivery
1. Article Addressed to:	D. Is delivery address different from item 1? <input type="checkbox"/> Yes If YES, enter delivery address below: <input type="checkbox"/> No	
BOBBIE MARIE DELLINGER [16-006] 607 CHASEVILLE ST PENSACOLA FL 32507	3. Service Type <input checked="" type="checkbox"/> Certified Mail® <input type="checkbox"/> Priority Mail Express™ <input type="checkbox"/> Registered <input type="checkbox"/> Return Receipt for Merchandise <input type="checkbox"/> Insured Mail <input type="checkbox"/> Collect on Delivery	
2. Article Number (Transfer from service label)	4. Restricted Delivery? (Extra Fee) <input type="checkbox"/> Yes	
	7007 1490 0002 6737 7004	
PS Form 3811, July 2013 Domestic Return Receipt		

SENDER: COMPLETE THIS SECTION	COMPLETE THIS SECTION ON DELIVERY	
<ul style="list-style-type: none"> Complete items 1, 2, and 3. Also complete item 4 if Restricted Delivery is desired. Print your name and address on the reverse so that we can return the card to you. Attach this card to the back of the mailpiece, or on the front if space permits. 	A. Signature  <input type="checkbox"/> Agent <input type="checkbox"/> Addressee	
	B. Received by (Printed Name)	C. Date of Delivery
1. Article Addressed to:	D. Is delivery address different from item 1? <input type="checkbox"/> Yes If YES, enter delivery address below: <input type="checkbox"/> No	
REBECCA ELLEN WATTS KENSELL [16-006] 338 EDGEWATER DR PENSACOLA, FL 32507	3. Service Type <input checked="" type="checkbox"/> Certified Mail® <input type="checkbox"/> Priority Mail Express™ <input type="checkbox"/> Registered <input type="checkbox"/> Return Receipt for Merchandise <input type="checkbox"/> Insured Mail <input type="checkbox"/> Collect on Delivery	
2. Article Number (Transfer from service label)	4. Restricted Delivery? (Extra Fee) <input type="checkbox"/> Yes	
	7007 1490 0002 6737 6977	
PS Form 3811, July 2013 Domestic Return Receipt		

11/4786

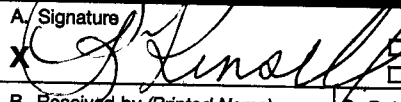
SENDER: COMPLETE THIS SECTION		COMPLETE THIS SECTION ON DELIVERY	
<ul style="list-style-type: none"> Complete items 1, 2, and 3. Also complete item 4 if Restricted Delivery is desired. Print your name and address on the reverse so that we can return the card to you. Attach this card to the back of the mailpiece, or on the front if space permits. 		A. Signature  <input type="checkbox"/> Agent <input checked="" type="checkbox"/> Addressee	
1. Article Addressed to:		B. Received by (Printed Name)	C. Date of Delivery
REBECCA E KENSELL FKA REBECCA ELLEN WATTS [16-006] 607 CHASEVILLE ST PENSACOLA FL 32507		D. Is delivery address different from item 1? <input type="checkbox"/> Yes If YES, enter delivery address below: <input type="checkbox"/> No	
2. Article Number		3. Service Type	
(Transfer from service label)		<input checked="" type="checkbox"/> Certified Mail® <input type="checkbox"/> Priority Mail Express™ <input type="checkbox"/> Registered <input type="checkbox"/> Return Receipt for Merchandise <input type="checkbox"/> Insured Mail <input type="checkbox"/> Collect on Delivery	
7007 1490 0002 6737 6991		4. Restricted Delivery? (Extra Fee) <input type="checkbox"/> Yes	

PS Form 3811, July 2013 Domestic Return Receipt

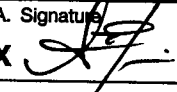
SENDER: COMPLETE THIS SECTION		COMPLETE THIS SECTION ON DELIVERY	
<ul style="list-style-type: none"> Complete items 1, 2, and 3. Also complete item 4 if Restricted Delivery is desired. Print your name and address on the reverse so that we can return the card to you. Attach this card to the back of the mailpiece, or on the front if space permits. 		A. Signature  <input type="checkbox"/> Agent <input checked="" type="checkbox"/> Addressee	
1. Article Addressed to:		B. Received by (Printed Name)	C. Date of Delivery
ESCAMBIA COUNTY [16-006] OFFICE OF COUNTY ATTORNEY 221 PALAFOX PLACE STE 430 PENSACOLA FL 32502		D. Is delivery address different from item 1? <input type="checkbox"/> Yes If YES, enter delivery address below: <input checked="" type="checkbox"/> No	
2. Article Number		3. Service Type	
(Transfer from service label)		<input checked="" type="checkbox"/> Certified Mail® <input type="checkbox"/> Priority Mail Express™ <input type="checkbox"/> Registered <input type="checkbox"/> Return Receipt for Merchandise <input type="checkbox"/> Insured Mail <input type="checkbox"/> Collect on Delivery	
7007 1490 0002 6737 7011		4. Restricted Delivery? (Extra Fee) <input type="checkbox"/> Yes	

PS Form 3811, July 2013 Domestic Return Receipt

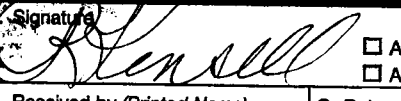
SENDER: COMPLETE THIS SECTION		COMPLETE THIS SECTION ON DELIVERY	
<ul style="list-style-type: none"> Complete items 1, 2, and 3. Also complete item 4 if Restricted Delivery is desired. Print your name and address on the reverse so that we can return the card to you. Attach this card to the back of the mailpiece, or on the front if space permits. 		A. Signature  <input type="checkbox"/> Agent <input checked="" type="checkbox"/> Addressee	
1. Article Addressed to:		B. Received by (Printed Name)	C. Date of Delivery
BOBBIE MARIE DELLINGER [16-006] 338 EDGEWATER DR PENSACOLA, FL 32507		D. Is delivery address different from item 1? <input type="checkbox"/> Yes If YES, enter delivery address below: <input type="checkbox"/> No	
2. Article Number		3. Service Type	
(Transfer from service label)		<input checked="" type="checkbox"/> Certified Mail® <input type="checkbox"/> Priority Mail Express™ <input type="checkbox"/> Registered <input type="checkbox"/> Return Receipt for Merchandise <input type="checkbox"/> Insured Mail <input type="checkbox"/> Collect on Delivery	
7007 1490 0002 6737 6984		4. Restricted Delivery? (Extra Fee) <input type="checkbox"/> Yes	

PS Form 3811, July 2013 Domestic Return Receipt

ESCAMBIA COUNTY SHERIFF'S OFFICE
ESCAMBIA COUNTY, FLORIDA

16-006

NON-ENFORCEABLE RETURN OF SERVICE

Document Number: ECSO15CIV055157NON

Agency Number: 16-002453

Court: TAX DEED

County: ESCAMBIA

Case Number: CERT NO 04786 2011

Attorney/Agent:

PAM CHILDERS
CLERK OF COURT
TAX DEED

Plaintiff: RE: REBECCA ELLEN WATTS KENSELL AND BOBBIE MARIE DELLINGER

Defendant:

Type of Process: NOTICE OF APPLICATION FOR TAX DEED

Received this Writ on 12/3/2015 at 2:04 PM and served same at 10:46 AM on 12/7/2015 in ESCAMBIA COUNTY, FLORIDA, by serving POST PROPERTY , the within named, to wit: , .

POSTED TO PROPERTY AS INSTRUCTED BY CLERK'S OFFICE.

DAVID MORGAN, SHERIFF
ESCAMBIA COUNTY, FLORIDA

By: _____

R. WISE, CPS

Service Fee: \$40.00

Receipt No: BILL

Printed By: DLRUPERT

WARNING

THERE ARE UNPAID TAXES ON PROPERTY WHICH YOU OWN OR IN WHICH YOU HAVE A LEGAL INTEREST. THE PROPERTY WILL BE SOLD AT PUBLIC AUCTION ON January 4, 2016, UNLESS THE TAXES ARE PAID. SHOULD YOU NEED FURTHER INFORMATION CONTACT THE CLERK OF THE CIRCUIT COURT IMMEDIATELY AT THE COUNTY COURTHOUSE IN PENSACOLA, FLORIDA, OR CALL 850-595-3793.

NOTICE OF APPLICATION FOR TAX DEED

NOTICE IS HEREBY GIVEN, That **PRO TAX FINANCIAL LLC US BANK AS CUSTODIAN FOR PR** holder of **Tax Certificate No. 04786**, issued the **1st day of June, A.D., 2011** has filed same in my office and has made application for a tax deed to be issued thereon. Said certificate embraces the following described property in the County of Escambia, State of Florida, to wit:

LOT 13 BLK 2 1ST ADDN TO EDGEWATER PB 3 P 6 OR 3438 P 56 CA 180

SECTION 37, TOWNSHIP 2 S, RANGE 30 W

TAX ACCOUNT NUMBER 073926000 (16-006)

The assessment of the said property under the said certificate issued was in the name of

REBECCA ELLEN WATTS KENSELL and BOBBIE MARIE DELLINGER

Unless said certificate shall be redeemed according to law, the property described therein will be sold to the highest bidder at public auction at 9:00 A.M. on the **first Monday** in the month of January, which is the **4th day of January 2016**.

Dated this 3rd day of December 2015.

In accordance with the AMERICANS WITH DISABILITIES ACT, if you are a person with a disability who needs special accommodation in order to participate in this proceeding you are entitled to the provision of certain assistance. Please contact Emily Hogg not later than seven days prior to the proceeding at Escambia County Government Complex, 221 Palafox Place Ste 110, Pensacola FL 32502. Telephone: 850-595-3793.

Post Property:
607 CHASEVILLE ST 32507

PAM CHILDERS
CLERK OF THE CIRCUIT COURT
ESCAMBIA COUNTY, FLORIDA



By:
Emily Hogg
Deputy Clerk

ESCAMBIA COUNTY SHERIFF'S OFFICE
ESCAMBIA COUNTY, FLORIDA

16-006

NON-ENFORCEABLE RETURN OF SERVICE

Document Number: ECSO15CIV055201NON

Agency Number: 16-002435

Court: TAX DEED

County: ESCAMBIA

Case Number: CERT # 04786 2011

Attorney/Agent:

PAM CHILDERS
CLERK OF COURT
TAX DEED

Plaintiff: IN RE REBECCA ELLEN WATTS KENSELL AND BOBBIE MARIE DELLINGER

Defendant:

Type of Process: NOTICE OF APPLICATION FOR TAX DEED

Substitute

Received this Writ on 12/3/2015 at 2:03 PM and served same on BOBBIE MARIE DELLINGER , in ESCAMBIA COUNTY, FLORIDA, at 11:00 AM on 12/7/2015 by leaving a true copy of this Writ together with a copy of the initial pleadings, if any, with the date and hour of service endorsed thereon by me, at the within named individual's usual place of abode, with a person residing therein who is 15 years of age, or older, to wit: RICH KENSELL, RESIDENT, as a member of the household and informing said person of their contents.

DAVID MORGAN, SHERIFF
ESCAMBIA COUNTY, FLORIDA

By: _____

P. Wise 925
P. WISE, CPS

Service Fee: \$40.00

Receipt No: BILL

Printed By: DLRUPERT

WARNING

THERE ARE UNPAID TAXES ON PROPERTY WHICH YOU OWN OR IN WHICH YOU HAVE A LEGAL INTEREST. THE PROPERTY WILL BE SOLD AT PUBLIC AUCTION ON January 4, 2016, UNLESS THE TAXES ARE PAID. SHOULD YOU NEED FURTHER INFORMATION CONTACT THE CLERK OF THE CIRCUIT COURT IMMEDIATELY AT THE COUNTY COURTHOUSE IN PENSACOLA, FLORIDA, OR CALL 850-595-3793.

NOTICE OF APPLICATION FOR TAX DEED

NOTICE IS HEREBY GIVEN, That **PRO TAX FINANCIAL LLC US BANK AS CUSTODIAN FOR PR** holder of **Tax Certificate No. 04786**, issued the **1st day of June, A.D., 2011** has filed same in my office and has made application for a tax deed to be issued thereon. Said certificate embraces the following described property in the County of Escambia, State of Florida, to wit:

LOT 13 BLK 2 1ST ADDN TO EDGEWATER PB 3 P 6 OR 3438 P 56 CA 180

SECTION 37, TOWNSHIP 2 S, RANGE 30 W

TAX ACCOUNT NUMBER 073926000 (16-006)

The assessment of the said property under the said certificate issued was in the name of

REBECCA ELLEN WATTS KENSELL and BOBBIE MARIE DELLINGER

Unless said certificate shall be redeemed according to law, the property described therein will be sold to the highest bidder at public auction at 9:00 A.M. on the **first Monday** in the month of January, which is the **4th day of January 2016**.

Dated this 3rd day of December 2015.

In accordance with the AMERICANS WITH DISABILITIES ACT, if you are a person with a disability who needs special accommodation in order to participate in this proceeding you are entitled to the provision of certain assistance. Please contact Emily Hogg not later than seven days prior to the proceeding at Escambia County Government Complex, 221 Palafox Place Ste 110, Pensacola FL 32502. Telephone: 850-595-3793.

Personal Services:

BOBBIE MARIE DELLINGER
338 EDGEWATER DR
PENSACOLA, FL 32507

PAM CHILDERS
CLERK OF THE CIRCUIT COURT
ESCAMBIA COUNTY, FLORIDA



By:
Emily Hogg
Deputy Clerk

ESCAMBIA COUNTY SHERIFF'S OFFICE
ESCAMBIA COUNTY, FLORIDA

16006

NON-ENFORCEABLE RETURN OF SERVICE

Document Number: ECSO15CIV055196NON

Agency Number: 16-002434

Court: TAX DEED

County: ESCAMBIA

Case Number: CERT # 04786 2011

Attorney/Agent:

PAM CHILDERS
CLERK OF COURT
TAX DEED

Plaintiff: IN RE REBECCA ELLEN WATTS KENSELL AND BOBBIE MARIE DELLINGER

Defendant:

Type of Process: NOTICE OF APPLICATION FOR TAX DEED

Substitute

Received this Writ on 12/3/2015 at 2:03 PM and served same on REBECCA ELLEN WATTS KENSELL , in ESCAMBIA COUNTY, FLORIDA, at 11:00 AM on 12/7/2015 by leaving a true copy of this Writ together with a copy of the initial pleadings, if any, with the date and hour of service endorsed thereon by me, at the within named individual's usual place of abode, with a person residing therein who is 15 years of age, or older, to wit: RICH KENSELL, HUSBAND, as a member of the household and informing said person of their contents.

DAVID MORGAN, SHERIFF
ESCAMBIA COUNTY, FLORIDA

By: _____

P. Wise 925

P. WISE, CPS

Service Fee: \$40.00

Receipt No: BILL

Printed By: DLRUPERT

WARNING

THERE ARE UNPAID TAXES ON PROPERTY WHICH YOU OWN OR IN WHICH YOU HAVE A LEGAL INTEREST. THE PROPERTY WILL BE SOLD AT PUBLIC AUCTION ON January 4, 2016, UNLESS THE TAXES ARE PAID. SHOULD YOU NEED FURTHER INFORMATION CONTACT THE CLERK OF THE CIRCUIT COURT IMMEDIATELY AT THE COUNTY COURTHOUSE IN PENSACOLA, FLORIDA, OR CALL 850-595-3793.

NOTICE OF APPLICATION FOR TAX DEED

NOTICE IS HEREBY GIVEN, That **PRO TAX FINANCIAL LLC US BANK AS CUSTODIAN FOR PR** holder of **Tax Certificate No. 04786**, issued the **1st day of June, A.D., 2011** has filed same in my office and has made application for a tax deed to be issued thereon. Said certificate embraces the following described property in the County of Escambia, State of Florida, to wit:

LOT 13 BLK 2 1ST ADDN TO EDGEWATER PB 3 P 6 OR 3438 P 56 CA 180

SECTION 37, TOWNSHIP 2 S, RANGE 30 W

TAX ACCOUNT NUMBER 073926000 (16-006)

The assessment of the said property under the said certificate issued was in the name of

REBECCA ELLEN WATTS KENSELL and BOBBIE MARIE DELLINGER

Unless said certificate shall be redeemed according to law, the property described therein will be sold to the highest bidder at public auction at 9:00 A.M. on the **first Monday** in the month of January, which is the **4th day of January 2016**.

Dated this 3rd day of December 2015.

In accordance with the AMERICANS WITH DISABILITIES ACT, if you are a person with a disability who needs special accommodation in order to participate in this proceeding you are entitled to the provision of certain assistance. Please contact Emily Hogg not later than seven days prior to the proceeding at Escambia County Government Complex, 221 Palafox Place Ste 110, Pensacola FL 32502. Telephone: 850-595-3793.

Personal Services:

REBECCA ELLEN WATTS KENSELL
338 EDGEWATER DR
PENSACOLA, FL 32507

PAM CHILDERS
CLERK OF THE CIRCUIT COURT
ESCAMBIA COUNTY, FLORIDA



By:
Emily Hogg
Deputy Clerk

PAM CHILDERS
 CLERK OF THE CIRCUIT COURT
 ARCHIVES AND RECORDS
 CHILDSUPPORT
 CIRCUIT CIVIL
 CIRCUIT CRIMINAL
 COUNTY CIVIL
 COUNTY CRIMINAL
 DOMESTIC RELATIONS
 FAMILY LAW
 JURY ASSEMBLY
 JUVENILE
 MENTAL HEALTH
 MIS
 OPERATIONAL SERVICES
 PROBATE
 TRAFFIC

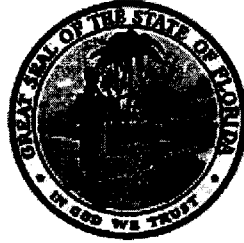

**COUNTY OF ESCAMBIA
 OFFICE OF THE
 CLERK OF THE CIRCUIT COURT**

**BRANCH OFFICES
 ARCHIVES AND RECORDS
 JUVENILE DIVISION
 CENTURY**

CLERK TO THE BOARD OF
 COUNTY COMMISSIONERS
 OFFICIAL RECORDS
 COUNTY TREASURY
 AUDITOR

**PAM CHILDERS, CLERK OF THE CIRCUIT COURT
 Tax Certificate Redeemed From Sale
 Account: 073926000 Certificate Number: 004786 of 2011**

Payor: Gary Gable 602 Edgewater Dr Pensacola, FL 32507 Date 12/17/2015

Clerk's Check #	437839528	Clerk's Total	\$492.20
Tax Collector Check #	1	Tax Collector's Total	\$5,572.79
		Postage	\$33.65
		Researcher Copies	\$1.00
		Total Received	\$6,099.64

**PAM CHILDERS
 Clerk of the Circuit Court**

Received By: _____
 Deputy Clerk

**Escambia County Government Complex • 221 Palafox Place Ste 110 • PENSACOLA, FLORIDA 32502
 (850) 595-3793 • FAX (850) 595-4827 • <http://www.clerk.co.escambia.fl.us>**

PAM CHILDERS
 CLERK OF THE CIRCUIT COURT
 ARCHIVES AND RECORDS
 CHILDSUPPORT
 CIRCUIT CIVIL
 CIRCUIT CRIMINAL
 COUNTY CIVIL
 COUNTY CRIMINAL
 DOMESTIC RELATIONS
 FAMILY LAW
 JURY ASSEMBLY
 JUVENILE
 MENTAL HEALTH
 MIS
 OPERATIONAL SERVICES
 PROBATE
 TRAFFIC

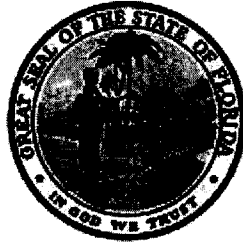

BRANCH OFFICES
ARCHIVES AND RECORDS
JUVENILE DIVISION
CENTURY

CLERK TO THE BOARD OF
 COUNTY COMMISSIONERS
 OFFICIAL RECORDS
 COUNTY TREASURY
 AUDITOR

COUNTY OF ESCAMBIA
OFFICE OF THE
CLERK OF THE CIRCUIT COURT

Case # 2011 TD 004786

Redeemed Date 12/17/2015

Name Gary Gable 602 Edgewater Dr Pensacola, FL 32507

Clerk's Total = TAXDEED	\$492.20
Due Tax Collector = TAXDEED	\$5,572.79
Postage = TD2	\$33.65
ResearcherCopies = TD6	\$1.00

• For Office Use Only

Date	Docket	Desc	Amount Owed	Amount Due	Payee Name
------	--------	------	-------------	------------	------------

No Information Available - See Dockets



PAM CHILDERS
CLERK OF THE CIRCUIT COURT
ESCAMBIA COUNTY, FLORIDA

Tax Deed - Redemption Calculator
Account: 073926000 Certificate Number: 004786 of 2011

Redemption Yes
 Application Date 10/13/2015
 Interest Rate 18%

	Final Redemption Payment ESTIMATED	Redemption Overpayment ACTUAL
	Auction Date <u>01/04/2016</u>	Redemption Date <u>12/17/2015</u>
Months	3	2
Tax Collector	\$5,326.83	\$5,326.83
Tax Collector Interest	\$239.71	\$159.80
Tax Collector Fee	\$6.25	\$6.25
Total Tax Collector	\$5,572.79	\$5,492.88 <i>TC</i>
Clerk Fee	\$130.00	\$130.00
Sheriff Fee	\$120.00	\$120.00
Legal Advertisement	\$221.00	\$221.00
App. Fee Interest	\$21.20	\$14.13
Total Clerk	\$492.20	\$485.13 <i>C4</i>
Postage	\$33.65	\$33.65
Researcher Copies	\$1.00	\$1.00
Total Redemption Amount	\$6,099.64	\$6,012.66
	Repayment Overpayment Refund Amount	\$86.98 <i>redeemer</i>

ACTUAL SHERIFF \$120.00
 (NO DATE) R. KENSELL SIGNED FOR BOBBIE MARIE DELLINGER AND
Notes REBECCA ELLEN WATTS KENSELL'S CERT MAIL. EBH



Pam Childers

Clerk of the Circuit Court and Comptroller, Escambia County

Clerk of Courts • County Comptroller • Clerk of the Board of County Commissioners • Recorder •

December 29, 2015

GARY GABLE
602 EDGEWATER DRIVE
PENSACOLA FL 32507

Dear Redeemer,

The records of this office show that an application for a tax deed had been made on the property represented by the numbered certificate listed below. The property was redeemed by you. A refund of unused fees/interest is enclosed.

If you have any questions, please feel free to give me a call.

CERTIFICATE NUMBER

REFUND

2011 TD 004786

\$86.98

TOTAL \$86.98

Very truly yours,

PAM CHILDERS
Clerk of Circuit Court

By:

A handwritten signature in black ink, appearing to read "Emily Hogg".

Emily Hogg
Tax Deed Division



Pam Childers

Clerk of the Circuit Court and Comptroller, Escambia County

Clerk of Courts • County Comptroller • Clerk of the Board of County Commissioners • Recorder •

December 29, 2015

PRO TAX FINANCIAL LLC US BANK AS CUSTODIAN FOR PR
360 SOUTH TECHNOLOGY COURT SUITE 100
LINDON UT 84042

Dear Certificate Holder:

The records of this office show that an application for a tax deed had been made on the property represented by the numbered certificate listed below. The property redeemed prior to sale; therefore your application fees are now refundable.

TAX CERT	APP FEES	INTEREST	TOTAL
2013 TD 001572	\$471.00	\$14.13	\$485.13
2011 TD 004786	\$471.00	\$14.13	\$485.13
2013 TD 010072	\$471.00	\$14.13	\$485.13
2013 TD 003728	\$471.00	\$14.13	\$485.13
2013 TD 002926	\$471.00	\$14.13	\$485.13
		TOTAL	\$2,425.65

Very truly yours,

PAM CHILDERS
Clerk of Circuit Court

By:

Emily Hogg
Tax Deed Division

THE ESCAMBIA SUN-PRESS, LLC
PUBLISHED WEEKLY SINCE 1948



(Warrington) Pensacola, Escambia County, Florida

STATE OF FLORIDA

County of Escambia

Before the undersigned authority personally appeared

MICHAEL P. DRIVER

who is personally known to me and who on oath says that he is Publisher of The Escambia Sun Press, a weekly newspaper published at (Warrington) Pensacola in Escambia County, Florida; that the attached copy of advertisement, being a

NOTICE in the matter of SALE

01/04/2016 - TAX CERTIFICATE # 04786

in the CIRCUIT Court
published in said newspaper in the issues of

DECEMBER 3, 10, 17, 24, 2015

Affiant further says that the said Escambia Sun-Press is a newspaper published at (Warrington) Pensacola, in said Escambia County, Florida, and that the said newspaper has heretofore been continuously published in said Escambia County, Florida each week and has been entered as second class mail matter at the post office in Pensacola, in said Escambia County, Florida, for a period of one year next preceding the first publication of the attached copy of advertisement; and affiant further says that he has neither paid nor promised any person, firm or corporation any discount, rebate, commission or refund for the purpose of securing this advertisement for publication in the said newspaper.

[Signature]

PUBLISHER

Sworn to and subscribed before me this 24TH DAY OF
DECEMBER A.D., 2015

[Signature]

PAULA D. TURNER

NOTARY PUBLIC

NOTICE OF APPLICATION FOR
TAX DEED

NOTICE IS HEREBY GIVEN, That PRO TAX FINANCIAL LLC US BANK AS CUSTODIAN FOR PR holder of Tax Certificate No. 04786, issued the 1st day of June, A.D., 2011 has filed same in my office and has made application for a tax deed to be issued thereon. Said certificate embraces the following described property in the County of Escambia, State of Florida, to wit:

LOT 13 BLK 2 1ST ADDN TO EDGEWATER PB 3 P 6 OR 3438 P 56 CA 180

SECTION 37, TOWNSHIP 2 S, RANGE 30 W

TAX ACCOUNT NUMBER 073926000

The assessment of the said property under the said certificate issued was in the name of REBECCA ELLEN WATTS KENSELL and BOBBIE MARIE DELLINGER

Unless said certificate shall be redeemed according to law, the property described therein will be sold to the highest bidder at public auction at 9:00 A.M. on the first Monday in the month of January, which is the 4th day of January 2016.

Dated this 3rd day of December 2015.

In accordance with the AMERICANS WITH DISABILITIES ACT, if you are a person with a disability who needs special accommodation in order to participate in this proceeding you are entitled to the provision of certain assistance. Please contact Emily Hogg not later than seven days prior to the proceeding at Escambia County Government Complex, 221 Palafox Place Ste 110, Pensacola FL 32502. Telephone: 850-595-3793.

PAM CHILDERS
CLERK OF THE CIRCUIT COURT
ESCAMBIA COUNTY, FLORIDA
(SEAL)

By: Emily Hogg
Deputy Clerk

oaw-4w-12-03-10-17-24-2015

