

## Notice to Tax Collector of Application for Tax Deed

### TO: Tax Collector of Escambia County

In accordance with Florida Statutes, I,

**WELLS FARGO BANK OBO TAX LIENS  
SECURITIZATION TRUS  
PO BOX 741307  
ATLANTA, Georgia, 30384-1307**

holder of the following tax sale certificate hereby surrender same to the Tax Collector and make tax deed application thereon:

<b>Certificate No.</b>	<b>Parcel ID Number</b>	<b>Date</b>	<b>Legal Description</b>
9658	11-4494-220	06/01/2010	37-1N3-114 BEG AT SW COR OF S 1/2 OF SE 1/4 OF NE 1/4 N 357 92/100 FT E 658 FOR POB CONT ON SAME COURSE 125 FT N 295 30/100 FT W 125 FT S295 45/100 FT TO POB BEING LOT 13 UNRECORDED PLAT OR 1584 P 424

### **2011 TAX ROLL**

DONALDSON SUSAN VALE BRASWELL  
442 TALL PINES RD  
CANTONMENT , Florida 32533

I agree to pay all delinquent taxes, redeem all outstanding certificates not in my possession, pay any omitted taxes, and pay current taxes, if due, covering the land, and pay any interest earned (a) on tax certificates not in my possession, (b) on omitted taxes or (c) on delinquent taxes. I also agree to pay all Tax Collector's fees, ownership and encumbrance reports costs, Clerk of the Court costs, charges and fees and Sheriff's costs, if applicable. Attached is the above-mentioned tax sale certificate on which this application is based and all other certificates of the same legal description which are in my possession.

wfremic10 (Shane Leach)

Applicant's Signature

04/26/2012

Date

FORM 513  
(r.12/00)

**TAX COLLECTOR'S CERTIFICATION**

**APPLICATION DATE**

4/26/2012

**FULL LEGAL DESCRIPTION**  
**Parcel ID Number: 11-4494-220**

May 11, 2012  
Tax Year: 2009  
Certificate Number: 9658

BEG AT SW COR OF S 1/2 OF SE 1/4 OF NE 1/4 N 357 92/100 FT E 658 FOR POB CONT ON SAME COURSE 125 FT  
N 295 30/100 FT W 125 FT S295 45/100 FT TO POB BEING LOT 13 UNRECORDED PLAT OR 1584 P 424

**TAX COLLECTOR'S CERTIFICATION**

**Application  
Date / Number  
Apr 26, 2012 / 120364**

This is to certify that the holder listed below of Tax Sale Certificate Number **2010 / 9658** , issued the **1st day of June, 2010**, and which encumbers the following described property located in the County of Escambia, State of Florida to wit: **Parcel ID Number: 11-4494-220**

**Certificate Holder:**

WELLS FARGO BANK OBO TAX LIENS SECURITIZATION TRUS  
PO BOX 741307  
ATLANTA, GEORGIA 30384-1307

**Property Owner:**

DONALDSON SUSAN VALE BRASWELL  
442 TALL PINES RD  
CANTONMENT , FLORIDA 32533

**Legal Description: 37-1N3-114**

BEG AT SW COR OF S 1/2 OF SE 1/4 OF NE 1/4 N 357 92/100 FT E 658 FOR POB CONT ON SAME COURSE 125 FT N 295 30/100 FT W 125 FT S295 45/100 FT TO POB BE ...

**See attachment for full legal description.**

has surrendered same in my office and made written application for tax deed in accordance with Florida Statutes. I certify that the following tax certificates, interest, ownership and encumbrance report fee, and Tax Collector's fees have been paid:

**CERTIFICATES OWNED BY APPLICANT AND FILED IN CONNECTION WITH THIS TAX DEED APPLICATION:**

Cert. Year	Certificate Number	Date of Sale	Face Amt	T/C Fee	Interest	Total
2010	9658	06/01/10	\$814.52	\$0.00	\$74.15	\$888.67

**CERTIFICATES REDEEMED BY APPLICANT OR INCLUDED (COUNTY) IN CONNECTION WITH THIS APPLICATION:**

Cert. Year	Certificate Number	Date of Sale	Face Amt	T/C Fee	Interest	Total
2011	9379.0000	06/01/11	\$856.23	\$6.25	\$42.81	\$905.29
2009	8990	06/01/09	\$804.32	\$6.25	\$422.27	\$1,232.84

1. Total of all Certificates in Applicant's Possession and Cost of the Certificates Redeemed by Applicant or Included (County)
2. Total of Delinquent Taxes Paid by Tax Deed Application
3. Total of Current Taxes Paid by Tax Deed Applicant (2011)
4. Ownership and Encumbrance Report Fee
5. Tax Deed Application Fee
6. Total Certified by Tax Collector to Clerk of Court
7. Clerk of Court Statutory Fee
8. Clerk of Court Certified Mail Charge
9. Clerk of Court Advertising Charge
10. Sheriff's Fee
11. \_\_\_\_\_
12. Total of Lines 6 thru 11
13. Interest Computed by Clerk of Court Per Florida Statutes.....( %)
14. One-Half of the assessed value of homestead property. If applicable pursuant to section 197.502, F.S.
15. Statutory (Opening) Bid; Total of Lines 12 thru 14
16. Redemption Fee
17. Total Amount to Redeem

\$3,026.80
\$0.00
\$811.04
\$150.00
\$75.00
\$4,062.84
\$4,062.84
\$41,490.00
\$6.25

\*Done this 26th day of April, 2012

TAX COLLECTOR, ESCAMBIA COUNTY, FLORIDA

By \_\_\_\_\_

*Glenda Makuron*

Date of Sale: \_\_\_\_\_

*January 7, 2013*

\* This certification must be surrendered to the Clerk of the Circuit Court no later than ten days after this date.

**ERNIE LEE MAGAHA**  
CLERK OF THE CIRCUIT COURT



BRANCH OFFICES  
ARCHIVES AND RECORDS  
JUVENILE DIVISION

CENTURY

ARCHIVES AND RECORDS  
CHILD SUPPORT  
CIRCUIT CIVIL  
CIRCUIT CRIMINAL  
COUNTY CIVIL  
COUNTY CRIMINAL  
DOMESTIC RELATIONS  
FAMILY LAW  
JURY ASSEMBLY  
JUVENILE  
MENTAL HEALTH  
MIS  
OPERATIONAL SERVICES  
PROBATE  
TRAFFIC

**COUNTY OF ESCAMBIA  
OFFICE OF THE  
CLERK OF THE CIRCUIT COURT**

CLERK TO THE BOARD OF  
COUNTY COMMISSIONERS

OFFICIAL RECORDS  
COUNTY TREASURY  
AUDITOR

## IMAGING COVER PAGE

This cover page is not a part of the original documents but is necessary to avoid obscuring any information on the original documents

---

Case: 2010 TD 009658



00021344339

Dkt: TD83 Pg#:

---

4

**Original Documents Follow**

FILE NO. T-26756-C  
DOC. \$32.40  
SUR.  
REC. \$4.00

# WARRANTY DEED

STATE OF FLORIDA

COUNTY OF ESCAMBIA

1057 West Nine Mile Road Pensacola FL 32504

Grantor's Address

KNOW ALL MEN BY THESE PRESENTS: That LESLIE A. PHIPPS and SANDRA S. PHIPPS, husband and wife

Grantor for and in consideration of Ten Dollars (\$10.00) and other good and valuable considerations the receipt of which is hereby acknowledged has bargained, sold, conveyed and granted unto SUSAN VALE BRASWELL

grantee's heirs, executors, administrators and assigns, forever, the following described property, situate, lying and being in the County of ESCAMBIA, State of Florida, to wit:

Lot 13 of an unrecorded plat, beginning at the Southwest corner of the South half of the Southeast quarter of the Northeast quarter, Section 37, Township 1 North, Range 31 West, Escambia County, Florida; thence North 357.92 feet, thence East 658 feet to the point of beginning, thence continue on same course 125 feet, thence North 295.30 feet, thence West 125 feet, thence South 295.45 feet to the point of beginning.

This instrument prepared by  
Rhonda H. Sewell  
312 So. Baylen St.

Approved on of Chelsea  
Title & Guaranty Co.  
Pursuant to the issuance  
of a Title Insurance Policy

107032  
OCT 9 3 01 PM '81  
RECORDED IN PUBLIC RECORDS OF ESCAMBIA COUNTY FLORIDA

Said grantor does fully warrant the title to said land and will defend the same against the lawful claims of all persons whomsoever.

Whenever used herein, the term "grantee/grantor" shall include the heirs, personal representatives, successors and/or assigns of the respective parties hereto, the use of singular gender shall include the plural, and the plural the singular, the use of any gender shall include all genders.

IN WITNESS WHEREOF, grantor has hereunto set grantor's hand and seal on October 9, 1981.

Signed, sealed and delivered in the presence of

*John P. ...*  
*Rhonda H. Sewell*

*Leslie A. Phipps* (SEAL)  
*Sandra S. Phipps* (SEAL)  
(SEAL)  
(SEAL)

STATE OF FLORIDA  
COUNTY OF ESCAMBIA

The foregoing instrument was acknowledged before me this October 9, 1981 by LESLIE A. PHIPPS and SANDRA S. PHIPPS, husband and wife

ESCAMBIA COUNTY  
020271  
STATE OF FLORIDA  
DOCUMENTARY STAMP TAX  
DEPT. OF REVENUE  
PA 00 OCT 12 1981  
32.40

*Donald W. ...*  
Notary Public  
(Notary Seal) 6/11/82  
My Commission Expires

# SOUTHERN GUARANTY TITLE COMPANY

4400 BAYOU BLVD., SUITE 13-B, CORDOVA SQUARE

PENSACOLA, FLORIDA 32503

TEL. (850) 478-8121 FAX (850) 476-1437

Email: rcsrgt@aol.com

Janet Holley  
Escambia County Tax Collector  
P.O. Box 1312  
Pensacola, FL 32596

CERTIFICATION: TITLE SEARCH FOR TDA

TAX DEED SALE DATE: 1-7-2013

TAX ACCOUNT NO.: 11-4494-220

CERTIFICATE NO.: 2010-9658

In compliance with Section 197.256, Florida Statutes, the following is a list of names and addresses of those persons, firms and/or agencies having legal interest in or claim against the above described property. The above referenced tax sale certificate is being submitted as proper notification of tax deed sale.

YES NO

      X   Notify City of Pensacola, P.O. Box 12910, 32521

      X   Notify Escambia County, 190 Governmental Center, 32502

  X       Homestead for 2011 tax year.

Susan V. Donaldson fka  
Susan Vale Braswell  
442 Tall Pines Rd.  
Cantonment, FL 32533

Certified and delivered to Escambia County Tax Collector,  
this 24th day of July, 2012.

SOUTHERN GUARANTY TITLE COMPANY

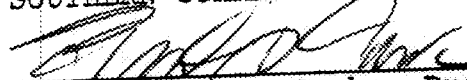
  
by: Richard S. Combs, President

NOTE: The above listed addresses are based upon current information available, but said addresses are not guaranteed to be true or correct.

**OWNERSHIP AND ENCUMBRANCE REPORT  
CONTINUATION PAGE**

File No.: 9598

July 20, 2012

UNSATISFIED MORTGAGES, LIENS AND JUDGMENTS AFFECTING THE LAND COVERED BY THIS REPORT THAT APPEAR OF RECORD:

1. Taxes for the year 2008-2011 delinquent. The assessed value is \$82,980.00. Tax ID 11-4494-220.

PLEASE NOTE THE FOLLOWING:

- A. Taxes and assessments due now or in subsequent years.
- B. Subject to Easements, Restrictions and Covenants of record.
- C. Oil, gas, mineral or any other subsurface rights of any kind or nature.
- D. Encroachments, overlaps, boundary line disputes, and any other matters which would be disclosed by an accurate survey and inspection of the premises.

**OWNERSHIP AND ENCUMBRANCE REPORT  
LEGAL DESCRIPTION**

File No.: 9598

July 20, 2012

**371N311403000013 - Full Legal Description**

BEG AT SW COR OF S 1/2 OF SE 1/4 OF NE 1/4 N 357 92/100 FT E 658 FOR POB CONT ON  
SAME COURSE 125 FT N 295 30/100 FT W 125 FT S 295 45/100 FT TO POB BEING LOT 13  
UNRECORDED PLAT OR 1584 P 424



**Southern Guaranty Title Company**

4400 Bayou Boulevard, Suite 13B  
Pensacola, Florida 32503  
Telephone: 850-478-8121  
Facsimile: 850-476-1437

**OWNERSHIP AND ENCUMBRANCE REPORT**

File No.: 9598

July 20, 2012

Escambia County Tax Collector  
P.O. Box 1312  
Pensacola, Florida 32569

Pursuant to your request, the Company has caused a search to be made of the Public Records of Escambia County, Florida, solely as revealed by records maintained from 07-20-1992, through 07-20-2012, and said search reveals the following:

1. THE GRANTEE(S) OF THE LAST DEED(S) OF RECORD IS:

Susan V. Donladson FKA Susan Vale Brsswell

2. The land covered by this Report is:

LEGAL DESCRIPTION IS ATTACHED HERETO AND MADE A PART HEREOF

3. The following unsatisfied mortgages, liens and judgments affecting the land covered by this Report appear of record:

SEE CONTINUATION PAGE ATTACHED HERETO AND MADE A PART HEREOF

4. Taxes:

SEE CONTINUATION PAGE ATTACHED HERETO AND MADE A PART HEREOF

The foregoing report is prepared and furnished for information only, is not intended to constitute or imply any opinion, warranty, guaranty, insurance, or similar assurance as to the status of title, and no determination has been made of the authenticity of any instrument described or referred to herein. The name search for the purposes of determining applicable judgments and liens is limited to the apparent record owner(s) shown herein. No attempt has been made to determine whether the land is subject to liens or assessments which are not shown as existing liens by the public records. The Company's liability hereunder shall not exceed the cost of this Report, or \$1,000.00 whichever is less.

THIS REPORT SHALL NOT BE USED FOR THE ISSUANCE OF TITLE INSURANCE.

Southern Guaranty Title Company

By: 

July 20, 2012

**ERNIE LEE MAGAHA**  
CLERK OF THE CIRCUIT COURT



**BRANCH OFFICES**  
ARCHIVES AND RECORDS  
JUVENILE DIVISION

CENTURY

ARCHIVES AND RECORDS  
CHILD SUPPORT  
CIRCUIT CIVIL  
CIRCUIT CRIMINAL  
COUNTY CIVIL  
COUNTY CRIMINAL  
DOMESTIC RELATIONS  
FAMILY LAW  
JURY ASSEMBLY  
JUVENILE  
MENTAL HEALTH  
MIS  
OPERATIONAL SERVICES  
PROBATE  
TRAFFIC

**COUNTY OF ESCAMBIA**  
**OFFICE OF THE**  
**CLERK OF THE CIRCUIT COURT**

CLERK TO THE BOARD OF  
COUNTY COMMISSIONERS

OFFICIAL RECORDS  
COUNTY TREASURY  
AUDITOR

**IMAGING COVER PAGE**

This cover page is not a part of the original documents but is  
necessary to avoid obscuring any information on  
the original documents

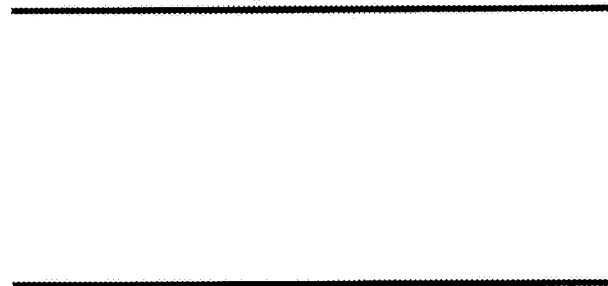

6

**Original Documents Follow**

**Buildings**

Building 1 - Address: 442 TALL PINES LN, Year Built: 1984, Effective Year: 1984

**Structural Elements**

**FOUNDATION-SLAB ON GRADE**

**EXTERIOR WALL-SIDING-LAP.AAVG**

**NO. PLUMBING FIXTURES-6.00**

**DWELLING UNITS-1.00**

**ROOF FRAMING-GABLE**

**ROOF COVER-ENAMEL METAL**

**INTERIOR WALL-DRYWALL-PLASTER**

**FLOOR COVER-CARPET**

**NO. STORIES-1.00**

**FLOOR COVER-TILE/STAIN**

**CONC/BRICK**

**DECOR/MILLWORK-AVERAGE**

**HEAT/AIR-CENTRAL H/AC**

**STRUCTURAL FRAME-WOOD**

**FRAME**

**Areas - 2437 Total SF**

**BASE AREA - 2077**

**OPEN PORCH FIN - 120**

**OPEN PORCH UNF - 240**

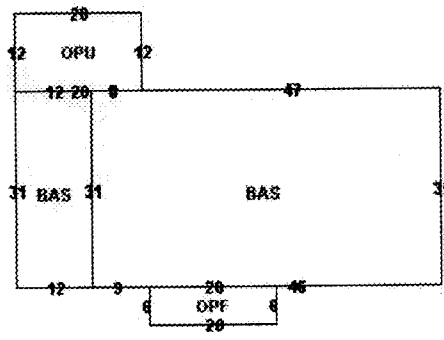

**Images**

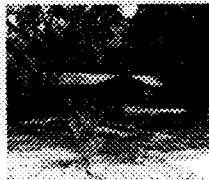

7/6/11

The primary use of the assessment data is for the preparation of the current year tax roll. No responsibility or liability is assumed for inaccuracies or errors.



# Chris Jones Escambia County Property Appraiser

[Real Estate Search](#) | [Tangible Property Search](#) | [Amendment 1 Calculations](#)

[Back](#)

[Navigate Mode](#)  [Account](#)  
 [Reference](#)

[Printer Friendly Version](#)

General Information	
<b>Reference:</b>	371N311403000013
<b>Account:</b>	114494220
<b>Owners:</b>	DONALDSON SUSAN VALE BRASWELL
<b>Mail:</b>	442 TALL PINES RD CANTONMENT, FL 32533
<b>Situs:</b>	442 TALL PINES LN 32533
<b>Use Code:</b>	SINGLE FAMILY RESID <input type="checkbox"/>
<b>Taxing Authority:</b>	COUNTY MSTU
<b>Tax Inquiry:</b>	<a href="#">Open Tax Inquiry Window</a>
Tax Inquiry link courtesy of Janet Holley, Escambia County Tax Collector	

2011 Certified Roll Assessment	
<b>Improvements:</b>	\$89,572
<b>Land:</b>	\$19,380
<b>Total:</b>	\$108,952
<b>Save Our Homes:</b>	\$82,980
<a href="#">Disclaimer</a>	
<a href="#">Amendment 1 Calculations</a>	

Sales Data					Official Records (New Window)
<b>Sale Date</b>	<b>Book</b>	<b>Page</b>	<b>Value</b>	<b>Type</b>	<a href="#">View Instr</a>
10/1981	1584	424	\$7,200	WD	<a href="#">View Instr</a>
01/1978	1201	154	\$5,500	WD	<a href="#">View Instr</a>
Official Records Inquiry courtesy of Ernie Lee Magaha, Escambia County Clerk of the Court					

2011 Certified Roll Exemptions	
HOMESTEAD EXEMPTION	
<b>Legal Description</b>	<input type="checkbox"/>
BEG AT SW COR OF S 1/2 OF SE 1/4 OF NE 1/4 N 357 92/100 FT E 658 FOR POB CONT ON SAME COURSE 125 FT...	
<b>Extra Features</b>	<input type="checkbox"/>
FRAME BUILDING POOL	

**Parcel Information** [Restora Map](#) [Get Map Image](#) [Launch Interactive Map](#)

**Section Map Id:**  
37-1N-31

**Approx. Acreage:**  
0.8500

**Zoned:**   
VR-2

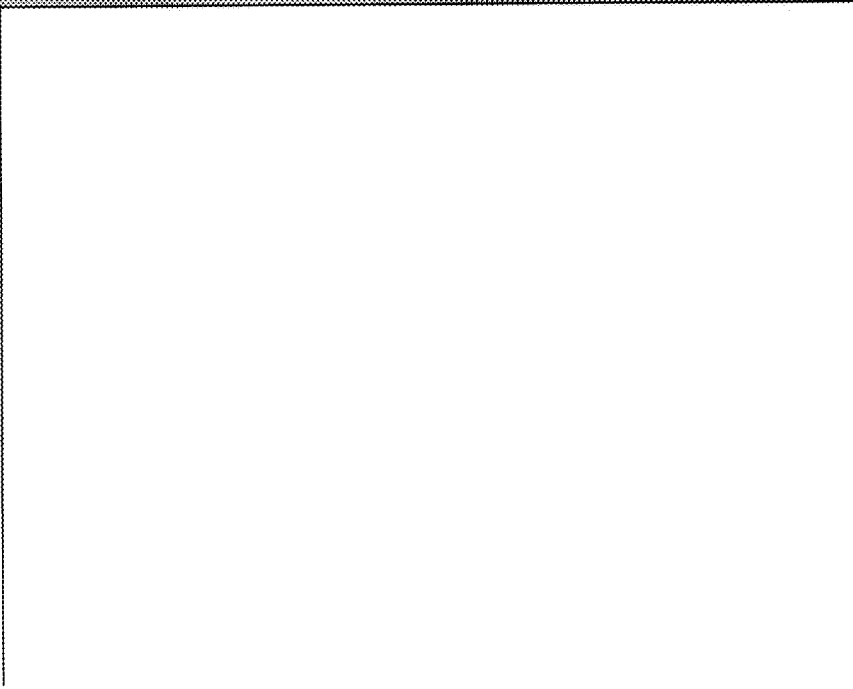

Ernie Lee Magaha,  
Clerk of the Circuit Court of Escambia County Florida

Receipt Type Case Outstanding Amount 0.00  
Receipt Number 1415900 Receipt Date 05/24/2012

Case Number 2010 TD 009658  
Description WELLS FARGO BANK OBO TAX LIENS VS

Action TAX DEED APPLICATION

Judge

Received From WELLS FARGO BANK OBO TAX LIENS

On Behalf Of WELLS FARGO BANK OBO TAX LIENS

Total Received	401.00
Net Received	401.00
Change	0.00

Receipt Payments	Amount	Reference Description
Cash	401.00	ONCORE TRANS#938283

Receipt Applications	Amount
Holding	341.00
Service Charge	60.00

Deputy Clerk: mavila Transaction Date 05/24/2012 15:16:10

Comments

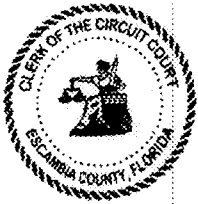

ERNIE LEE MAGAHA  
 Clerk of the Circuit Court  
 Escambia County, FL  
 P.O. Box 333  
 Pensacola, FL 32591  
 850-595-3930

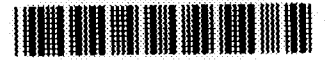

**Print Date:**  
 5/24/2012 3:15:30 PM

Transaction #: 938283  
 Receipt #: 201231744  
 Cashier Date: 5/24/2012 3:15:29 PM (MAVILA)

Customer Information	Transaction Information	Payment Summary
(TXD) TAX DEED DIVISION CLERK OF THE CIRCUIT COURT 221 PALAFOX PLACE Pensacola, FL 32502	Date Received: 05/24/2012 Source Code: Over the Counter Q Code: Return Code: Government Trans Type: Recording Agent Ref Num:	Total Fees \$401.00 Total Payments \$401.00

1 Payments		
 CLERK		\$401.00

0 Recorded Items		
------------------	--	--

0 Search Items		
----------------	--	--

1 Miscellaneous Items		
 (MISCFEE) MISCELLANEOUS FEES TAX CERT#09658 OF 2010		
TAXCR	341	\$341.00
TAXCT	1	\$60.00

**ERNIE LEE MAGAHA**  
 CLERK OF THE CIRCUIT COURT  
 ARCHIVES AND RECORDS  
 CHILDSUPPORT  
 CIRCUIT CIVIL  
 CIRCUIT CRIMINAL  
 COUNTY CIVIL  
 COUNTY CRIMINAL  
 DOMESTIC RELATIONS  
 FAMILY LAW  
 JURY ASSEMBLY  
 JUVENILE  
 MENTAL HEALTH  
 MIS  
 OPERATIONAL SERVICES  
 PROBATE  
 TRAFFIC



**BRANCH OFFICES**  
**ARCHIVES AND RECORDS**  
**JUVENILE DIVISION**  
**CENTURY**

CLERK TO THE BOARD OF  
 COUNTY COMMISSIONERS  
 OFFICIAL RECORDS  
 COUNTY TREASURY  
 AUDITOR

**COUNTY OF ESCAMBIA**  
**OFFICE OF THE**  
**CLERK OF THE CIRCUIT COURT**

**Case # 2010 TD 009658**  
**Redeemed Date 09/27/2012**

**Name SUSAN V DONALDSON 442 TALL PINES RD CANTONMENT, FL 32533**

Clerk's Total = TAXDEED	\$455.14
Due Tax Collector = TAXDEED	\$4,617.57
Postage = TD2	\$6.00
ResearcherCopies = TD6	\$5.00

**Apply Docket Codes**

• For Office Use Only

Date	Docket	Desc	Amount Owed	Amount Due	Payee Name
06/01/2010	TAXDEED	TAX DEED CERTIFICATES Receipt: 1415900 Date: 05/24/2012	341.00	0.00	
06/01/2010	TD1	TAX DEED APPLICATION Receipt: 1415900 Date: 05/24/2012	60.00	0.00	
06/06/2012	TD83	TAX COLLECTOR CERTIFICATION	0.00	0.00	
09/27/2012	TD6	TITLE RESEARCHER COPY CHARGES	5.00	5.00	
09/27/2012	TAXDEED	TAXDEED Due Tax Collector	4,617.57	4,617.57	
09/27/2012	TD2	POSTAGE TAX DEEDS	6.00	6.00	
09/27/2012	TAXDEED	TAXDEED Clerk's Total	455.14	455.14	

**FINANCIAL SUMMARY**

Rcd	Docket Application	Owed	Paid	Dismissed	Due
1	Service Charge	\$71.00	\$60.00	\$0.00	\$11.00
2	Holding	\$5,413.71	\$341.00	\$0.00	\$5,072.71
	<b>TOTAL</b>	<b>\$5,484.71</b>	<b>\$401.00</b>	<b>\$0.00</b>	<b>\$5,083.71</b>

THIS DOCUMENT HAS AN ARTIFICIAL WATERMARK PRINTED ON THE BACK. THE FRONT OF THE DOCUMENT HAS A MICRO-PRINT SIGNATURE LINE. ABSENCE OF THESE FEATURES WILL INDICATE A COPY.

**SPCE Credit Union**  
*"We're Here For You!"*

WHITNEY NATIONAL BANK  
PENSACOLA, FLORIDA

639590632

Cashier Check

**027067**

OFFICIAL CHECK

027067

DATE SEP 27 12

PAY

Five thousand and 00/100\*\*\*\*\* \$5,000.00

TO  
THE  
ORDER  
OF

ESCAMBIA COUNTY TAX COLLECTOR  
FROM: SUSAN V DONALDSON  
FOR : TAXES FOR 42 TALL PINES

*Amanda Hubbsmud*

VOID AFTER 60 DAYS

NORTH OFFICE PENSACOLA, FL.

⑈027067⑈ ⑆063209505⑆ 730141470⑈



**ERNIE LEE MAGAHA**  
 CLERK OF THE CIRCUIT COURT  
 ARCHIVES AND RECORDS  
 CHILDSUPPORT  
 CIRCUIT CIVIL  
 CIRCUIT CRIMINAL  
 COUNTY CIVIL  
 COUNTY CRIMINAL  
 DOMESTIC RELATIONS  
 FAMILY LAW  
 JURY ASSEMBLY  
 JUVENILE  
 MENTAL HEALTH  
 MIS  
 OPERATIONAL SERVICES  
 PROBATE  
 TRAFFIC

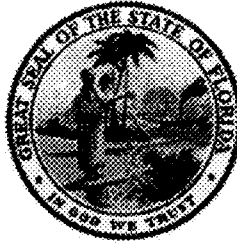

**BRANCH OFFICES**  
**ARCHIVES AND RECORDS**  
**JUVENILE DIVISION**  
**CENTURY**

CLERK TO THE BOARD OF  
 COUNTY COMMISSIONERS  
 OFFICIAL RECORDS  
 COUNTY TREASURY  
 AUDITOR

**COUNTY OF ESCAMBIA**  
**OFFICE OF THE**  
**CLERK OF THE CIRCUIT COURT**

**ERNIE LEE MAGAHA, CLERK OF THE CIRCUIT COURT**  
**Tax Certificate Redeemed From Sale**  
**Account: 114494220 Certificate Number: 009658 of 2010**

**Payor: SUSAN V DONALDSON 442 TALL PINES RD CANTONMENT, FL 32533**      **Date**  
 09/27/2012

Clerk's Check #	27067	Clerk's Total	\$455.14
Tax Collector Check #	1	Tax Collector's Total	\$4,617.57
		Postage	\$6.00
		Researcher Copies	\$5.00
		<b>Total Received</b>	<b>\$5,083.71</b>

**ERNIE LEE MAGAHA**  
 Clerk of the Circuit Court

Received By: *[Signature]*  
 Deputy Clerk

Ernie Lee Magaha,  
Clerk of the Circuit Court of Escambia County Florida

Receipt Type Case Outstanding Amount 0.00  
Receipt Number 1456657 Receipt Date 09/27/2012

Case Number 2010 TD 009658

Description WELLS FARGO BANK OBO TAX LIENS VS

Action TAX DEED REDEMPTION

Judge

Received From SUSAN DONALDSON

On Behalf Of WELLS FARGO BANK OBO TAX LIENS

Total Received	5,083.71
Net Received	5,083.71
Change	0.00

Receipt Payments	Amount	Reference	Description
Check	5,000.00	027067	
Cash	83.71	CASH	

Receipt Applications	Amount
Holding	5,072.71
Service Charge	11.00

Deputy Clerk: mavila Transaction Date 09/27/2012 14:10:50

Comments



**ERNIE LEE MAGAHA**  
**CLERK OF THE CIRCUIT COURT**  
**ESCAMBIA COUNTY, FLORIDA**

**Tax Deed - Redemption Calculator**  
**Account: 114494220 Certificate Number: 009658 of 2010**

Redemption  Yes   
 Application Date    
 Interest Rate

	Final Redemption Payment ESTIMATED	Redemption Overpayment ACTUAL
	Auction Date <input type="text" value="01/07/2013"/>	Redemption Date <input type="text" value="09/27/2012"/>
Months	9	5
Tax Collector	<input type="text" value="\$4,062.84"/>	<input type="text" value="\$4,062.84"/>
Tax Collector Interest	\$548.48	\$304.71
Tax Collector Fee	<input type="text" value="\$6.25"/>	<input type="text" value="\$6.25"/>
Total Tax Collector	\$4,617.57	\$4,373.80
Clerk Fee	<input type="text" value="\$60.00"/>	<input type="text" value="\$60.00"/>
Sheriff Fee	<input type="text" value="\$120.00"/>	<input type="text" value="\$120.00"/>
Legal Advertisement	<input type="text" value="\$221.00"/>	<input type="text" value="\$221.00"/>
App. Fee Interest	\$54.14	\$30.08
Total Clerk	\$455.14	\$431.08
Postage	<input type="text" value="\$6.00"/>	<input type="text" value="\$6.00"/>
Researcher Copies	<input type="text" value="\$5.00"/>	<input type="text" value="\$5.00"/>
Total Redemption Amount	\$5,083.71	\$4,815.88
	Repayment Overpayment Refund Amount	\$267.83 + 120 + 221 = 608.83

**Notes**   
 ACTUAL SHERIFF \$80.00   
 COM FEE \$18.50  
 05/17/2012 Recd message to call Susan Donaldson 324-0712  
 (cell) or 434-4011 (office) to provide redemption quote.   
 Tel

THIS DOCUMENT IS PRINTED ON TONER ADHESION PAPER

**ERNIE LEE MAGAHA**  
CLERK OF THE COURT & COMPTROLLER  
P.O. BOX 333  
PENSACOLA, FL 32591-0333  
(850) 595-4140  
REGISTRY ACCOUNT



PENSACOLA, FLORIDA

63-27  
631

900001658

VOID AFTER 6 MONTHS

\*SIX HUNDRED EIGHT AND 83/100

PAY

SUSAN V DONALDSON

TO THE  
ORDER  
OF

SUSAN V DONALDSON  
442 TALL PINES RD  
CANTONMENT, FL 32533

DATE

AMOUNT

10/02/2012

608.83

*Ernie Lee Magaha*

ERNIE LEE MAGAHA, CLERK OF THE COURT

⑈9000016581⑈ ⑆063100277⑆ 898033991356⑈

**ERNIE LEE MAGAHA**  
CLERK OF THE COURT & COMPTROLLER

900001658

Date  
10/02/2012

Case Number  
2010 TD 009658

Description  
PAYMENT TAX DEEDS

Amount  
608.83

900001658

Check: 9000016581 10/02/2012 SUSAN V DONALDSON

Check Amount: 608.83

**ERNIE LEE MAGAHA**  
CLERK OF THE COURT & COMPTROLLER  
P.O. BOX 333  
PENSACOLA, FL 32591-0333  
(850) 595-4140  
REGISTRY ACCOUNT

Bank of America  
PENSACOLA, FLORIDA

63-27  
631

9000016586

VOID AFTER 6 MONTHS

PAY

\*EIGHT HUNDRED SIXTY TWO AND 16/100

WELLS FARGO BANK OBO TAX LIENS  
SECURITIZATION TRUST

DATE AMOUNT

TO THE  
ORDER  
OF

WELLS FARGO BANK OBO TAX LIENS SECURITIZATI  
P O BOX 741307  
ATLANTA, GA 30384

10/02/2012

862.16

*Ernie Lee Magaha*

ERNIE LEE MAGAHA, CLERK OF THE COURT



⑈9000016586⑈ ⑆063100277⑆ 898033991358⑈

**ERNIE LEE MAGAHA**  
CLERK OF THE COURT & COMPTROLLER

9000016586

<u>Date</u>	<u>Case Number</u>	<u>Description</u>	<u>Amount</u>
10/02/2012	2010 TD 009658	PAYMENT TAX DEEDS	431.08
10/02/2012	2010 TD 002233	PAYMENT TAX DEEDS	431.08

9000016586

Check: 9000016586 10/02/2012 WELLS FARGO BANK OBO TAX LIENS  
SECURITIZATION TRUST

Check Amount:

862.16

THIS DOCUMENT IS PRINTED ON TONER ADHESION PAPER

**ERNIE LEE MAGAHA**  
 CLERK OF THE COURT & COMPTROLLER  
 P.O. BOX 333  
 PENSACOLA, FL 32591-0333  
 (850) 595-4140  
 REGISTRY ACCOUNT

Bank of America  
 PENSACOLA, FLORIDA  
 VOID AFTER 6 MONTHS

63-27  
 631

90000165

PAY \*FIFTY ONE THOUSAND EIGHT HUNDRED SEVENTY SIX AND 08/100  
 JANET HOLLEY TAX COLLECTOR

TO THE ORDER OF JANET HOLLEY TAX COLLECTOR  
 213 PALAFOX PLACE  
 PENSACOLA, FL 32502

DATE AMOUNT  
 10/02/2012 51,876.08

*Ernie Lee Magaha*

ERNIE LEE MAGAHA, CLERK OF THE COURT

⑈9000016563⑈ ⑆063100277⑆ 898033991356⑈

**ERNIE LEE MAGAHA**  
 CLERK OF THE COURT & COMPTROLLER

90000165

Date	Case Number	Description	Amount
10/02/2012	2009 TD 001702	PAYMENT TAX DEEDS	1,060.35
10/02/2012	2009 TD 003043	PAYMENT TAX DEEDS	932.85
10/02/2012	2009 TD 002917	PAYMENT TAX DEEDS	2,851.18
10/02/2012	2009 TD 002899	PAYMENT TAX DEEDS	2,182.48
10/02/2012	2009 TD 002077	PAYMENT TAX DEEDS	3,922.29
10/02/2012	2009 TD 003105	PAYMENT TAX DEEDS	1,275.79
10/02/2012	2009 TD 009682	PAYMENT TAX DEEDS	1,222.87
10/02/2012	2009 TD 003633	PAYMENT TAX DEEDS	2,408.13
10/02/2012	2010 TD 007562	PAYMENT TAX DEEDS	3,303.72
10/02/2012	2009 TD 003658	PAYMENT TAX DEEDS	4,469.41

There are additional check details for this check that total:

28,247.01

90000165

Check: 9000016563 10/02/2012 JANET HOLLEY TAX COLLECTOR Check Amount: 51,876.08

2010 TD 09658 4,373.80  
 2009 TD 2436 2,031.94  
 2009 TD 04401 1,070.70  
 2009 TD 03655 715.47  
 2009 TD 04004 779.58  
 2010 TD 11347 5,953.68  
 2010 TD 011948 6.25  
 2009 TD 02363 2,509.38

2010 TD 02233 5,446.37  
 2009 TD 01265 1,377.81  
 2009 TD 04400 1,022.79  
 2009 TD 03782 1,528.09  
 2009 TD 03048 1,431.15

*Glenn M.*  
 10-2-12