

**ERNIE LEE MAGAHA**  
CLERK OF THE CIRCUIT COURT



BRANCH OFFICES  
ARCHIVES AND RECORDS  
JUVENILE DIVISION

CENTURY

ARCHIVES AND RECORDS  
CHILD SUPPORT  
CIRCUIT CIVIL  
CIRCUIT CRIMINAL  
COUNTY CIVIL  
COUNTY CRIMINAL  
DOMESTIC RELATIONS  
FAMILY LAW  
JURY ASSEMBLY  
JUVENILE  
MENTAL HEALTH  
MIS  
OPERATIONAL SERVICES  
PROBATE  
TRAFFIC

**COUNTY OF ESCAMBIA  
OFFICE OF THE  
CLERK OF THE CIRCUIT COURT**

CLERK TO THE BOARD OF  
COUNTY COMMISSIONERS

OFFICIAL RECORDS  
COUNTY TREASURY  
AUDITOR

## IMAGING COVER PAGE

This cover page is not a part of the original documents but is necessary to avoid obscuring any information on the original documents

---

Case: 2010 TD 001745



00061724586

Dkt: TD83 Pg#:

3

---

**Original Documents Follow**

**TAX COLLECTOR'S CERTIFICATION**

**Application  
Date / Number  
Apr 25, 2012 / 120256**

This is to certify that the holder listed below of Tax Sale Certificate Number **2010 / 1745**, issued the **1st day of June, 2010**, and which encumbers the following described property located in the County of Escambia, State of Florida to wit: **Parcel ID Number: 03-0518-022**

**Certificate Holder:**  
WELLS FARGO BANK OBO TAX LIEN SECURITIZATION TRUST  
PO BOX 741307  
ATLANTA, GEORGIA 30384-1307

**Property Owner:**  
JOHNSON AWOOD  
10715 HILLGLEN AVE  
BATON ROUGE, LOUISIANA 70810

**Legal Description:** 23-1S3-013  
LOT 11 BRITNEY POINT PB 16 P 65 OR 6375 P 1507

has surrendered same in my office and made written application for tax deed in accordance with Florida Statutes. I certify that the following tax certificates, interest, ownership and encumbrance report fee, and Tax Collector's fees have been paid:

**CERTIFICATES OWNED BY APPLICANT AND FILED IN CONNECTION WITH THIS TAX DEED APPLICATION:**

Cert. Year	Certificate Number	Date of Sale	Face Amt	T/C Fee	Interest	Total
2010	1745	06/01/10	\$1,613.33	\$0.00	\$80.67	\$1,694.00

**CERTIFICATES REDEEMED BY APPLICANT OR INCLUDED (COUNTY) IN CONNECTION WITH THIS APPLICATION:**

Cert. Year	Certificate Number	Date of Sale	Face Amt	T/C Fee	Interest	Total
2011	1772.0000	06/01/11	\$1,520.94	\$6.25	\$76.05	\$1,603.24

1. Total of all Certificates in Applicant's Possession and Cost of the Certificates Redeemed by Applicant or Included (County)
2. Total of Delinquent Taxes Paid by Tax Deed Application
3. Total of Current Taxes Paid by Tax Deed Applicant (2011)
4. Ownership and Encumbrance Report Fee
5. Tax Deed Application Fee
6. Total Certified by Tax Collector to Clerk of Court
7. Clerk of Court Statutory Fee
8. Clerk of Court Certified Mail Charge
9. Clerk of Court Advertising Charge
10. Sheriff's Fee
11. \_\_\_\_\_
12. Total of Lines 6 thru 11
13. Interest Computed by Clerk of Court Per Florida Statutes.....( %)
14. One-Half of the assessed value of homestead property. If applicable pursuant to section 197.502, F.S.
15. Statutory (Opening) Bid; Total of Lines 12 thru 14
16. Redemption Fee
17. Total Amount to Redeem

\$3,297.24
\$0.00
\$1,922.00
\$150.00
\$75.00
\$5,444.24
\$5,444.24
\$6.25

\*Done this 25th day of April, 2012

TAX COLLECTOR, ESCAMBIA COUNTY, FLORIDA

By Florida Mahuron

Date of Sale: November 5, 2012

\* This certification must be surrendered to the Clerk of the Circuit Court no later than ten days after this date.

## Notice to Tax Collector of Application for Tax Deed

**TO: Tax Collector of Escambia County**

In accordance with Florida Statutes, I,

**WELLS FARGO BANK OBO TAX LIEN  
SECURITIZATION TRUST  
PO BOX 741307  
ATLANTA, Georgia, 30384-1307**

holder of the following tax sale certificate hereby surrender same to the Tax Collector and make tax deed application thereon:

<b>Certificate No.</b>	<b>Parcel ID Number</b>	<b>Date</b>	<b>Legal Description</b>
1745	03-0518-022	06/01/2010	23-1S3-013 LOT 11 BRITTNEY POINT PB 16 P 65 OR 6375 P 1507

**2011 TAX ROLL**

JOHNSON AWOOD  
10715 HILLGLEN AVE  
BATON ROUGE , Louisiana 70810

I agree to pay all delinquent taxes, redeem all outstanding certificates not in my possession, pay any omitted taxes, and pay current taxes, if due, covering the land, and pay any interest earned (a) on tax certificates not in my possession, (b) on omitted taxes or (c) on delinquent taxes. I also agree to pay all Tax Collector's fees, ownership and encumbrance reports costs, Clerk of the Court costs, charges and fees and Sheriff's costs, if applicable. Attached is the above-mentioned tax sale certificate on which this application is based and all other certificates of the same legal description which are in my possession.

wfremic10 (Shane Leach)

Applicant's Signature

04/25/2012

Date

**ERNIE LEE MAGAHA**  
CLERK OF THE CIRCUIT COURT



BRANCH OFFICES  
ARCHIVES AND RECORDS  
JUVENILE DIVISION

CENTURY

CLERK TO THE BOARD OF  
COUNTY COMMISSIONERS

OFFICIAL RECORDS  
COUNTY TREASURY  
AUDITOR

ARCHIVES AND RECORDS  
CHILD SUPPORT  
CIRCUIT CIVIL  
CIRCUIT CRIMINAL  
COUNTY CIVIL  
COUNTY CRIMINAL  
DOMESTIC RELATIONS  
FAMILY LAW  
JURY ASSEMBLY  
JUVENILE  
MENTAL HEALTH  
MIS  
OPERATIONAL SERVICES  
PROBATE  
TRAFFIC

**COUNTY OF ESCAMBIA**  
**OFFICE OF THE**  
**CLERK OF THE CIRCUIT COURT**

## IMAGING COVER PAGE

This cover page is not a part of the original documents but is necessary to avoid obscuring any information on the original documents

---

Case: 2010 TD 001745



00018745957

Dkt: TD81 Pg#:

---

4

**Original Documents Follow**

**STATE OF FLORIDA  
COUNTY OF ESCAMBIA**

**CERTIFICATE OF NOTICE OF MAILING  
NOTICE OF APPLICATION FOR TAX DEED**

**CERTIFICATE # 01745 of 2010**

I, ERNIE LEE MAGAHA, CLERK OF THE CIRCUIT COURT OF ESCAMBIA COUNTY, FLORIDA, do hereby certify that I did on October 4, 2012, mail a copy of the foregoing Notice of Application for Tax Deed, addressed to:

AWOOD JOHNSON 10715 HILLGLEN AVE BATON ROUGE, LA 70810	AWOOD JOHNSON 8263 GROVELAND AVENUE PENSACOLA, FL 32534
--	---

WITNESS my official seal this 4th day of October 2012.

**ERNIE LEE MAGAHA  
CLERK OF THE CIRCUIT COURT**

BY:   
Maryline Avila  
Deputy Clerk

SEAL



## WARNING

THERE ARE UNPAID TAXES ON PROPERTY WHICH YOU OWN OR IN WHICH YOU HAVE A LEGAL INTEREST. THE PROPERTY WILL BE SOLD AT PUBLIC AUCTION ON November 5, 2012, UNLESS THE TAXES ARE PAID. SHOULD YOU NEED FURTHER INFORMATION CONTACT THE CLERK OF THE CIRCUIT COURT IMMEDIATELY AT THE COUNTY COURTHOUSE IN PENSACOLA, FLORIDA, OR CALL 850-595-3793.

## NOTICE OF APPLICATION FOR TAX DEED

NOTICE IS HEREBY GIVEN, That **WELLS FARGO BANK OBO TAX LIENS SECURITIZATION TRUST** holder of **Tax Certificate No. 01745**, issued the 1st day of **June, A.D., 2010** has filed same in my office and has made application for a tax deed to be issued thereon. Said certificate embraces the following described property in the County of Escambia, State of Florida, to wit:

**LOT 11 BRITTNEY POINT PB 16 P 65 OR 6375 P 1507**

**SECTION 23, TOWNSHIP 1 S, RANGE 30 W**

**TAX ACCOUNT NUMBER 030518022 (12-323)**

The assessment of the said property under the said certificate issued was in the name of

**AWOOD JOHNSON**

Unless said certificate shall be redeemed according to law, the property described therein will be sold to the highest bidder at the courthouse door at 9:00 A.M. on the **first Monday** in the month of **November**, which is the **5th day of November 2012**.

Dated this 4th day of October 2012.

In accordance with the AMERICANS WITH DISABILITIES ACT, if you are a person with a disability who needs special accommodation in order to participate in this proceeding you are entitled to the provision of certain assistance. Please contact Maryline Avila not later than seven days prior to the proceeding at Escambia County Government Complex, 221 Palafox Place Ste 110, Pensacola FL 32502. Telephone: 850-595-3793.

ERNIE LEE MAGAHA  
CLERK OF THE CIRCUIT COURT  
ESCAMBIA COUNTY, FLORIDA

By:   
Maryline Avila  
Deputy Clerk



## WARNING

THERE ARE UNPAID TAXES ON PROPERTY WHICH YOU OWN OR IN WHICH YOU HAVE A LEGAL INTEREST. THE PROPERTY WILL BE SOLD AT PUBLIC AUCTION ON November 5, 2012, UNLESS THE TAXES ARE PAID. SHOULD YOU NEED FURTHER INFORMATION CONTACT THE CLERK OF THE CIRCUIT COURT IMMEDIATELY AT THE COUNTY COURTHOUSE IN PENSACOLA, FLORIDA, OR CALL 850-595-3793.

## NOTICE OF APPLICATION FOR TAX DEED

NOTICE IS HEREBY GIVEN, That **WELLS FARGO BANK OBO TAX LIENS SECURITIZATION TRUST** holder of **Tax Certificate No. 01745**, issued the 1st day of **June, A.D., 2010** has filed same in my office and has made application for a tax deed to be issued thereon. Said certificate embraces the following described property in the County of Escambia, State of Florida, to wit:

**LOT 11 BRITTNEY POINT PB 16 P 65 OR 6375 P 1507**

**SECTION 23, TOWNSHIP 1 S, RANGE 30 W**

**TAX ACCOUNT NUMBER 030518022 (12-323)**

The assessment of the said property under the said certificate issued was in the name of

**AWOOD JOHNSON**

Unless said certificate shall be redeemed according to law, the property described therein will be sold to the highest bidder at the courthouse door at 9:00 A.M. on the **first** Monday in the month of November, which is the **5th day of November 2012**.

Dated this 4th day of October 2012.

In accordance with the AMERICANS WITH DISABILITIES ACT, if you are a person with a disability who needs special accommodation in order to participate in this proceeding you are entitled to the provision of certain assistance. Please contact Maryline Avila not later than seven days prior to the proceeding at Escambia County Government Complex, 221 Palafox Place Ste 110, Pensacola FL 32502. Telephone: 850-595-3793.

ERNIE LEE MAGAHA  
CLERK OF THE CIRCUIT COURT  
ESCAMBIA COUNTY, FLORIDA

**Post Property:**

8263 GROVELAND AVE

By:



Maryline Avila  
Deputy Clerk



**ERNIE LEE MAGAHA**  
CLERK OF THE CIRCUIT COURT



BRANCH OFFICES  
ARCHIVES AND RECORDS  
JUVENILE DIVISION

CENTURY

ARCHIVES AND RECORDS  
CHILD SUPPORT  
CIRCUIT CIVIL  
CIRCUIT CRIMINAL  
COUNTY CIVIL  
COUNTY CRIMINAL  
DOMESTIC RELATIONS  
FAMILY LAW  
JURY ASSEMBLY  
JUVENILE  
MENTAL HEALTH  
MIS  
OPERATIONAL SERVICES  
PROBATE  
TRAFFIC

**COUNTY OF ESCAMBIA  
OFFICE OF THE  
CLERK OF THE CIRCUIT COURT**

CLERK TO THE BOARD OF  
COUNTY COMMISSIONERS

OFFICIAL RECORDS  
COUNTY TREASURY  
AUDITOR

## IMAGING COVER PAGE

This cover page is not a part of the original documents but is necessary to avoid obscuring any information on the original documents

---

Case: 2010 TD 001745



00017664256

Dkt: TD84 Pg#:

2

---

**Original Documents Follow**



7012 1010 0003 7013 0312

**U.S. Postal Service™  
CERTIFIED MAIL™ RECEIPT**  
(Domestic Mail Only; No Insurance Coverage Provided)

For delivery information visit our website at [www.usps.com](http://www.usps.com)®

**OFFICIAL USE**

Postage	\$ 0.45
Certified Fee	2.95
Return Receipt Fee (Endorsement Required)	2.35
Restricted Delivery Fee (Endorsement Required)	
<b>Total Postage &amp; Fees</b>	<b>\$ 5.75</b>

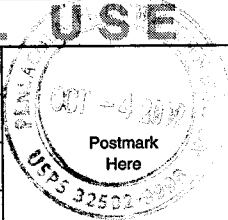

Sent To  
Street, Apt. No.,  
or PO Box No.  
City, State, ZIP+

AWOOD JOHNSON [12-323]  
10715 HILLGLEN AVE  
BATON ROUGE, LA 70810

PS Form 3800,

7012 1010 0003 7013 0312

**U.S. Postal Service™  
CERTIFIED MAIL™ RECEIPT**  
(Domestic Mail Only; No Insurance Coverage Provided)

For delivery information visit our website at [www.usps.com](http://www.usps.com)®

**OFFICIAL USE**

Postage	\$ 0.45
Certified Fee	2.95
Return Receipt Fee (Endorsement Required)	2.35
Restricted Delivery Fee (Endorsement Required)	
<b>Total Postage &amp; Fees</b>	<b>\$ 5.75</b>

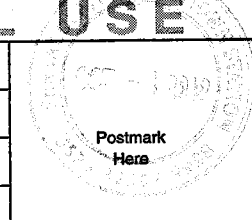

Sent To  
Street, Apt. No.  
or PO Box No.  
City, State, Zip

AWOOD JOHNSON [12-323]  
8263 GROVELAND AVENUE  
PENSACOLA, FL 32534

PS Form 3800,

**SENDER: COMPLETE THIS SECTION**

- Complete items 1, 2, and 3. Also complete item 4 if Restricted Delivery is desired.
- Print your name and address on the reverse so that we can return the card to you.
- Attach this card to the back of the mailpiece, or on the front if space permits.

1. Article Addressed to:

AWOOD JOHNSON [12-323]  
10715 HILLGLEN AVE  
BATON ROUGE, LA 70810

2. Article Number  
(Transfer from service label)

7012 1010 0003 7013 0312

PS Form 3811, February 2004

Domestic Return Receipt

PSN 7530-11-1540

**COMPLETE THIS SECTION ON DELIVERY**

A. Signature  Agent  
 Addressee

B. Received by (Printed Name) C. Date of Delivery  
AWOOD JOHNSON 10-6-07

D. Is delivery address different from item 1?  Yes  
If YES, enter delivery address below:  No

3. Service Type  
 Certified Mail  Express Mail  
 Registered  Return Receipt for Merchandise  
 Insured Mail  C.O.D.

4. Restricted Delivery? (Extra Fee)  Yes

**ERNIE LEE MAGAHA**  
CLERK OF THE CIRCUIT COURT



**BRANCH OFFICES**  
ARCHIVES AND RECORDS  
JUVENILE DIVISION

CENTURY

CLERK TO THE BOARD OF  
COUNTY COMMISSIONERS

OFFICIAL RECORDS  
COUNTY TREASURY  
AUDITOR

ARCHIVES AND RECORDS  
CHILD SUPPORT  
CIRCUIT CIVIL  
CIRCUIT CRIMINAL  
COUNTY CIVIL  
COUNTY CRIMINAL  
DOMESTIC RELATIONS  
FAMILY LAW  
JURY ASSEMBLY  
JUVENILE  
MENTAL HEALTH  
MIS  
OPERATIONAL SERVICES  
PROBATE  
TRAFFIC

**COUNTY OF ESCAMBIA**  
**OFFICE OF THE**  
**CLERK OF THE CIRCUIT COURT**

**IMAGING COVER PAGE**

This cover page is not a part of the original documents but is  
necessary to avoid obscuring any information on  
the original documents

---

Case: 2010 TD 001745



00039405563

Dkt: TD84 Pg#:

---

3

**Original Documents Follow**

ESCAMBIA COUNTY SHERIFF'S OFFICE  
ESCAMBIA COUNTY, FLORIDA

**NON-ENFORCEABLE RETURN OF SERVICE**

**Document Number:** ECSO12CIV046256NON

**Agency Number:** 13-000161

**Court:** TAX DEED

**County:** ESCAMBIA

**Case Number:** CERT #01745, 2010

**Attorney/Agent:**

HONORABLE ERNIE LEE MAGAHA  
CLERK OF COURTS  
TAX DEED DIVISION

**Plaintiff:** RE: AWOOD JOHNSON

**Defendant:**

**Type of Process:** NOTICE OF APPLICATION FOR TAX DEED

Received this Writ on 10/4/2012 at 10:19 AM and served same at 8:07 AM on 10/5/2012 in ESCAMBIA COUNTY, FLORIDA, by serving POST PROPERTY , the within named, to wit: , .

POSTED TO PROPERTY PER CLERKS INSTRUCTIONS.

DAVID MORGAN, SHERIFF  
ESCAMBIA COUNTY, FLORIDA

By: \_\_\_\_\_

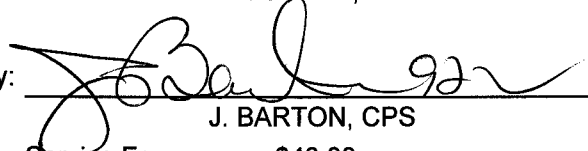

J. BARTON, CPS

Service Fee: \$40.00

Receipt No: BILL

Printed By: PMYVARRA

**WARNING**

**THERE ARE UNPAID TAXES ON PROPERTY WHICH YOU OWN OR IN WHICH YOU HAVE A LEGAL INTEREST. THE PROPERTY WILL BE SOLD AT PUBLIC AUCTION ON November 5, 2012, UNLESS THE TAXES ARE PAID. SHOULD YOU NEED FURTHER INFORMATION CONTACT THE CLERK OF THE CIRCUIT COURT IMMEDIATELY AT THE COUNTY COURTHOUSE IN PENSACOLA, FLORIDA, OR CALL 850-595-3793.**

**NOTICE OF APPLICATION FOR TAX DEED**

NOTICE IS HEREBY GIVEN, That **WELLS FARGO BANK OBO TAX LIENS SECURITIZATION TRUST** holder of **Tax Certificate No. 01745**, issued the 1st day of **June, A.D., 2010** has filed same in my office and has made application for a tax deed to be issued thereon. Said certificate embraces the following described property in the County of Escambia, State of Florida, to wit:

**LOT 11 BRITTNEY POINT PB 16 P 65 OR 6375 P 1507**

**SECTION 23, TOWNSHIP 1 S, RANGE 30 W**

**TAX ACCOUNT NUMBER 030518022 (12-323)**

The assessment of the said property under the said certificate issued was in the name of

**AWOOD JOHNSON**

Unless said certificate shall be redeemed according to law, the property described therein will be sold to the highest bidder at the courthouse door at 9:00 A.M. on the **first Monday** in the month of November, which is the **5th day of November 2012**.

Dated this 4th day of October 2012.

In accordance with the AMERICANS WITH DISABILITIES ACT, if you are a person with a disability who needs special accommodation in order to participate in this proceeding you are entitled to the provision of certain assistance. Please contact Maryline Avila not later than seven days prior to the proceeding at Escambia County Government Complex, 221 Palafox Place Ste 110, Pensacola FL 32502. Telephone: 850-595-3793.

**ERNIE LEE MAGAHA  
CLERK OF THE CIRCUIT COURT  
ESCAMBIA COUNTY, FLORIDA**

**Post Property:**

**8263 GROVELAND AVE**

By:



Maryline Avila  
Deputy Clerk



**ERNIE LEE MAGAHA**  
CLERK OF THE CIRCUIT COURT



**BRANCH OFFICES**  
ARCHIVES AND RECORDS  
JUVENILE DIVISION

CENTURY

ARCHIVES AND RECORDS  
CHILD SUPPORT  
CIRCUIT CIVIL  
CIRCUIT CRIMINAL  
COUNTY CIVIL  
COUNTY CRIMINAL  
DOMESTIC RELATIONS  
FAMILY LAW  
JURY ASSEMBLY  
JUVENILE  
MENTAL HEALTH  
MIS  
OPERATIONAL SERVICES  
PROBATE  
TRAFFIC

**COUNTY OF ESCAMBIA**  
**OFFICE OF THE**  
**CLERK OF THE CIRCUIT COURT**

CLERK TO THE BOARD OF  
COUNTY COMMISSIONERS

OFFICIAL RECORDS  
COUNTY TREASURY  
AUDITOR

## IMAGING COVER PAGE

This cover page is not a part of the original documents but is  
necessary to avoid obscuring any information on  
the original documents

---

Case: 2010 TD 001745



00008298832

Dkt: TD84 Pg#:

A large, handwritten number "2" in black ink, positioned to the right of the case information.

---

**Original Documents Follow**

**ERNIE LEE MAGAHA**  
CLERK OF THE CIRCUIT COURT & COMPTROLLER  
OFFICIAL RECORDS DIVISION  
221 Palafox Place  
P.O. Box 333  
Pensacola, FL 32591-0333

**CERTIFIED MAIL™**

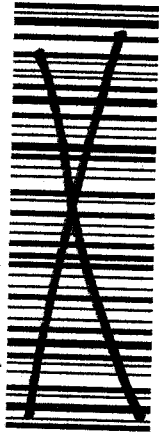

7012 1010 0003 7013 0329

neopost™  
10/04/2012  
**US POSTAGE**  
FIRST-CLASS MAIL  
**\$05.75<sup>0</sup>**  
ZIP 32502  
041111221084

AWOOD JOHNSON [12-323]  
8263 GROVELAND AVENUE  
PENSACOLA, FL 32534

First Notice 10-5  
Second Notice 10-15  
Return 10-20

NIXIE 322 DE 1 00 10/31/12  
RETURN TO SENDER  
UNCLAIMED  
UNABLE TO FORWARD  
RC: 3259103333

**UNCLAIMED**

3259103333 000

**ERNIE LEE MAGAHA**  
 CLERK OF THE COURT & COMPTROLLER  
 P.O. BOX 333  
 PENSACOLA, FL 32591-0333  
 (850) 595-4140  
 REGISTRY ACCOUNT

Bank of America  
 PENSACOLA, FL 32504  
 VOID AFTER 6 MONTHS

63-27  
 631

9000016740

PAY \*ONE HUNDRED SEVENTEEN THOUSAND NINETY FIVE AND 30/100  
 JANET HOLLEY TAX COLLECTOR

TO THE JANET HOLLEY TAX COLLECTOR  
 ORDER OF 213 PALAFOX PLACE  
 OF PENSACOLA, FL 32502

DATE AMOUNT  
 11/06/2012 117,095.30

*Ernie Lee Magaha*  
 ERNIE LEE MAGAHA, CLERK OF THE COURT



⑈9000016740⑈ ⑆063100277⑆ 898033991356⑈

**ERNIE LEE MAGAHA**  
 CLERK OF THE COURT & COMPTROLLER

9000016740

Date	Case Number	Description	Amount
11/06/2012	2008 TD 006466	PAYMENT TAX DEEDS	6.25
11/06/2012	2010 TD 003584	PAYMENT TAX DEEDS	1,191.31
11/06/2012	2010 TD 006427	PAYMENT TAX DEEDS	1,334.47
11/06/2012	2010 TD 002231	PAYMENT TAX DEEDS	13,179.46
11/06/2012	2010 TD 007686	PAYMENT TAX DEEDS	6.25
11/06/2012	2010 TD 007301	PAYMENT TAX DEEDS	7,096.83
11/06/2012	2010 TD 009699	PAYMENT TAX DEEDS	4,616.98
11/06/2012	2010 TD 001745	PAYMENT TAX DEEDS	6,022.14
11/06/2012	2010 TD 004512	PAYMENT TAX DEEDS	4,252.00
11/06/2012	2010 TD 005962	PAYMENT TAX DEEDS	6,577.75

There are additional check details for this check that total: 72,811.86

9000016740

Check: 9000016740 11/06/2012 JANET HOLLEY TAX COLLECTOR Check Amount: 117,095.30

2009 TD 08108 6.25 2010 TD 08367 26,403.67  
 2010 TD 02870 6570.93 2010 TD 05873 4,649.28  
 2010 TD 00016 11,468.14-  
 2010 TD 02363 6.25  
 2010 TD 03923 3,904.07  
 2010 TD 02761 2,808.92  
 2010 TD 00609 6.25  
 2010 TD 01206 25.00  
 2010 TD 02366 9824.68  
 2010 TD 05988 7,138.41

*CL 11/6/12*

**ERNIE LEE MAGAHA**  
 CLERK OF THE COURT & COMPTROLLER  
 P.O. BOX 333  
 PENSACOLA, FL 32591-0333  
 (850) 595-4140  
 REGISTRY ACCOUNT

Bank of America  
 PENSACOLA, FLORIDA  
 VOID AFTER 8 MONTHS

63-27  
 631

9000016765

PAY \*TWENTY NINE THOUSAND THREE HUNDRED SIXTY SEVEN AND 52/100

WELLS FARGO BANK OBO TAX LIENS  
 SECURITIZATION TRUST

TO THE ORDER OF  
 WELLS FARGO BANK OBO TAX LIENS SECURITIZATI  
 P O BOX 741307  
 ATLANTA, GA 30384

DATE AMOUNT  
 11/06/2012 29,367.52

*Ernie Lee Magaha*

ERNIE LEE MAGAHA, CLERK OF THE COURT



⑈9000016765⑈ ⑆063100277⑆ 898033991356⑈

**ERNIE LEE MAGAHA**  
 CLERK OF THE COURT & COMPTROLLER

9000016765

Date	Case Number	Description	Amount
11/06/2012	2010 TD 000609	PAYMENT TAX DEEDS	9,682.21
11/06/2012	2010 TD 009699	PAYMENT TAX DEEDS	437.09
11/06/2012	2010 TD 002870	PAYMENT TAX DEEDS	443.11
11/06/2012	2010 TD 000016	PAYMENT TAX DEEDS	443.11
11/06/2012	2010 TD 005873	PAYMENT TAX DEEDS	443.11
11/06/2012	2010 TD 001745	PAYMENT TAX DEEDS	443.11
11/06/2012	2010 TD 005962	PAYMENT TAX DEEDS	443.11
11/06/2012	2010 TD 006427	PAYMENT TAX DEEDS	443.11
11/06/2012	2010 TD 002306	PAYMENT TAX DEEDS	437.09
11/06/2012	2010 TD 008367	PAYMENT TAX DEEDS	443.11

There are additional check details for this check that total:

15,709.39 **9000016765**

Check: 9000016765 11/06/2012 WELLS FARGO BANK OBO TAX LIENS SECURITIZATION TRUST Check Amount: 29,367.52

2010 TD 07686 4,421.09  
 2010 TD 05988 437.09  
 2010 TD 02303 9,816.90  
 2010 TD 07301 503.88  
 2010 TD 02231 530.40



**ERNIE LEE MAGAHA**  
CLERK OF THE COURT & COMPTROLLER  
P.O. BOX 333  
PENSACOLA, FL 32591-0333  
(850) 595-4140  
REGISTRY ACCOUNT

Bank of America  
PENSACOLA, FL  
VOID AFTER 6 MONTHS

9000016726

63-27  
631

PAY

\*EIGHTY AND 00/100

AWOOD JOHNSON

TO THE ORDER OF  
AWOOD JOHNSON  
10715 HILLGLEN AVE  
BATON ROUGE, LA 70810

DATE AMOUNT  
11/06/2012 80.00

*Ernie Lee Magaha*

ERNIE LEE MAGAHA, CLERK OF THE COURT



⑈9000016726⑈ ⑆063100277⑆ 898033991356⑈

**ERNIE LEE MAGAHA**  
CLERK OF THE COURT & COMPTROLLER

9000016726

<u>Date</u>	<u>Case Number</u>	<u>Description</u>	<u>Amount</u>
11/06/2012	2010 TD 001745	PAYMENT TAX DEEDS	80.00

Check: 9000016726 11/06/2012 AWOOD JOHNSON

Check Amount: 80.00

9000016726



**ERNIE LEE MAGAHA**  
**CLERK OF THE CIRCUIT COURT**  
**ESCAMBIA COUNTY, FLORIDA**

**Tax Deed - Redemption Calculator**  
 Account: 030518022 Certificate Number: 001745 of 2010

Redemption  Yes  
 Application Date   
 Interest Rate

	Final Redemption Payment ESTIMATED	Redemption Overpayment ACTUAL
	Auction Date <input type="text" value="11/05/2012"/>	Redemption Date <input type="text" value="11/02/2012"/> <input type="checkbox"/>
Months	<input type="text" value="7"/>	<input type="text" value="7"/>
Tax Collector	<input type="text" value="\$5,444.24"/>	<input type="text" value="\$5,444.24"/>
Tax Collector Interest	<input type="text" value="\$571.65"/>	<input type="text" value="\$571.65"/>
Tax Collector Fee	<input type="text" value="\$6.25"/>	<input type="text" value="\$6.25"/>
<b>Total Tax Collector</b>	<b>\$6,022.14</b>	<b>\$6,022.14</b>
Clerk Fee	<input type="text" value="\$60.00"/>	<input type="text" value="\$60.00"/>
Sheriff Fee	<input type="text" value="\$120.00"/>	<input type="text" value="\$120.00"/>
Legal Advertisement	<input type="text" value="\$221.00"/>	<input type="text" value="\$221.00"/>
App. Fee Interest	<input type="text" value="\$42.11"/>	<input type="text" value="\$42.11"/>
<b>Total Clerk</b>	<b>\$443.11</b>	<b>\$443.11</b>
Postage	<input type="text" value="\$12.00"/>	<input type="text" value="\$12.00"/>
Researcher Copies	<input type="text" value="\$5.00"/>	<input type="text" value="\$5.00"/>
<b>Total Redemption Amount</b>	<b>\$6,482.25</b>	<b>\$6,482.25</b>
	Repayment Overpayment Refund Amount	<input type="text" value="\$0.00"/> +80.00

Notes  ACTUAL SHERIFF \$40.00 COM FEE \$18.50  
 05/22/2012 AWOOD JOHNSON CALLED FOR REDEMPTION QUOTE...MVA  
 9/18/2012 AWOOD JOHNSON CALLED FOR REDEMPTION QUOTE...MVA

Ernie Lee Magaha,  
Clerk of the Circuit Court of Escambia County Florida

Receipt Type Case Outstanding Amount 0.00  
Receipt Number 1468343 Receipt Date 11/02/2012

Case Number 2010 TD 001745

Description WELLS FARGO BANK OBO TAX LIENS VS

Action TAX DEED REDEMPTION

Judge

Received From AWOOD JOHNSON

On Behalf Of WELLS FARGO BANK OBO TAX LIENS

Total Received	6,482.25
Net Received	6,482.25
Change	0.00

Receipt Payments	Amount	Reference Description
Cash	6,482.25	CASH

Receipt Applications	Amount
Holding	6,465.25
Service Charge	17.00

Deputy Clerk: mavila Transaction Date 11/02/2012 12:03:59

Comments

**ERNIE LEE MAGAHA**  
 CLERK OF THE CIRCUIT COURT  
 ARCHIVES AND RECORDS  
 CHILDSUPPORT  
 CIRCUIT CIVIL  
 CIRCUIT CRIMINAL  
 COUNTY CIVIL  
 COUNTY CRIMINAL  
 DOMESTIC RELATIONS  
 FAMILY LAW  
 JURY ASSEMBLY  
 JUVENILE  
 MENTAL HEALTH  
 MIS  
 OPERATIONAL SERVICES  
 PROBATE  
 TRAFFIC

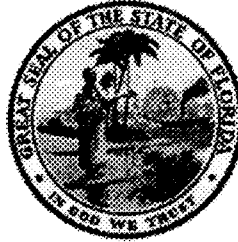

**BRANCH OFFICES**  
**ARCHIVES AND RECORDS**  
**JUVENILE DIVISION**  
**CENTURY**

CLERK TO THE BOARD OF  
 COUNTY COMMISSIONERS  
 OFFICIAL RECORDS  
 COUNTY TREASURY  
 AUDITOR

**COUNTY OF ESCAMBIA**  
**OFFICE OF THE**  
**CLERK OF THE CIRCUIT COURT**

**ERNIE LEE MAGAHA, CLERK OF THE CIRCUIT COURT**  
**Tax Certificate Redeemed From Sale**

**Account: 030518022 Certificate Number: 001745 of 2010**

**Payor: AWOOD JOHNSON 10715 HILLGLEN AVE BATON ROUGE, LA 70810 Date**  
**11/02/2012**

Clerk's Check #	1	Clerk's Total	\$443.11
Tax Collector Check #	1	Tax Collector's Total	\$6,022.14
		Postage	\$12.00
		Researcher Copies	\$5.00
		Total Received	\$6,482.25

**ERNIE LEE MAGAHA**  
 Clerk of the Circuit Court

Received By: \_\_\_\_\_  
 Deputy Clerk

Escambia County Government Complex • 221 Palafox Place Ste 110 • PENSACOLA, FLORIDA 32502  
 (850) 595-3793 • FAX (850) 595-4827 • <http://www.clerk.co.escambia.fl.us>

**ERNIE LEE MAGAHA**  
 CLERK OF THE CIRCUIT COURT  
 ARCHIVES AND RECORDS  
 CHILDSUPPORT  
 CIRCUIT CIVIL  
 CIRCUIT CRIMINAL  
 COUNTY CIVIL  
 COUNTY CRIMINAL  
 DOMESTIC RELATIONS  
 FAMILY LAW  
 JURY ASSEMBLY  
 JUVENILE  
 MENTAL HEALTH  
 MIS  
 OPERATIONAL SERVICES  
 PROBATE  
 TRAFFIC

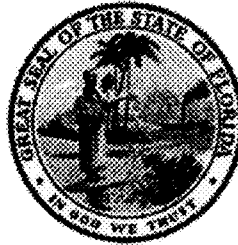

**COUNTY OF ESCAMBIA  
 OFFICE OF THE  
 CLERK OF THE CIRCUIT COURT**

**BRANCH OFFICES  
 ARCHIVES AND RECORDS  
 JUVENILE DIVISION  
 CENTURY**

CLERK TO THE BOARD OF  
 COUNTY COMMISSIONERS  
 OFFICIAL RECORDS  
 COUNTY TREASURY  
 AUDITOR

**Case # 2010 TD 001745**

**Redeemed Date 11/02/2012**

**Name AWOOD JOHNSON 10715 HILLGLEN AVE BATON ROUGE, LA 70810**

Clerk's Total = TAXDEED	\$443.11
Due Tax Collector = TAXDEED	\$6,022.14
Postage = TD2	\$12.00
ResearcherCopies = TD6	\$5.00

**Apply Docket Codes**

• For Office Use Only

Date	Docket	Desc	Amount Owed	Amount Due	Payee Name
06/01/2010	TD1	TAX DEED APPLICATION Receipt: 1415563 Date: 05/24/2012	60.00	0.00	
06/01/2010	TAXDEED	TAX DEED CERTIFICATES Receipt: 1415563 Date: 05/24/2012	341.00	0.00	
06/04/2012	TD83	TAX COLLECTOR CERTIFICATION	0.00	0.00	
08/23/2012	TD82	O & E REPORT	0.00	0.00	
10/08/2012	TD81	CERTIFICATE OF MAILING	0.00	0.00	
10/12/2012	TD84	CORRESPONDENCE(certified mail receipts, green card)mva	0.00	0.00	
10/15/2012	TD84	CORRESPONDENCE(sheriff notice, property posted)mva	0.00	0.00	
10/26/2012	TAXDEEDPAY	PAYMENT TAX DEEDS	221.00	0.00	ESCAMBIA SUN PRESS - 605 S. OLD CORRY FIELD RD
11/02/2012	TAXDEED	TAXDEED Clerk's Total	443.11	443.11	
11/02/2012	TAXDEED	TAXDEED Due Tax Collector	6,022.14	6,022.14	
11/02/2012	TD2	POSTAGE TAX DEEDS	12.00	12.00	
11/02/2012	TD6	TITLE RESEARCHER COPY CHARGES	5.00	5.00	

**FINANCIAL SUMMARY**

Rcd	Docket Application	Owed	Paid	Dismissed	Due
1	Funds Disbursed	\$221.00	\$221.00	\$0.00	\$0.00
2	Service Charge	\$77.00	\$60.00	\$0.00	\$17.00
3	Holding	\$6,806.25	\$341.00	\$0.00	\$6,465.25
	<b>TOTAL</b>	<b>\$7,104.25</b>	<b>\$622.00</b>	<b>\$0.00</b>	<b>\$6,482.25</b>

# THE ESCAMBIA SUN-PRESS, LLC



PUBLISHED WEEKLY SINCE 1948

(Warrington) Pensacola, Escambia County, Florida

## NOTICE OF APPLICATION FOR TAX DEED

NOTICE IS HEREBY GIVEN, That WELLS FARGO BANK OBO TAX LIENS SECURITIZATION TRUST holder of Tax Certificate No. 01745, issued the 1st day of June, A.D., 2010 has filed same in my office and has made application for a tax deed to be issued thereon. Said certificate embraces the following described property in the County of Escambia, State of Florida, to wit:

LOT 11 BRITNEY POINT PB 16 P 65 OR 6375 P 1507

SECTION 23, TOWNSHIP 1 S, RANGE 30 W

TAX ACCOUNT NUMBER 030518022 (12-323)

The assessment of the said property under the said certificate issued was in the name of AWOOD JOHNSON

Unless said certificate shall be redeemed according to law, the property described therein will be sold to the highest bidder at the courthouse door at 9:00 A.M. on the first Monday in the month of November, which is the 5th day of November 2012.

Dated this 4th day of October 2012.

In accordance with the AMERICANS WITH DISABILITIES ACT, if you are a person with a disability who needs special accommodation in order to participate in this proceeding you are entitled to the provision of certain assistance. Please contact Maryline Avila not later than seven days prior to the proceeding at Escambia County Government Complex, 221 Palafox Place Ste 110, Pensacola FL 32502. Telephone: 850-595-3793.

ERNIE LEE MAGAHA  
CLERK OF THE CIRCUIT COURT  
ESCAMBIA COUNTY, FLORIDA  
(SEAL)

By: Maryline Avila  
Deputy Clerk

oaw-4w-10-4-11-18-25-2012

## STATE OF FLORIDA

County of Escambia

Before the undersigned authority personally appeared  
Michael J. Driver

who is personally known to me and who on oath says that he is Publisher of The Escambia Sun Press, a weekly newspaper published at (Warrington) Pensacola in Escambia County, Florida; that the attached copy of advertisement, being a NOTICE in the matter of TAX DEED SALE  
SALE: 11/05/2012 - TAX CERT #: 01745

\_\_\_\_\_ in the \_\_\_\_\_ CIRCUIT \_\_\_\_\_ Court  
was published in said newspaper in the issues of \_\_\_\_\_  
OCTOBER 4, 11, 18, 25, 2012

Affiant further says that the said Escambia Sun-Press is a newspaper published at (Warrington) Pensacola, in said Escambia County, Florida, and that the said newspaper has heretofore been continuously published in said Escambia County, Florida each week and has been entered as second class mail matter at the post office in Pensacola, in said Escambia County, Florida, for a period of one year next preceding the first publication of the attached copy of advertisement; and affiant further says that he has neither paid nor promised any person, firm or corporation any discount, rebate, commission or refund for the purpose of securing this advertisement for publication in the said newspaper.

Michael J. Driver

PUBLISHER

Sworn to and subscribed before me this 25<sup>TH</sup>  
day of OCTOBER \_\_\_\_\_ A.D., 2012

Denise G. Turner

DENISE G. TURNER

NOTARY PUBLIC

Denise G. Turner  
Notary Public  
State of Florida

My Commission Expires 08/24/2016  
My Commission No.EE 207775

User: ec0724 P

Client:

Search: Bankruptcy Party Search Name JOHNSON, AWOOD Louisiana Page: 1

No records found

<b>PACER Service Center</b>	Receipt 10/29/2012 13:48:50 37975867
User ec0724 P	
Client	
Description Bankruptcy Party Search	
Name JOHNSON, AWOOD Louisiana Page: 1	
Pages 1 (50 10)	

User: ec0724 P  
Client:  
Search: Bankruptcy Party Search Name JOHNSON, AWOOD Florida Northern Page: 1

No records found

<b>PACER Service Center</b>	Receipt 10/29/2012 13:49:13 37976036
User ec0724 P	
Client	
Description Bankruptcy Party Search	
Name JOHNSON, AWOOD Florida Northern Page: 1	
Pages 1 (\$0.10)	





ERNIE LEE MAGAHA  
 Clerk of the Circuit Court  
 Escambia County, FL  
 P.O. Box 333  
 Pensacola, FL 32591  
 850-595-3930

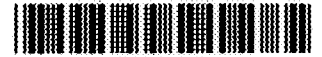

**Print Date:**  
 5/24/2012 11:09:23  
 AM

Transaction #: **938063**  
 Receipt #: **201231542**  
 Cashier Date: **5/24/2012 11:09:22 AM (MAVILA)**

Customer Information	Transaction Information	Payment Summary
(TXD) TAX DEED DIVISION CLERK OF THE CIRCUIT COURT 221 PALAFOX PLACE Pensacola, FL 32502	Date Received: 05/24/2012 Source Code: Over the Counter Q Code: Return Code: Government Trans Type: Recording Agent Ref Num:	Total Fees \$401.00 Total Payments \$401.00

1 Payments		
 CLERK		\$401.00

0 Recorded Items		
------------------	--	--

0 Search Items		
----------------	--	--

1 Miscellaneous Items		
 (MISCFEE) MISCELLANEOUS FEES TAX CERT#01745 OF 2010		
TAXCR	341	\$341.00
TAXCT	1	\$60.00

Ernie Lee Magaha,  
Clerk of the Circuit Court of Escambia County Florida

Receipt Type Case Outstanding Amount 0.00  
Receipt Number 1415563 Receipt Date 05/24/2012

Case Number 2010 TD 001745

Description WELLS FARGO BANK OBO TAX LIENS VS

Action TAX DEED APPLICATION

Judge

Received From WELLS FARGO BANK OBO TAX LIENS

On Behalf Of WELLS FARGO BANK OBO TAX LIENS

Total Received	401.00
Net Received	401.00
Change	0.00

Receipt Payments	Amount	Reference Description
Cash	401.00	ONCORE TRANS#938063

Receipt Applications	Amount
Holding	341.00
Service Charge	60.00

Deputy Clerk: mavila Transaction Date 05/24/2012 11:10:52

Comments



# Chris Jones

## Escambia County Property Appraiser

Real Estate Search | Tangible Property Search | Amendment 1 Calculations

[Back](#)



**Navigate Mode**



**Account**

Reference



[Printer Friendly Version](#)

<b>General Information</b>		<b>2011 Certified Roll Assessment</b>	
<b>Reference:</b>	231S301300000110	<b>Improvements:</b>	\$93,693
<b>Account:</b>	030518022	<b>Land:</b>	\$21,375
<b>Owners:</b>	JOHNSON AWOOD	<b>Total:</b>	\$115,068
<b>Mail:</b>	10715 HILLGLEN AVE BATON ROUGE, LA 70810	<b>Save Our Homes:</b>	\$0
<b>Situs:</b>	8263 GROVELAND AVE 32534	<a href="#">Disclaimer</a>	
<b>Use Code:</b>	SINGLE FAMILY RESID <input checked="" type="checkbox"/>	<b>Amendment 1 Calculations</b>	
<b>Taxing Authority:</b>	COUNTY MSTU		
<b>Tax Inquiry:</b>	<a href="#">Open Tax Inquiry Window</a>		
Tax Inquiry link courtesy of Janet Holley, Escambia County Tax Collector			
<b>Sales Data</b>		<b>2011 Certified Roll Exemptions</b>	
		None	
<b>Sale Date</b>	<b>Book Page</b>	<b>Value</b>	<b>Type</b>
			<b>Official Records (New Window)</b>
09/09/2008	6375 1507	\$100	QC
12/2005	5803 1737	\$112,700	WD
08/2004	5495 151	\$140,000	WD
03/2004	5357 1613	\$25,000	WD
			<a href="#">View Instr</a>
			<a href="#">View Instr</a>
			<a href="#">View Instr</a>
			<a href="#">View Instr</a>
Official Records Inquiry courtesy of Ernie Lee Magaha, Escambia County Clerk of the Court		<b>Legal Description</b>	
		LOT 11 BRITNEY POINT PB 16 P 65 OR 6375 P 1507	
		<b>Extra Features</b>	
		None	

**Parcel Information** [Restore Map](#) [Get Map Image](#) [Launch Interactive Map](#)

**Section Map Id:**  
23-15-30-1

**Approx. Acreage:**  
0.2400

**Zoned:**   
R-2

**Buildings**

**Building 1 - Address: 8263 GROVELAND AVE, Year Built: 2004, Effective Year: 2004**

**Structural Elements**

**FOUNDATION-SLAB ON GRADE**  
**EXTERIOR WALL-BRICK-FACE**  
**NO. PLUMBING FIXTURES-8.00**  
**DWELLING UNITS-1.00**  
**ROOF FRAMING-HIP**  
**ROOF COVER-COMPOSITION SHG**  
**INTERIOR WALL-DRYWALL-PLASTER**  
**FLOOR COVER-CARPET**  
**NO. STORIES-1.00**  
**FLOOR COVER-TILE/STAIN**  
**CONC/BRICK**  
**DECOR/MILLWORK-AVERAGE**  
**HEAT/AIR-CENTRAL H/AC**  
**STRUCTURAL FRAME-WOOD FRAME**

**Areas - 2497 Total SF**

**BASE AREA - 1710**

**GARAGE FIN - 538**

**OPEN PORCH FIN - 105**

**PATIO - 144**

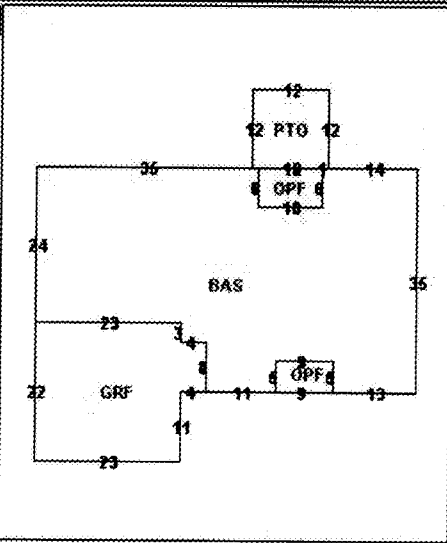

**Images**

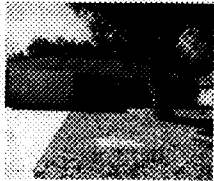

2/14/11

The primary use of the assessment data is for the preparation of the current year tax roll. No responsibility or liability is assumed for inaccuracies or errors.