

PAM CHILDERS
CLERK OF THE CIRCUIT COURT



BRANCH OFFICES
ARCHIVES AND RECORDS
JUVENILE DIVISION

ARCHIVES AND RECORDS
CHILD SUPPORT
CIRCUIT CIVIL
CIRCUIT CRIMINAL
COUNTY CIVIL
COUNTY CRIMINAL
DOMESTIC RELATIONS
FAMILY LAW
JURY ASSEMBLY
JUVENILE
MENTAL HEALTH
MIS
OPERATIONAL SERVICES
PROBATE
TRAFFIC

**COUNTY OF ESCAMBIA
OFFICE OF THE
CLERK OF THE CIRCUIT COURT**

CENTURY

CLERK TO THE BOARD OF
COUNTY COMMISSIONERS

OFFICIAL RECORDS
COUNTY TREASURY
AUDITOR

IMAGING COVER PAGE

This cover page is not a part of the original documents but is necessary to avoid obscuring any information on the original documents

Case: 2009 TD 004118



00066334407

Dkt: TD83 Pg#:

3

Original Documents Follow

Notice to Tax Collector of Application for Tax Deed

TO: Tax Collector of Escambia County

In accordance with Florida Statutes, I,

**TAX LIEN FUND I, LP
P.O. BOX 1074
ELMHURST, Illinois, 60126**

holder of the following tax sale certificate hereby surrender same to the Tax Collector and make tax deed application thereon:

Certificate No.	Parcel ID Number	Date	Legal Description
4118	06-2953-000	06/01/2009	18-2S3-060 LTS 1 2 BLK 53 DB 555 P 772 ENGLEWOOD HEIGHTS PLAT DB 59 P 107

2012 TAX ROLL

JOHNSON IOLA EST OF
2920 N F ST
PENSACOLA , Florida 32501

I agree to pay all delinquent taxes, redeem all outstanding certificates not in my possession, pay any omitted taxes, and pay current taxes, if due, covering the land, and pay any interest earned (a) on tax certificates not in my possession, (b) on omitted taxes or (c) on delinquent taxes. I also agree to pay all Tax Collector's fees, ownership and encumbrance reports costs, Clerk of the Court costs, charges and fees and Sheriff's costs, if applicable. Attached is the above-mentioned tax sale certificate on which this application is based and all other certificates of the same legal description which are in my possession.

ttaxl2 (Tax Lien Fund I, LP Tax Lien Fund I, LP)

Applicant's Signature

12/07/2012

Date

PAM CHILDERS
CLERK OF THE CIRCUIT COURT



BRANCH OFFICES
ARCHIVES AND RECORDS
JUVENILE DIVISION

CENTURY

ARCHIVES AND RECORDS
CHILD SUPPORT
CIRCUIT CIVIL
CIRCUIT CRIMINAL
COUNTY CIVIL
COUNTY CRIMINAL
DOMESTIC RELATIONS
FAMILY LAW
JURY ASSEMBLY
JUVENILE
MENTAL HEALTH
MIS
OPERATIONAL SERVICES
PROBATE
TRAFFIC

**COUNTY OF ESCAMBIA
OFFICE OF THE
CLERK OF THE CIRCUIT COURT**

CLERK TO THE BOARD OF
COUNTY COMMISSIONERS

OFFICIAL RECORDS
COUNTY TREASURY
AUDITOR

IMAGING COVER PAGE

This cover page is not a part of the original documents but is necessary to avoid obscuring any information on the original documents

Case: 2009 TD 004118



00099236892

Dkt: TD82 Pg#:

6

Original Documents Follow

Southern Guaranty Title Company

4400 Bayou Boulevard, Suite 13B

Pensacola, Florida 32503

Telephone: 850-478-8121

Facsimile: 850-476-1437

OWNERSHIP AND ENCUMBRANCE REPORT

File No.: 10175

February 11, 2013

Escambia County Tax Collector
P.O. Box 1312
Pensacola, Florida 32569

Pursuant to your request, the Company has caused a search to be made of the Public Records of Escambia County, Florida, solely as revealed by records maintained from 02-11-1993, through 02-11-2013, and said search reveals the following:

1. THE GRANTEE(S) OF THE LAST DEED(S) OF RECORD IS:

Estate of Iola Johnson

2. The land covered by this Report is:

LEGAL DESCRIPTION IS ATTACHED HERETO AND MADE A PART HEREOF

3. The following unsatisfied mortgages, liens and judgments affecting the land covered by this Report appear of record:

SEE CONTINUATION PAGE ATTACHED HERETO AND MADE A PART HEREOF

4. Taxes:

SEE CONTINUATION PAGE ATTACHED HERETO AND MADE A PART HEREOF

The foregoing report is prepared and furnished for information only, is not intended to constitute or imply any opinion, warranty, guaranty, insurance, or similar assurance as to the status of title, and no determination has been made of the authenticity of any instrument described or referred to herein. The name search for the purposes of determining applicable judgments and liens is limited to the apparent record owner(s) shown herein, No attempt has been made to determine whether the land is subject to liens or assessments which are not shown as existing liens by the public records. The Company's liability hereunder shall not exceed the cost of this Report, or \$1,000.00 whichever is less.

THIS REPORT SHALL NOT BE USED FOR THE ISSUANCE OF TITLE INSURANCE.

Southern Guaranty Title Company

By: 

February 11, 2013

**OWNERSHIP AND ENCUMBRANCE REPORT
LEGAL DESCRIPTION**

File No.: 10175

February 11, 2013

**Lots 1 and 2, Block 53, Deed Book 555, page 772, Englewood Heights, Plat Deed Book 59,
page 107, O.R. Book**

**OWNERSHIP AND ENCUMBRANCE REPORT
CONTINUATION PAGE**

File No.: 10175

February 11, 2013

UNSATISFIED MORTGAGES, LIENS AND JUDGMENTS AFFECTING THE LAND COVERED BY THIS REPORT THAT APPEAR OF RECORD:

1. Taxes for the year 2008-2011 delinquent. The assessed value is \$58,571.00. Tax ID 03-2953-000.

PLEASE NOTE THE FOLLOWING:

- A. Taxes and assessments due now or in subsequent years.
- B. Subject to Easements, Restrictions and Covenants of record.
- C. Oil, gas, mineral or any other subsurface rights of any kind or nature.
- D. Encroachments, overlaps, boundary line disputes, and any other matters which would be disclosed by an accurate survey and inspection of the premises.

SOUTHERN GUARANTY TITLE COMPANY

4400 BAYOU BLVD., SUITE 13-B, CORDOVA SQUARE

PENSACOLA, FLORIDA 32503

TEL. (850) 478-8121 FAX (850) 476-1437

Email: rcsqt@aol.com

Janet Holley
Escambia County Tax Collector
P.O. Box 1312
Pensacola, FL 32596

CERTIFICATION: TITLE SEARCH FOR TDA

TAX DEED SALE DATE: 9-3-2013

TAX ACCOUNT NO.: 06-2953-000

CERTIFICATE NO.: 2009-4118

In compliance with Section 197.256, Florida Statutes, the following is a list of names and addresses of those persons, firms and/or agencies having legal interest in or claim against the above described property. The above referenced tax sale certificate is being submitted as proper notification of tax deed sale.

YES NO

 X Notify City of Pensacola, P.O. Box 12910, 32521

 X Notify Escambia County, 190 Governmental Center, 32502

 X Homestead for tax year.

Estate of Iola Johnson
2920 North F St.
Pensacola, FL 32501

Certified and delivered to Escambia County Tax Collector,
this 11th day of February, 2013.

SOUTHERN GUARANTY TITLE COMPANY

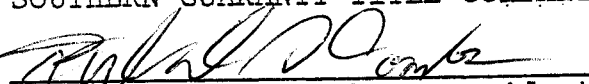
by: Richard S. Combs, President

NOTE: The above listed addresses are based upon current information available, but said addresses are not guaranteed to be true or correct.

175

State of Florida
Escambia County

DEED 555 OF 772
WARRANTY DEED

LANGLEY BELL
CLERK OF CIRCUIT COURT
PENSACOLA, ESCAMBIA CO., FLA.

3507 H. Hays

Know All Men by These Presents: that Ms. Nana S. Heiberg and B. R. Heiberg,
wife and husband, of Pensacola, Florida.

for and in consideration of ONE & NO/100 (\$1.00) DOLLARS
and other good and valuable considerations,
the receipt whereof is hereby acknowledged, do bargain, sell, convey and grant unto
Thomas G. Johnson and Lola Johnson, husband and wife, of Pensacola, Florida,

their heirs, executors, administrators and assigns, forever, the following described real property,
situate, lying and being in the Escambia County of Florida State of Florida.
to-wit: Lots # 1 & 2, in Block # 53, Englewood Heights, A Subdivision of Section 18,
Township 2 South, Range 30 West, Escambia County, Florida, according to the map
made by L. E. Thornton, Civil Engineer, in October 1909, and recorded in Deed Book
59, at Page # 107, of the records of Escambia County, Florida.

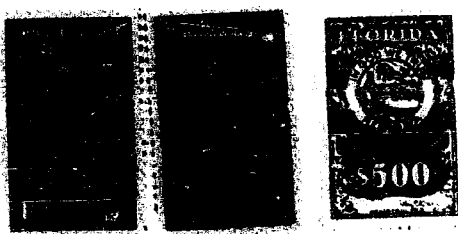

FILED & RECORDED IN
THE RECORDS AND CLERK'S OFFICE OF
ESCAMBIA COUNTY, FLORIDA ON
JUN 30 9 49 AM '61
J. A. TOMERS, CLERK
CIRCUIT COURT

To have and to hold, unto the said grantee their heirs and assigns, forever.
Together with all and singular the tenements, hereditaments and appurtenances thereto belonging or in any-
wise appertaining, free from all exemptions and right of homestead.

And we covenant that we are well seized of an indefeasible
estate in fee simple in the said property, and we a good right to convey the same; that it is free of lien or encum-
brance, and that our heirs, executors and administrators, the said grantee their heirs,
executors, administrators and assigns, in the quiet and peaceable possession and enjoyment thereof, against all
persons lawfully claiming the same, shall and will forever warrant and defend.

IN WITNESS WHEREOF, we have hereunto set our hand and seal this 30th
day of June A. D. 19 61.

Signed, sealed and delivered in the presence of
Agnes H. Heiberg (SEAL)
Betty Lou Fee (SEAL)

_____ (SEAL)

State of Florida
Escambia County

Before the subscriber personally appeared B. R. Heiberg
and Nana S. Heiberg

his wife, known to me, and known to me to be the individual B described by said name B in and who executed
the foregoing instrument and acknowledged that they executed the same for the uses and purposes therein set
forth.

Witness my hand and official seal this 30th day of June 19 61.



Betty Lou Fee
My Commission expires Nov. 22, 1964
My commission expires _____

**STATE OF FLORIDA
COUNTY OF ESCAMBIA**

**CERTIFICATE OF NOTICE OF MAILING
NOTICE OF APPLICATION FOR TAX DEED**

CERTIFICATE # 04118 of 2009

I, PAM CHILDERS, CLERK OF THE CIRCUIT COURT OF ESCAMBIA COUNTY, FLORIDA, do hereby certify that I did on August 1, 2013, mail a copy of the foregoing Notice of Application for Tax Deed, addressed to:

EST OF IOLA JOHNSON 2920 N F ST PENSACOLA, FL 325

WITNESS my official seal this 1st day of August 2013.

**PAM CHILDERS
CLERK OF THE CIRCUIT COURT**

SEAL

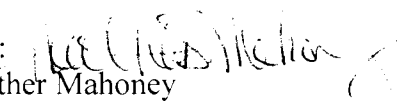
BY: 
Heather Mahoney
Deputy Clerk

WARNING

THERE ARE UNPAID TAXES ON PROPERTY WHICH YOU OWN OR IN WHICH YOU HAVE A LEGAL INTEREST. THE PROPERTY WILL BE SOLD AT PUBLIC AUCTION ON September 3, 2013, UNLESS THE TAXES ARE PAID. SHOULD YOU NEED FURTHER INFORMATION CONTACT THE CLERK OF THE CIRCUIT COURT IMMEDIATELY AT THE COUNTY COURTHOUSE IN PENSACOLA, FLORIDA, OR CALL 850-595-3793.

NOTICE OF APPLICATION FOR TAX DEED

NOTICE IS HEREBY GIVEN, That **TAX LIEN FUND I, LP** holder of **Tax Certificate No. 04118**, issued the **1st** day of **June, A.D., 2009** has filed same in my office and has made application for a tax deed to be issued thereon. Said certificate embraces the following described property in the County of Escambia, State of Florida, to wit:

LTS 1 2 BLK 53 DB 555 P 772 ENGLEWOOD HEIGHTS PLAT DB 59 P 107

SECTION 18, TOWNSHIP 2 S, RANGE 30 W

TAX ACCOUNT NUMBER 062953000 (13-599)

The assessment of the said property under the said certificate issued was in the name of

EST OF IOLA JOHNSON

Unless said certificate shall be redeemed according to law, the property described therein will be sold to the highest bidder at the courthouse door at 9:00 A.M. on the **first** Tuesday in the month of September, which is the **3rd day of September 2013**.

Dated this 1st day of August 2013.

In accordance with the AMERICANS WITH DISABILITIES ACT, if you are a person with a disability who needs special accommodation in order to participate in this proceeding you are entitled to the provision of certain assistance. Please contact Maryline Avila not later than seven days prior to the proceeding at Escambia County Government Complex, 221 Palafox Place Ste 110, Pensacola FL 32502. Telephone: 850-595-3793.

PAM CHILDERS
CLERK OF THE CIRCUIT COURT
ESCAMBIA COUNTY, FLORIDA

By: 

Heather Mahoney
Deputy Clerk

WARNING

THERE ARE UNPAID TAXES ON PROPERTY WHICH YOU OWN OR IN WHICH YOU HAVE A LEGAL INTEREST. THE PROPERTY WILL BE SOLD AT PUBLIC AUCTION ON September 3, 2013, UNLESS THE TAXES ARE PAID. SHOULD YOU NEED FURTHER INFORMATION CONTACT THE CLERK OF THE CIRCUIT COURT IMMEDIATELY AT THE COUNTY COURTHOUSE IN PENSACOLA, FLORIDA, OR CALL 850-595-3793.

NOTICE OF APPLICATION FOR TAX DEED

NOTICE IS HEREBY GIVEN, That **TAX LIEN FUND I, LP** holder of **Tax Certificate No. 04118**, issued the **1st** day of **June, A.D., 2009** has filed same in my office and has made application for a tax deed to be issued thereon. Said certificate embraces the following described property in the County of Escambia, State of Florida, to wit:

LTS 1 2 BLK 53 DB 555 P 772 ENGLEWOOD HEIGHTS PLAT DB 59 P 107

SECTION 18, TOWNSHIP 2 S, RANGE 30 W

TAX ACCOUNT NUMBER 062953000 (13-599)

The assessment of the said property under the said certificate issued was in the name of

EST OF IOLA JOHNSON

Unless said certificate shall be redeemed according to law, the property described therein will be sold to the highest bidder at the courthouse door at 9:00 A.M. on the **first** Tuesday in the month of September, which is the **3rd** day of **September 2013**.

Dated this 1st day of August 2013.

In accordance with the AMERICANS WITH DISABILITIES ACT, if you are a person with a disability who needs special accommodation in order to participate in this proceeding you are entitled to the provision of certain assistance. Please contact Maryline Avila not later than seven days prior to the proceeding at Escambia County Government Complex, 221 Palafox Place Ste 110, Pensacola FL 32502. Telephone: 850-595-3793.

Personal Services:

EST OF IOLA JOHNSON
2920 N F ST
PENSACOLA, FL 325

PAM CHILDERS
CLERK OF THE CIRCUIT COURT
ESCAMBIA COUNTY, FLORIDA

By:

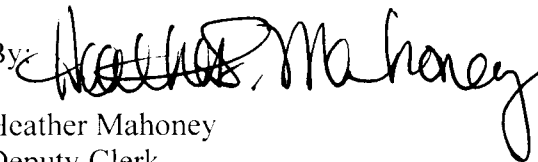
Heather Mahoney
Deputy Clerk



WARNING

THERE ARE UNPAID TAXES ON PROPERTY WHICH YOU OWN OR IN WHICH YOU HAVE A LEGAL INTEREST. THE PROPERTY WILL BE SOLD AT PUBLIC AUCTION ON September 3, 2013, UNLESS THE TAXES ARE PAID. SHOULD YOU NEED FURTHER INFORMATION CONTACT THE CLERK OF THE CIRCUIT COURT IMMEDIATELY AT THE COUNTY COURTHOUSE IN PENSACOLA, FLORIDA, OR CALL 850-595-3793.

NOTICE OF APPLICATION FOR TAX DEED

NOTICE IS HEREBY GIVEN, That **TAX LIEN FUND I, LP** holder of **Tax Certificate No. 04118**, issued the **1st** day of **June, A.D., 2009** has filed same in my office and has made application for a tax deed to be issued thereon. Said certificate embraces the following described property in the County of Escambia. State of Florida, to wit:

LTS 1 2 BLK 53 DB 555 P 772 ENGLEWOOD HEIGHTS PLAT DB 59 P 107

SECTION 18, TOWNSHIP 2 S, RANGE 30 W

TAX ACCOUNT NUMBER 062953000 (13-599)

The assessment of the said property under the said certificate issued was in the name of

EST OF IOLA JOHNSON

Unless said certificate shall be redeemed according to law, the property described therein will be sold to the highest bidder at the courthouse door at 9:00 A.M. on the **first** Tuesday in the month of September, which is the **3rd day of September 2013**.

Dated this 1st day of August 2013.

In accordance with the AMERICANS WITH DISABILITIES ACT, if you are a person with a disability who needs special accommodation in order to participate in this proceeding you are entitled to the provision of certain assistance. Please contact Maryline Avila not later than seven days prior to the proceeding at Escambia County Government Complex, 221 Palafox Place Ste 110, Pensacola FL 32502. Telephone: 850-595-3793.

PAM CHILDERS
CLERK OF THE CIRCUIT COURT
ESCAMBIA COUNTY, FLORIDA

Post Property:

2920 N F ST 32501

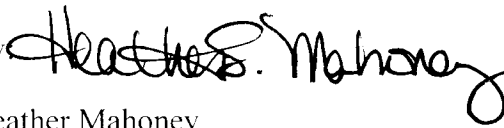
By 
Heather Mahoney
Deputy Clerk

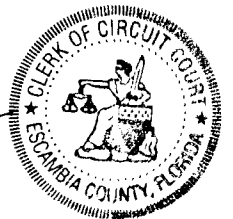

7011 3500 0002 5021 9185

U.S. Postal Service™
CERTIFIED MAIL™ RECEIPT
(Domestic Mail Only; No Insurance Coverage Provided)

For delivery information visit our website at www.usps.com®

OFFICIAL USE

Postage	\$ 0.46
Certified Fee	3.10
Return Receipt Fee (Endorsement Required)	2.55
Restricted Delivery Fee (Endorsement Required)	

Postmark
Here

611

St	EST OF IOLA JOHNSON [13-599]	
St	2920 N F ST	
or		
Ci	PENSACOLA, FL 325	

PS Form 3800, August 2006

See Reverse for Instructions

2009 TD 04118

SENDER: COMPLETE THIS SECTION

- Complete items 1, 2, and 3. Also, complete item 4 if Restricted Delivery is desired.
- Print your name and address on the reverse so that we can return the card to you.
- Attach this card to the back of the mailpiece, or on the front if space permits.

1. Article Addressed to:

EST OF IOLA JOHNSON [13-599]
2920 N F ST
PENSACOLA, FL 325

COMPLETE THIS SECTION ON DELIVERY

A. Signature Agent
 Angela King Addressee

B. Received by (Printed Name) C. Date of Delivery
Angela King *5/5/13*

D. Is delivery address different from item 1? Yes
If YES, enter delivery address below: No

3. Service Type
 Certified Mail Express Mail
 Registered Return Receipt for Merchandise
 Insured Mail C.O.D.

4. Restricted Delivery? (Extra Fee) Yes

2. Article Number
(Transfer from service label)

7011 3500 0002 5021 9185

PS Form 3811, February 2004

Domestic Return Receipt

102595-02-M-1540

ESCAMBIA COUNTY SHERIFF'S OFFICE
ESCAMBIA COUNTY, FLORIDA

NON-ENFORCEABLE RETURN OF SERVICE

Document Number: ECSO13CIV037238NON

Agency Number: 13-011215

Court: TAX DEED

County: ESCAMBIA

Case Number: CERT NO 04118, 2009

Attorney/Agent:

PAM CHILDERS
CLERK OF COURT
TAX DEEDS

Plaintiff: RE: EST OF IOLA JOHNSON

Defendant:

Type of Process: NOTICE OF APPLICATION FOR TAX DEED

Received this Writ on 7/31/2013 at 11:55 AM and served same at 11:10 AM on 8/7/2013 in ESCAMBIA COUNTY, FLORIDA, by serving POST PROPERTY , the within named, to wit: , .

POSTED PROPERTY PER INSTRUCTIONS FROM CLERK'S OFFICE.

DAVID MORGAN, SHERIFF
ESCAMBIA COUNTY, FLORIDA

By: _____



V. BELL, CPS

Service Fee: \$40.00

Receipt No: BILL

Printed By: JLBRYANT

011213

WARNING

THERE ARE UNPAID TAXES ON PROPERTY WHICH YOU OWN OR IN WHICH YOU HAVE A LEGAL INTEREST. THE PROPERTY WILL BE SOLD AT PUBLIC AUCTION ON September 3, 2013, UNLESS THE TAXES ARE PAID. SHOULD YOU NEED FURTHER INFORMATION CONTACT THE CLERK OF THE CIRCUIT COURT IMMEDIATELY AT THE COUNTY COURTHOUSE IN PENSACOLA, FLORIDA, OR CALL 850-595-3793.

NOTICE OF APPLICATION FOR TAX DEED

NOTICE IS HEREBY GIVEN, That **TAX LIEN FUND I, LP** holder of **Tax Certificate No. 04118**, issued the **1st** day of **June, A.D., 2009** has filed same in my office and has made application for a tax deed to be issued thereon. Said certificate embraces the following described property in the County of Escambia, State of Florida, to wit:

LTS 1 2 BLK 53 DB 555 P 772 ENGLEWOOD HEIGHTS PLAT DB 59 P 107

SECTION 18, TOWNSHIP 2 S, RANGE 30 W

TAX ACCOUNT NUMBER 062953000 (13-599)

The assessment of the said property under the said certificate issued was in the name of

EST OF IOLA JOHNSON

Unless said certificate shall be redeemed according to law, the property described therein will be sold to the highest bidder at the courthouse door at 9:00 A.M. on the **first** Tuesday in the month of September, which is the **3rd day of September 2013**.

Dated this 1st day of August 2013.

In accordance with the AMERICANS WITH DISABILITIES ACT, if you are a person with a disability who needs special accommodation in order to participate in this proceeding you are entitled to the provision of certain assistance. Please contact Maryline Avila not later than seven days prior to the proceeding at Escambia County Government Complex, 221 Palafox Place Ste 110, Pensacola FL 32502. Telephone: 850-595-3793.

PAM CHILDERS
CLERK OF THE CIRCUIT COURT
ESCAMBIA COUNTY, FLORIDA

Post Property:

2920 N F ST 32501

By

Heather Mahoney

Heather Mahoney
Deputy Clerk

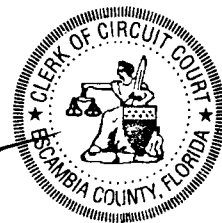

ESCAMBIA COUNTY SHERIFF'S OFFICE
ESCAMBIA COUNTY, FLORIDA

NON-ENFORCEABLE RETURN OF SERVICE

Document Number: ECSO13CIV037165NON

Agency Number: 13-011134

Court: TAX DEED

County: ESCAMBIA

Case Number: CERT NO 04118, 2009

Attorney/Agent:

PAM CHILDERS
CLERK OF COURT
TAX DEEDS

Plaintiff: RE: EST OF IOLA JOHNSON

Defendant:

Type of Process: NOTICE OF APPLICATION FOR TAX DEED

Non-Executed

Received this Writ on 7/31/2013 at 11:50 AM and after a diligent search in ESCAMBIA COUNTY, FLORIDA for EST OF IOLA JOHNSON , Writ was returned to court UNEXECUTED on 8/9/2013 for the following reason:

AFTER SEVERAL ATTEMPTS, UNABLE TO MAKE CONTACT WITH ANYONE AT 2920 NORTH "F" STREET PRIOR TO SERVE BY DATE. NO ADDITIONAL INFORMATION GAINED THROUGH DUE DILIGENCE EFFORTS.

DAVID MORGAN, SHERIFF
ESCAMBIA COUNTY, FLORIDA

By: _____

V. Bell

V. BELL, CPS

Service Fee: \$40.00
Receipt No: BILL

Printed By: NDCURRAN

W A R N I N G

THERE ARE UNPAID TAXES ON PROPERTY WHICH YOU OWN OR IN WHICH YOU HAVE A LEGAL INTEREST. THE PROPERTY WILL BE SOLD AT PUBLIC AUCTION ON September 3, 2013, UNLESS THE TAXES ARE PAID. SHOULD YOU NEED FURTHER INFORMATION CONTACT THE CLERK OF THE CIRCUIT COURT IMMEDIATELY AT THE COUNTY COURTHOUSE IN PENSACOLA, FLORIDA, OR CALL 850-595-3793.

NOTICE OF APPLICATION FOR TAX DEED

NOTICE IS HEREBY GIVEN, That **TAX LIEN FUND I**, LP holder of **Tax Certificate No. 04118**, issued the **1st** day of **June, A.D., 2009** has filed same in my office and has made application for a tax deed to be issued thereon. Said certificate embraces the following described property in the County of Escambia, State of Florida, to wit:

LTS 1 2 BLK 53 DB 555 P 772 ENGLEWOOD HEIGHTS PLAT DB 59 P 107

SECTION 18, TOWNSHIP 2 S, RANGE 30 W

TAX ACCOUNT NUMBER 062953000 (13-599)

The assessment of the said property under the said certificate issued was in the name of

EST OF IOLA JOHNSON

Unless said certificate shall be redeemed according to law, the property described therein will be sold to the highest bidder at the courthouse door at 9:00 A.M. on the **first** Tuesday in the month of September, which is the **3rd** day of **September 2013**.

Dated this 1st day of August 2013.

In accordance with the AMERICANS WITH DISABILITIES ACT, if you are a person with a disability who needs special accommodation in order to participate in this proceeding you are entitled to the provision of certain assistance. Please contact Maryline Avila not later than seven days prior to the proceeding at Escambia County Government Complex, 221 Palafox Place Ste 110, Pensacola FL 32502. Telephone: 850-595-3793.

Personal Services:

EST OF IOLA JOHNSON
2920 N F ST
PENSACOLA, FL 325

PAM CHILDERS
CLERK OF THE CIRCUIT COURT
ESCAMBIA COUNTY, FLORIDA

By:

Heather Mahoney
Heather Mahoney
Deputy Clerk





Pam Childers

Clerk of the Circuit Court and Comptroller, Escambia County

Clerk of Courts • County Comptroller • Clerk of the Board of County Commissioners • Recorder •

13-599

August 14, 2013

TAXLIEN FUND I LP
PO BOX 1074
ELMHURST IL 60126

Dear Certificate Holder:

The records of this office show that an application for a tax deed had been made on the property represented by the numbered certificate listed below. The property redeemed prior to sale; therefore your application fees are now refundable.

TAX CERT	APP FEES	INTEREST	TOTAL
2009 TD 004118	\$401.00	\$48.12	\$449.12

TOTAL \$449.12

Very truly yours,

PAM CHILDERS
Clerk of Circuit Court

By:

Emily Hogg
Tax Deed Division



Pam Childers

13-599

Clerk of the Circuit Court and Comptroller, Escambia County

Clerk of Courts • County Comptroller • Clerk of the Board of County Commissioners • Recorder •

August 14, 2013

Kevin Watts
2920 N F St
Pensacola FL 32501

Dear Kevin Watts,

The records of this office show that an application for a tax deed had been made on the property represented by the numbered certificate listed below. The property was redeemed by you. A refund of unused fees/interest is enclosed.

If you have any questions, please feel free to give me a call.

CERT NO

REFUND

04118/2009

\$141.37

TOTAL \$141.37

Very truly yours,

PAM CHILDERS
Clerk of Circuit Court

By:

Emily Hogg

Tax Deed Division

Redeemed From Sale

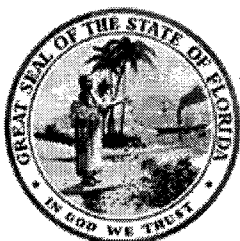

PAM CHILDERS CLERK OF THE CIRCUIT COURT ESCAMBIA COUNTY, FLORIDA

Tax Deed - Redemption Calculator

Account: 062953000 Certificate Number: 004118 of 2009

Redemption	<input type="checkbox"/> Yes	Application Date	<input type="text" value="12/07/2012"/>	Interest Rate	<input type="text" value="18%"/>
		Final Redemption Payment	ESTIMATED	Redemption Overpayment	ACTUAL
		Auction Date	<input type="text" value="09/03/2013"/>	Redemption Date	<input type="text" value="08/08/2013"/>
Months	9			8	
Tax Collector	<input type="text" value="\$6,357.07"/>			<input type="text" value="\$6,357.07"/>	
Tax Collector Interest	\$858.20			\$762.85	
Tax Collector Fee	<input type="text" value="\$6.25"/>			<input type="text" value="\$6.25"/>	
Total Tax Collector	\$7,221.52			<input type="text" value="\$7,126.17"/>	TC
Clerk Fee	<input type="text" value="\$60.00"/>			<input type="text" value="\$60.00"/>	
Sheriff Fee	<input type="text" value="\$120.00"/>			<input type="text" value="\$120.00"/>	
Legal Advertisement	<input type="text" value="\$221.00"/>			<input type="text" value="\$221.00"/>	
App. Fee Interest	\$54.14			\$48.12	
Total Clerk	\$455.14			<input type="text" value="\$449.12"/>	CH
Postage	<input type="text" value="\$6.11"/>			<input type="text" value="\$6.11"/>	
Researcher Copies	<input type="text" value="\$5.00"/>			<input type="text" value="\$5.00"/>	
Total Redemption Amount	\$7,687.77			\$7,586.40	
		Repayment Overpayment Refund Amount		\$101.37	+40.00 = \$141.37

Notes ACTUAL SHERIFF \$80.00 COM FEE \$18.50
 1/24/2013 kevin(grandson of owner) called for redemption
 quote...mva 8-8-2013 cert mail for iola Johnson signed by

PAM CHILDERS
 CLERK OF THE CIRCUIT COURT
 ARCHIVES AND RECORDS
 CHILDSUPPORT
 CIRCUIT CIVIL
 CIRCUIT CRIMINAL
 COUNTY CIVIL
 COUNTY CRIMINAL
 DOMESTIC RELATIONS
 FAMILY LAW
 JURY ASSEMBLY
 JUVENILE
 MENTAL HEALTH
 MIS
 OPERATIONAL SERVICES
 PROBATE
 TRAFFIC

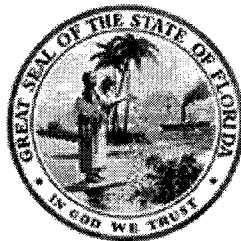

**COUNTY OF ESCAMBIA
 OFFICE OF THE
 CLERK OF THE CIRCUIT COURT**

**BRANCH OFFICES
 ARCHIVES AND RECORDS
 JUVENILE DIVISION
 CENTURY**

CLERK TO THE BOARD OF
 COUNTY COMMISSIONERS
 OFFICIAL RECORDS
 COUNTY TREASURY
 AUDITOR

**PAM CHILDERS, CLERK OF THE CIRCUIT COURT
 Tax Certificate Redeemed From Sale**

Account: 062953000 Certificate Number: 004118 of 2009

Payor: KEVIN WATTS 2920 N F ST PENSACOLA FL 32501 Date 08/08/2013

Clerk's Check # 6650600571
 Tax Collector Check # 1

Clerk's Total \$455.14
 Tax Collector's Total \$7,221.52
 Postage \$6.11
 Researcher Copies \$5.00
 Total Received \$7,687.77

**PAM CHILDERS
 Clerk of the Circuit Court**

Received By: _____
 Deputy Clerk

**Escambia County Government Complex • 221 Palafox Place Ste 110 • PENSACOLA, FLORIDA 32502
 (850) 595-3793 • FAX (850) 595-4827 • <http://www.clerk.co.escambia.fl.us>**

PAM CHILDERS
 CLERK OF THE CIRCUIT COURT
 ARCHIVES AND RECORDS
 CHILDSUPPORT
 CIRCUIT CIVIL
 CIRCUIT CRIMINAL
 COUNTY CIVIL
 COUNTY CRIMINAL
 DOMESTIC RELATIONS
 FAMILY LAW
 JURY ASSEMBLY
 JUVENILE
 MENTAL HEALTH
 MIS
 OPERATIONAL SERVICES
 PROBATE
 TRAFFIC

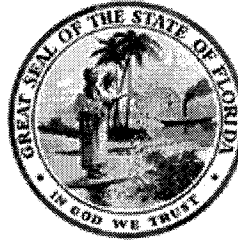

BRANCH OFFICES
ARCHIVES AND RECORDS
JUVENILE DIVISION
CENTURY

CLERK TO THE BOARD OF
 COUNTY COMMISSIONERS
 OFFICIAL RECORDS
 COUNTY TREASURY
 AUDITOR

COUNTY OF ESCAMBIA
OFFICE OF THE
CLERK OF THE CIRCUIT COURT

Case # 2009 TD 004118

Redeemed Date 08/08/2013

Name KEVIN WATTS 2920 N F ST PENSACOLA FL 32501

- Clerk's Total = TAXDEED \$455.14
- Due Tax Collector = TAXDEED \$7,221.52
- Postage = TD2 \$6.11
- ResearcherCopies = TD6 \$5.00

• For Office Use Only

Date	Docket	Desc	Amount Owed	Amount Due	Payee Name
06/01/2009	TD1	TAX DEED APPLICATION Receipt: 1481569 Date: 12/21/2012	60.00	0.00	
06/01/2009	TAXDEED	TAX DEED CERTIFICATES Receipt: 1481569 Date: 12/21/2012	341.00	0.00	
01/14/2013	TD83	TAX COLLECTOR CERTIFICATION	0.00	0.00	
03/11/2013	TD82	O & E REPORT	0.00	0.00	

FINANCIAL SUMMARY

Rcd	Docket Application	Owed	Paid	Dismissed	Due
1	Service Charge	\$60.00	\$60.00	\$0.00	\$0.00
2	Holding	\$341.00	\$341.00	\$0.00	\$0.00
TOTAL		\$401.00	\$401.00	\$0.00	\$0.00

Ernie Lee Magaha,
Clerk of the Circuit Court of Escambia County Florida

Receipt Type	Case	Outstanding Amount	0.00
Receipt Number	1481569	Receipt Date	12/21/2012

Case Number	2009 TD 004118
Description	TAX LIEN FUND I, LP VS

Action TAX DEED APPLICATION

Judge

Received From TAX LIEN FUND I, LP

On Behalf Of TAX LIEN FUND I, LP

Total Received	401.00
Net Received	401.00
Change	0.00

Receipt Payments	Amount	Reference Description
Check	401.00	7000000021

Receipt Applications	Amount
Holding	341.00
Service Charge	60.00

Deputy Clerk: mavila Transaction Date 12/21/2012 15:31:26

Comments



Chris Jones

Escambia County Property Appraiser

[Real Estate Search](#) |
 [Tangible Property Search](#) |
 [Amendment 1 Calculations](#)

[Back](#)

← **Navigate Mode** **Account**
→ **Reference**

Printer Friendly Version

General Information	
Reference:	182S306000001053
Account:	062953000
Owners:	JOHNSON IOLA EST OF
Mail:	2920 N F ST PENSACOLA, FL 32501
Situs:	2920 N F ST 32501
Use Code:	SINGLE FAMILY RESID
Taxing Authority:	ESCAMBIA COUNTY
Tax Inquiry:	Open Tax Inquiry Window
Tax Inquiry link courtesy of Janet Holley, Escambia County Tax Collector.	

2012 Certified Roll Assessment	
Improvements:	\$48,659
Land:	\$9,912
Total:	\$58,571
Save Our Homes:	\$0
Disclaimer	
Amendment 1 Calculations	

Sales Data	
Sale Date Book Page Value Type	Official Records (New Window)
None	
Official Records Inquiry courtesy of Ernie Lee Magaha, Escambia County Clerk of the Court	

2012 Certified Roll Exemptions	
None	
Legal Description	
LTS 1 2 BLK 53 DB 555 P 772 ENGLEWOOD HEIGHTS PLAT DB 59 P 107	

Extra Features
None

Parcel Information
[Restore Map](#)
[Get Map Image](#)
[Launch Interactive Map](#)

Section Map Id:
18-2S-30

Approx. Acreage:
0.1900

Zoned:
R-4

Evacuation & Flood Information
[Open Report](#)

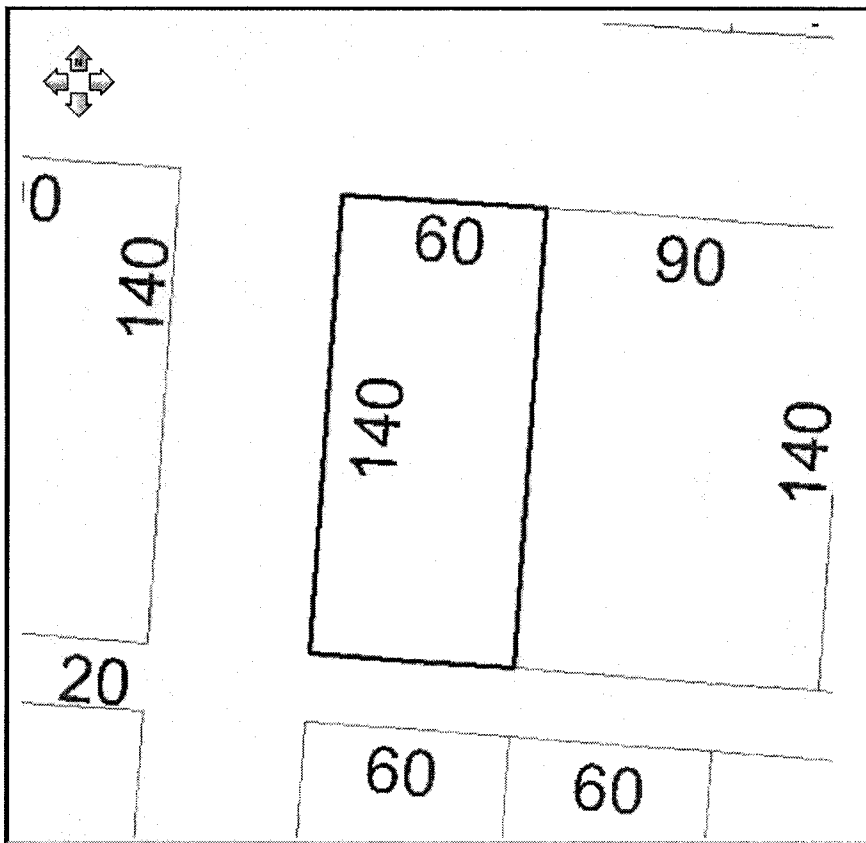

Buildings

Building 1 - Address:2920 N F ST, Year Built: 1961, Effective Year: 1961

Structural Elements

FOUNDATION-WOOD/NO SUB FLR
 EXTERIOR WALL-SIDING-SHT.AVG.
 NO. PLUMBING FIXTURES-3.00
 DWELLING UNITS-1.00
 ROOF FRAMING-GABLE
 ROOF COVER-COMPOSITION SHG
 INTERIOR WALL-DRYWALL-PLASTER
 FLOOR COVER-PINE/SOFTWOOD
 NO. STORIES-1.00
 DECOR/MILLWORK-AVERAGE
 HEAT/AIR-WALL/FLOOR FURN
 STRUCTURAL FRAME-WOOD FRAME

Areas - 1395 Total SF

BASE AREA - 1077
 CARPORT UNF - 216
 OPEN PORCH FIN - 102

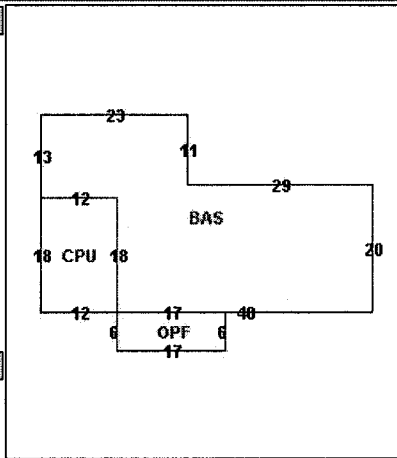

Building 2 - Address:2918 N F ST, Year Built: 1965, Effective Year: 1965

Structural Elements

FOUNDATION-WOOD/NO SUB FLR
 EXTERIOR WALL-SIDING-SHT.AVG.
 NO. PLUMBING FIXTURES-3.00
 DWELLING UNITS-1.00
 ROOF FRAMING-GABLE
 ROOF COVER-COMPOSITION SHG
 INTERIOR WALL-DRYWALL-PLASTER
 FLOOR COVER-PINE/SOFTWOOD
 NO. STORIES-1.00
 DECOR/MILLWORK-MINIMUM
 HEAT/AIR-WALL/FLOOR FURN
 STRUCTURAL FRAME-WOOD FRAME

Areas - 907 Total SF

BASE AREA - 827
 OPEN PORCH UNF - 80

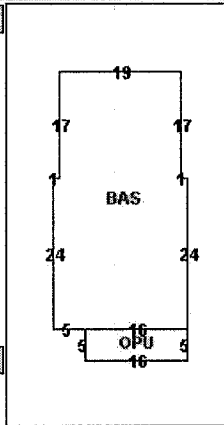

Images

None

The primary use of the assessment data is for the preparation of the current year tax roll. No responsibility or liability is assumed for inaccuracies or errors.

Last Updated: 01/08/2013 (tc.3334)

