

ERNIE LEE MAGAHA
CLERK OF THE CIRCUIT COURT



BRANCH OFFICES
ARCHIVES AND RECORDS
JUVENILE DIVISION

ARCHIVES AND RECORDS
CHILD SUPPORT
CIRCUIT CIVIL
CIRCUIT CRIMINAL
COUNTY CIVIL
COUNTY CRIMINAL
DOMESTIC RELATIONS
FAMILY LAW
JURY ASSEMBLY
JUVENILE
MENTAL HEALTH
MIS
OPERATIONAL SERVICES
PROBATE
TRAFFIC

**COUNTY OF ESCAMBIA
OFFICE OF THE
CLERK OF THE CIRCUIT COURT**

CLERK TO THE BOARD OF
COUNTY COMMISSIONERS

OFFICIAL RECORDS
COUNTY TREASURY
AUDITOR

CENTURY

IMAGING COVER PAGE

This cover page is not a part of the original documents but is necessary to avoid obscuring any information on the original documents

Case: 2009 TD 000600



00051331746

Dkt: TD83 Pg#:

3

Original Documents Follow

TAX COLLECTOR'S CERTIFICATION

**Application
Date / Number
Apr 22, 2011 / 110440**

This is to certify that the holder listed below of Tax Sale Certificate Number **2009 / 600** , issued the **1st day of June, 2009**, and which encumbers the following described property located in the County of Escambia, State of Florida to wit: **Parcel ID Number: 01-4569-000**

Certificate Holder:
RILEY DICK N & BETTY N TRUSTEE OF RILEY LIVING TRU
C/O M&F BANK
NICEVILLE, FLORIDA 32578

Property Owner:
WOOD EDMUND C
10002 CHEMSTRAND RD LOT 38
PENSACOLA, FLORIDA 32514

Legal Description: 07-1S3-023
LT 10 OR N1/2 OF S1/2 OF SW1/4 OF NW1/4 OR 1288 P 533 LESS OR 968 P 862 ARD

has surrendered same in my office and made written application for tax deed in accordance with Florida Statutes. I certify that the following tax certificates, interest, ownership and encumbrance report fee, and Tax Collector's fees have been paid:

CERTIFICATES OWNED BY APPLICANT AND FILED IN CONNECTION WITH THIS TAX DEED APPLICATION:

Cert. Year	Certificate Number	Date of Sale	Face Amt	T/C Fee	Interest	Total
2009	600	06/01/09	\$2,883.03	\$0.00	\$994.65	\$3,877.68

CERTIFICATES REDEEMED BY APPLICANT OR INCLUDED (COUNTY) IN CONNECTION WITH THIS APPLICATION:

Cert. Year	Certificate Number	Date of Sale	Face Amt	T/C Fee	Interest	Total
------------	--------------------	--------------	----------	---------	----------	-------

1. Total of all Certificates in Applicant's Possession and Cost of the Certificates Redeemed by Applicant or Included (County)
2. Total of Delinquent Taxes Paid by Tax Deed Application
3. Total of Current Taxes Paid by Tax Deed Applicant
4. Ownership and Encumbrance Report Fee
5. Tax Deed Application Fee
6. Total Certified by Tax Collector to Clerk of Court
7. Clerk of Court Statutory Fee
8. Clerk of Court Certified Mail Charge
9. Clerk of Court Advertising Charge
10. Sheriff's Fee
11. _____
12. Total of Lines 6 thru 11
13. Interest Computed by Clerk of Court Per Florida Statutes.....(%)
14. One-Half of the assessed value of homestead property. If applicable pursuant to section 197.502, F.S.
15. Statutory (Opening) Bid; Total of Lines 12 thru 14
16. Redemption Fee
17. Total Amount to Redeem

\$3,877.68
\$0.00
\$150.00
\$75.00
\$4,102.68
\$4,102.68
\$66,517.50
\$6.25

*Done this 22nd day of April, 2011

TAX COLLECTOR, ESCAMBIA COUNTY, FLORIDA

By Candice Lewis

Date of Sale: October 3, 2011

* This certification must be surrendered to the Clerk of the Circuit Court no later than ten days after this date.

Notice to Tax Collector of Application for Tax Deed

TO: Tax Collector of Escambia County

In accordance with Florida Statutes, I,

**RILEY DICK N & BETTY N TRUSTEE OF RILEY
LIVING TRU
C/O M&F BANK
NICEVILLE, Florida, 32578**

holder of the following tax sale certificate hereby surrender same to the Tax Collector and make tax deed application thereon:

Certificate No.	Parcel ID Number	Date	Legal Description
600	01-4569-000	06/01/2009	07-153-023 LT 10 OR N1/2 OF S1/2 OF SW1/4 OF NW1/4 OR 1288 P 533 LESS OR 968 P 862 ARD

2010 TAX ROLL

WOOD EDMUND C
10002 CHEMSTRAND RD LOT 38
PENSACOLA, Florida 32514

I agree to pay all delinquent taxes, redeem all outstanding certificates not in my possession, pay any omitted taxes, and pay current taxes, if due, covering the land, and pay any interest earned (a) on tax certificates not in my possession, (b) on omitted taxes or (c) on delinquent taxes. I also agree to pay all Tax Collector's fees, ownership and encumbrance reports costs, Clerk of the Court costs, charges and fees and Sheriff's costs, if applicable. Attached is the above-mentioned tax sale certificate on which this application is based and all other certificates of the same legal description which are in my possession.

dick668 (DICK RILEY)
Applicant's Signature

04/22/2011
Date

ERNIE LEE MAGAHA
CLERK OF THE CIRCUIT COURT



BRANCH OFFICES
ARCHIVES AND RECORDS
JUVENILE DIVISION

CENTURY

ARCHIVES AND RECORDS
CHILD SUPPORT
CIRCUIT CIVIL
CIRCUIT CRIMINAL
COUNTY CIVIL
COUNTY CRIMINAL
DOMESTIC RELATIONS
FAMILY LAW
JURY ASSEMBLY
JUVENILE
MENTAL HEALTH
MIS
OPERATIONAL SERVICES
PROBATE
TRAFFIC

**COUNTY OF ESCAMBIA
OFFICE OF THE
CLERK OF THE CIRCUIT COURT**

CLERK TO THE BOARD OF
COUNTY COMMISSIONERS

OFFICIAL RECORDS
COUNTY TREASURY
AUDITOR

IMAGING COVER PAGE

This cover page is not a part of the original documents but is necessary to avoid obscuring any information on the original documents

Case: 2009 TD 000600



00045509694

Dkt: TD82 Pg#:

6

Original Documents Follow

Southern Guaranty Title Company

4400 Bayou Boulevard, Suite 13B

Pensacola, Florida 32503

Telephone: 850-478-8121

Facsimile: 850-476-1437

OWNERSHIP AND ENCUMBRANCE REPORT

File No.: 8855

May 16, 2011

Escambia County Tax Collector
P.O. Box 1312
Pensacola, Florida 32569

Pursuant to your request, the Company has caused a search to be made of the Public Records of Escambia County, Florida, solely as revealed by records maintained from 05-16-91, through 05-16-11, and said search reveals the following:

1. THE GRANTEE(S) OF THE LAST DEED(S) OF RECORD IS:

Edmund C. Wood

2. The land covered by this Report is:

LEGAL DESCRIPTION IS ATTACHED HERETO AND MADE A PART HEREOF

3. The following unsatisfied mortgages, liens and judgments affecting the land covered by this Report appear of record:

SEE CONTINUATION PAGE ATTACHED HERETO AND MADE A PART HEREOF

4. Taxes:

SEE CONTINUATION PAGE ATTACHED HERETO AND MADE A PART HEREOF

The foregoing report is prepared and furnished for information only, is not intended to constitute or imply any opinion, warranty, guaranty, insurance, or similar assurance as to the status of title, and no determination has been made of the authenticity of any instrument described or referred to herein. The name search for the purposes of determining applicable judgments and liens is limited to the apparent record owner(s) shown herein. No attempt has been made to determine whether the land is subject to liens or assessments which are not shown as existing liens by the public records. The Company's liability hereunder shall not exceed the cost of this Report, or \$1,000.00 whichever is less.

THIS REPORT SHALL NOT BE USED FOR THE ISSUANCE OF TITLE INSURANCE.

Southern Guaranty Title Company

By: 

May 16, 2011

**OWNERSHIP AND ENCUMBRANCE REPORT
LEGAL DESCRIPTION**

File No.: 8855

May 16, 2011

Lot 10 or North 1/2 of South 1/2 of Southwest 1/4 of Northwest 1/4, O.R. Book 1288,
page 533, Less O.R. Book 968, page 862, Ard.

**OWNERSHIP AND ENCUMBRANCE REPORT
CONTINUATION PAGE**

File No.: 8855

May 16, 2011

UNSATISFIED MORTGAGES, LIENS AND JUDGMENTS AFFECTING THE LAND COVERED BY THIS REPORT THAT APPEAR OF RECORD:

1. MSBU Lien filed by Escambia County recorded in O.R. Book 4423, page 1888, and O.R. Book 4312, page 1131.
2. Taxes for the year 2008 delinquent. The assessed value is \$133,035.00. Tax ID 01-4569-000.

PLEASE NOTE THE FOLLOWING:

- A. Taxes and assessments due now or in subsequent years.
- B. Subject to Easements, Restrictions and Covenants of record.
- C. Oil, gas, mineral or any other subsurface rights of any kind or nature.
- D. Encroachments, overlaps, boundary line disputes, and any other matters which would be disclosed by an accurate survey and inspection of the premises.

SOUTHERN GUARANTY TITLE COMPANY

4400 BAYOU BLVD., SUITE 13-B, CORDOVA SQUARE

PENSACOLA, FLORIDA 32503

TEL. (850) 478-8121 FAX (850) 476-1437

Email: rcsgr@aol.com

Janet Holley
Escambia County Tax Collector
P.O. Box 1312
Pensacola, FL 32596

CERTIFICATION: TITLE SEARCH FOR TDA

TAX DEED SALE DATE: 10-3-11

TAX ACCOUNT NO.: 01-4569-000

CERTIFICATE NO.: 2009_600

In compliance with Section 197.256, Florida Statutes, the following is a list of names and addresses of those persons, firms and/or agencies having legal interest in or claim against the above described property. The above referenced tax sale certificate is being submitted as proper notification of tax deed sale.

YES NO

- Notify City of Pensacola, P.O. Box 12910, 32596
- Notify Escambia County, ^{221 Palafox Place/} 190 Governmental Center, 32501
- Homestead for 2010 tax year.

Edmund C. Wood
10002 Chenstrand Rd. Lot 38
Pensacola, FL 32514

Certified and delivered to Escambia County Tax Collector,
this 17th day of May, 2011.

SOUTHERN GUARANTY TITLE COMPANY

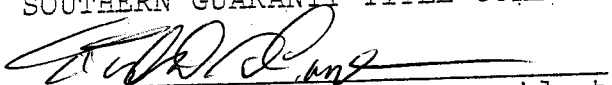
by: Richard S. Combs, President

NOTE: The above listed addresses are based upon current information available, but said addresses are not guaranteed to be true or correct.

1330
7872
18 1/2
80 05

Prepared by: William L. Lee, Jr., of
Shell, Fleming, Davis & Menge
Seventh Floor--Seville Tower
Post Office Box 1831
Pensacola, Florida 32598
S.F.D.&M. File # L 13-1208

STATE OF FLORIDA
COUNTY OF ESCAMBIA

OFFREC
BOOK 1288 PAGE 533

Rt. 5, Box 690 - Pensacola, Florida

WARRANTY DEED

KNOW ALL MEN BY THESE PRESENTS: Frank W. Lowery, a divorced and unmarried man, and as natural father and guardian of the child, Frank W. Lowery, Jr., pursuant to Florida Statute 744.301(2) and Virginia I. Lowery, a/k/a Virginia Lowery, a divorced and unmarried woman; Virginia I. Lowery, as the natural guardian of the child, Frank W. Lowery, pursuant to Florida Statute 744.301(2); and Teresa J. Lowery, joined by her husband, Joseph Powell, and Frank W. Lowery, joined by her husband, Joseph Powell, as the owners of the aforesaid property, having rights to the below described property as a result of that certain Final Judgment dissolving the marriage of Frank W. Lowery, husband, and Virginia I. Lowery, wife, entered on the 17th day of May, 1978, by the Honorable William H. Williams, Jr., of the Circuit Court in and for Escambia County, Florida, Case No. 78-1111-CA-01, which incorporated by reference, a certain Support Agreement setting forth the aforesaid property, the below described real property, all of the being owned by the Grantors, for and in consideration of One Dollar and no other valuable considerations, the receipt whereof is hereby acknowledged, do bargain, sell, convey and grant to Frank W. Lowery, Jr., a minor man, hereinafter called Grantee, his heirs, assigns, successors and assigns, forever, the real property located in Escambia County, Florida, more particularly described as:

The North One-Half of the South One-Half of the Southwest Quarter of the Northwest Quarter of Section 7, Township 1 South, Range 18 West, Escambia County, Florida, excepting therefrom all other property excepting therefrom that portion of the above described property as shown in the plat of the same recorded in the Official Record Book No. 1288, Page 862 of the Public Records of Escambia County, Florida, more fully described as follows: Commencing at the Northwest corner of Lot 1, Chestnut Street, Plat Book 6, Page 81; thence westerly along an extension of the North line of said subdivision, 135 feet to the Easterly right-of-way line of State Road 292 (100 foot R/W); thence South along said right-of-way 271.28 feet to the Point of Beginning; thence 90 degrees left 489.3 feet; thence deflect 91 degrees 05 minutes right 464.02 feet; thence deflect 88 degrees 55 minutes right 464.02 feet; thence 90 degrees right 290.80 feet to the Point of Beginning.

The undersigned do also attest that the abovestated minors' (Frank W. Lowery, Jr., and Teresa J. Lowery) interest in the above property is less than \$5,000 in value and pursuant to Florida Statute 744.301(2).

SUBJECT to taxes for the current year and to bound easements and restrictions of record affecting the above property, if any, which are not hereby reimposed.

To have and to hold, unto the said Grantee, his heirs, successors and assigns, forever, together with all and singular the tenements, hereditaments and appurtenances thereto belonging or in anywise appertaining.

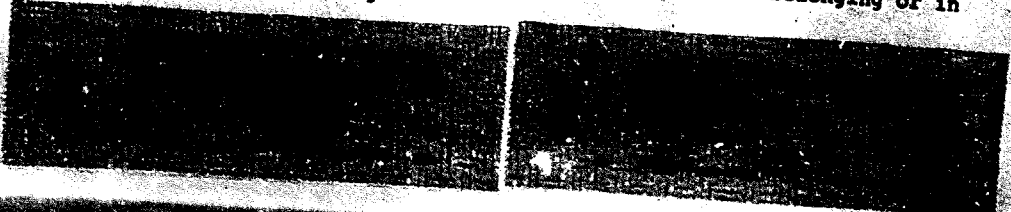

**Ernie Lee Magaha,
Clerk of the Circuit Court of Escambia County Florida**

Receipt Type	Case	Outstanding Amount	0.00
Receipt Number	1281585	Receipt Date	05/03/2011

Case Number	2009 TD 000600
Description	DICK N & BETTY N RILEY TRUSTEES OF THE RILEY LIVIN VS

Action **TAX DEED APPLICATION**

Judge

Received From **DICK N & BETTY N RILEY TRUSTEES OF THE R**

On Behalf Of **DICK N & BETTY N RILEY TRUSTEES OF THE
RILEY LIVIN**

Total Received	390.00
Net Received	390.00
Change	0.00

Receipt Payments	Amount	Reference	Description
Check	390.00	106	

Receipt Applications	Amount
Holding	330.00
Service Charge	60.00

Deputy Clerk: nlk Transaction Date 05/03/2011 16:06:43

Comments



Chris Jones

Escambia County Property Appraiser

[Real Estate Search](#)

[Tangible Property Search](#)

[Amendment 1 Calculations](#)

[Back](#)



Navigate Mode

Account

Reference



[Printer Friendly Version](#)

General Information	
Reference:	071S302310000000
Account:	014569000
Owners:	WOOD EDMUND C
Mail:	10002 CHEMSTRAND RD LOT 38 PENSACOLA, FL 32514
Situs:	10002 CHEMSTRAND RD 32514
Use Code:	PARKING/MH PARK
Taxing Authority:	COUNTY MSTU
Tax Inquiry:	Open Tax Inquiry Window
Tax Inquiry link courtesy of Janet Holley, Escambia County Tax Collector	

2010 Certified Roll Assessment	
Improvements:	\$160,622
Land:	\$118,940
Total:	\$279,562
<i>Save Our Homes:</i>	\$133,035
Disclaimer	
Amendment 1 Calculations	

Sales Data					
Sale Date	Book	Page	Value	Type	Official Records (New Window)
01/1979	1288	533	\$16,300	WD	View Instr
01/1973	664	903	\$27,000	WD	View Instr
01/1972	600	340	\$100	QC	View Instr
01/1972	596	435	\$2,200	QC	View Instr
Official Records Inquiry courtesy of Ernie Lee Magaha, Escambia County Clerk of the Court					

2010 Certified Roll Exemptions	
HOMESTEAD EXEMPTION	
Legal Description	
LT 10 OR N1/2 OF S1/2 OF SW1/4 OF NW1/4 OR 1288 P 533 LESS OR 968 P 862 ARD	
Extra Features	
CARPORT	
MOBILE HOME	
MOBILE HOME ADDITION	
POOL	
SITE VALUE	
WOOD DECK	

Parcel Information

[Restore Map](#)

[Get Map Image](#)

[Launch Interactive Map](#)

Section Map Id:
07-1S-30-2

Approx. Acreage:
3.1400

Zoned:
R-6



CHEMSTRAND RD



132.6

2310-2

2500-28

132.64

2900-27

2500-26

2500-25

2500-24

2310-3

2310

290

2309

15

563.74

2308-2-1



Buildings

Building 1 - Address: 10002 CHEMSTRAND RD, Year Built: 1950, Effective Year: 1975

Structural Elements

FOUNDATION-WOOD/SUB FLOOR
EXTERIOR WALL-SIDING-SHT.AVG.
NO. PLUMBING FIXTURES-6.00
DWELLING UNITS-13.00
ROOF FRAMING-GABL/HIP COMBO
ROOF COVER-COMPOSITION SHG
INTERIOR WALL-DRYWALL-PLASTER
FLOOR COVER-CARPET
NO. STORIES-1.00
FLOOR COVER-CARPET
DECOR/MILLWORK-AVERAGE
HEAT/AIR-CENTRAL H/AC
STRUCTURAL FRAME-WOOD FRAME

Areas - 2466 Total SF

BASE AREA - 1694
GARAGE FIN - 384
OPEN PORCH FIN - 188
OPEN PORCH UNF - 200

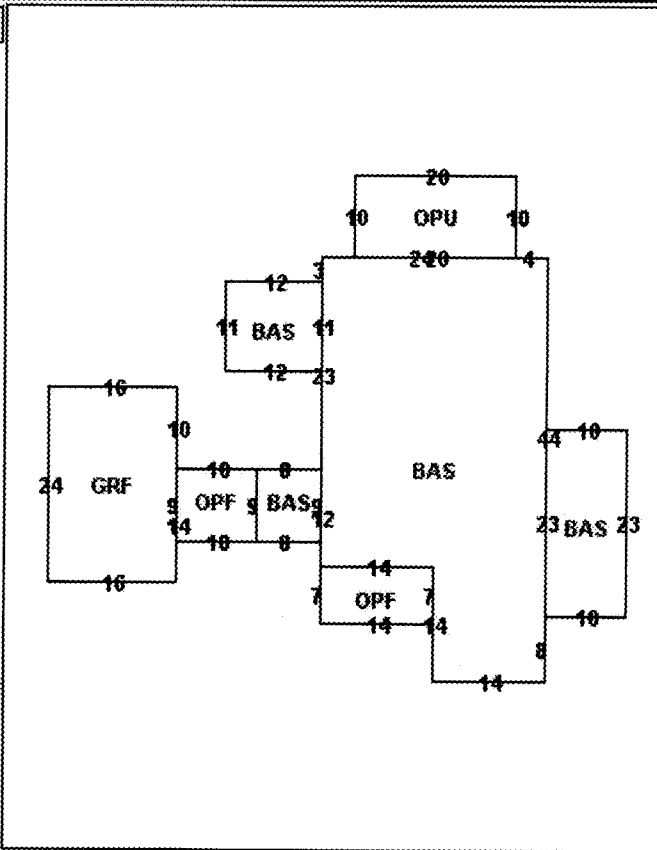

Images

None

The primary use of the assessment data is for the preparation of the current year tax roll. No responsibility or liability is assumed for inaccuracies or errors.

ERNIE LEE MAGAHA
 CLERK OF THE COURT & COMPTROLLER
 P.O. BOX 333
 PENSACOLA, FL 32591-0333
 (850) 595-4140
 REGISTRY ACCOUNT

Bank of America
 PENSACOLA, FLOR
 VOID AFTER 6 MONTHS

9000014632

63-27
 631

PAY

*TEN THOUSAND FOUR HUNDRED FORTY TWO AND 26/100

JANET HOLLEY TAX COLLECTOR

TO THE
 ORDER
 OF

JANET HOLLEY TAX COLLECTOR
 213 PALAFOX PLACE
 PENSACOLA, FL 32502

DATE

AMOUNT

07/19/2011

10,442.26

Ernie Lee Magaha

ERNIE LEE MAGAHA, CLERK OF THE COURT



⑈9000014632⑈ ⑆063100277⑆ 898033991356⑈

ERNIE LEE MAGAHA
 CLERK OF THE COURT & COMPTROLLER

9000014632

Date	Case Number	Description	Amount
07/19/2011	2009 TD 000600	PAYMENT TAX DEEDS	4,293.55
07/19/2011	2009 TD 003444	PAYMENT TAX DEEDS	4,739.67
07/19/2011	2009 TD 010751	PAYMENT TAX DEEDS	1,409.04

9000014632

Check: 9000014632 07/19/2011 JANET HOLLEY TAX COLLECTOR

Check Amount:

10,442.26

Candice Lewis 7-19-11

ERNIE LEE MAGAHA
CLERK OF THE COURT & COMPTROLLER
P.O. BOX 333
PENSACOLA, FL 32591-0333
(850) 595-4140
REGISTRY ACCOUNT

Bank of America
PENSACOLA, FLORIDA
VOID AFTER 6 MONTHS

9000014624

63-27
631

PAY

*FOUR HUNDRED SEVEN AND 55/100

DICK N AND BETTY N RILEY TRUSTEES

TO THE ORDER OF
DICK N AND BETTY N RILEY TRUSTEES
C/O M&P BANK
750 JOHN SIMS PKWY
NICEVILLE, FL 32578

DATE
07/19/2011

AMOUNT
407.55

Ernie Lee Magaha

ERNIE LEE MAGAHA, CLERK OF THE COURT



⑈9000014624⑈ ⑆063100277⑆ 898033991356⑈

ERNIE LEE MAGAHA
CLERK OF THE COURT & COMPTROLLER

9000014624

<u>Date</u>	<u>Case Number</u>	<u>Description</u>	<u>Amount</u>
07/19/2011	2009 TD 000600	PAYMENT TAX DEEDS	407.55

9000014624

Check: 9000014624 07/19/2011 DICK N AND BETTY N RILEY TRUSTEES Check Amount: 407.55

THE REVERSE SIDE OF THIS DOCUMENT INCLUDES MICROPRINTED RESPONSES, FIBERS AND ARTIFICIAL WATERMARK. HOLD AT AN ANGLE TO VIEW.

ERNIE LEE MAGAHA
CLERK OF THE COURT & COMPTROLLER
P.O. BOX 333
PENSACOLA, FL 32591-0333
(850) 595-4140
REGISTRY ACCOUNT

Bank of America 
PENSACOLA, FLORIDA 63-27
631
VOID AFTER 6 MONTHS

9000014625

PAY

*FIVE HUNDRED THIRTY TWO AND 17/100

EDMUND C WOOD

TO THE ORDER OF
EDMUND C WOOD
10002 CHEMSTRAND
PENSACOLA, FL 32514

DATE: 07/19/2011
AMOUNT: 532.17

Ernie Lee Magaha

ERNIE LEE MAGAHA, CLERK OF THE COURT



⑈9000014625⑈ ⑆063100277⑆ 898033991356⑈

ERNIE LEE MAGAHA
CLERK OF THE COURT & COMPTROLLER

9000014625

<u>Date</u>	<u>Case Number</u>	<u>Description</u>	<u>Amount</u>
07/19/2011	2009 TD 000600	PAYMENT TAX DEEDS	532.17

9000014625

Check: 9000014625 07/19/2011 EDMUND C WOOD

Check Amount: 532.17



ERNIE LEE MAGAHA CLERK OF THE CIRCUIT COURT ESCAMBIA COUNTY, FLORIDA

Tax Deed - Redemption Calculator
 Account: 014569000 Certificate Number: 000600 of 2009

Redemption Yes
 Application Date
 Interest Rate

	Final Redemption Payment ESTIMATED	Redemption Overpayment ACTUAL
	Auction Date <input type="text" value="10/03/2011"/>	Redemption Date <input type="text" value="07/18/2011"/> <input type="checkbox"/>
Months	6	3
Tax Collector	<input type="text" value="\$4,102.68"/>	<input type="text" value="\$4,102.68"/>
Tax Collector Interest	\$369.24	\$184.62
Tax Collector Fee	<input type="text" value="\$6.25"/>	<input type="text" value="\$6.25"/>
Total Tax Collector	\$4,478.17	\$4,293.55
Clerk Fee	<input type="text" value="\$60.00"/>	<input type="text" value="\$60.00"/>
Sheriff Fee	<input type="text" value="\$120.00"/>	<input type="text" value="\$120.00"/>
Legal Advertisement	<input type="text" value="\$210.00"/>	<input type="text" value="\$210.00"/>
App. Fee Interest	\$35.10	\$17.55
Total Clerk	\$425.10	\$407.55
Postage	<input type="text" value="\$12.00"/>	<input type="text" value="\$12.00"/>
Researcher Copies	<input type="text" value="\$5.00"/>	<input type="text" value="\$5.00"/>
Total Redemption Amount	\$4,920.27	\$4,718.10
	Repayment Overpayment Refund Amount	$\$202.17 + 240 + 120 = 532.17$

Notes

ERNIE LEE MAGAHA
CLERK OF THE CIRCUIT COURT
ARCHIVES AND RECORDS
CHILDSUPPORT
CIRCUIT CIVIL
CIRCUIT CRIMINAL
COUNTY CIVIL
COUNTY CRIMINAL
DOMESTIC RELATIONS
FAMILY LAW
JURY ASSEMBLY
JUVENILE
MENTAL HEALTH
MIS
OPERATIONAL SERVICES
PROBATE
TRAFFIC



**COUNTY OF ESCAMBIA
OFFICE OF THE
CLERK OF THE CIRCUIT COURT**

**BRANCH OFFICES
ARCHIVES AND RECORDS
JUVENILE DIVISION
CENTURY**

CLERK TO THE BOARD OF
COUNTY COMMISSIONERS
OFFICIAL RECORDS
COUNTY TREASURY
AUDITOR

**ERNIE LEE MAGAHA, CLERK OF THE CIRCUIT COURT
Tax Certificate Redeemed From Sale
Account: 014569000 Certificate Number: 000600 of 2009**

**Payor: EDMUND C WOOD 10002 CHEMSTRAND RD PENSACOLA, FL 32514 Date
07/18/2011**

Clerk's Check #	42144465360	Clerk's Total	\$425.10
Tax Collector Check #	1	Tax Collector's Total	\$4,478.17
		Postage	\$12.00
		Researcher Copies	\$5.00
		Total Received	\$4,920.27

ERNIE LEE MAGAHA
Clerk of the Circuit Court

Received By: _____
Deputy Clerk

Escambia County Government Complex • 221 Palafox Place Ste 110 • PENSACOLA, FLORIDA 32502
(850) 595-3793 • FAX (850) 595-4827 • <http://www.clerk.co.escambia.fl.us>

ERNIE LEE MAGAHA
 CLERK OF THE CIRCUIT COURT
 ARCHIVES AND RECORDS
 CHILDSUPPORT
 CIRCUIT CIVIL
 CIRCUIT CRIMINAL
 COUNTY CIVIL
 COUNTY CRIMINAL
 DOMESTIC RELATIONS
 FAMILY LAW
 JURY ASSEMBLY
 JUVENILE
 MENTAL HEALTH
 MIS
 OPERATIONAL SERVICES
 PROBATE
 TRAFFIC



BRANCH OFFICES
ARCHIVES AND RECORDS
JUVENILE DIVISION
CENTURY

CLERK TO THE BOARD OF
 COUNTY COMMISSIONERS
 OFFICIAL RECORDS
 COUNTY TREASURY
 AUDITOR

COUNTY OF ESCAMBIA
OFFICE OF THE
CLERK OF THE CIRCUIT COURT

Case # 2009 TD 000600
Redeemed Date 07/18/2011

Name EDMUND C WOOD 10002 CHEMSTRAND RD PENSACOLA, FL 32514

<input type="checkbox"/> Clerk's Total = TAXDEED	\$425.10
<input type="checkbox"/> Due Tax Collector = TAXDEED	\$4,478.17
<input type="checkbox"/> Postage = TD2	\$12.00
<input type="checkbox"/> ResearcherCopies = TD6	\$5.00

Apply Docket Codes

• For Office Use Only

Date	Docket	Desc	Amount Owed	Amount Due	Payee Name
06/01/2009	TD1	TAX DEED APPLICATION Receipt: 1281585 Date: 05/03/2011	60.00	0.00	
06/01/2009	TAXDEED	TAX DEED CERTIFICATES Receipt: 1281585 Date: 05/03/2011	330.00	0.00	
05/04/2011	TD83	TAX COLLECTOR CERTIFICATION nlk	0.00	0.00	
05/27/2011	TD82	O & E REPORT nlk	0.00	0.00	

Rcd	Docket Application	Owed	Paid	Dismissed	Due
1	Service Charge	\$60.00	\$60.00	\$0.00	\$0.00
2	Holding	\$330.00	\$330.00	\$0.00	\$0.00
	TOTAL	\$390.00	\$390.00	\$0.00	\$0.00

**Ernie Lee Magaha,
Clerk of the Circuit Court of Escambia County Florida**

Receipt Type **Case** Outstanding Amount **0.00**
Receipt Number **1308662** Receipt Date **07/18/2011**

Case Number **2009 TD 000600**

Description **DICK N & BETTY N RILEY TRUSTEES OF THE RILEY LIVIN VS**

Action **TAX DEED REDEMPTION**

Judge

Received From **EDMUND C WOOD**

On Behalf Of **DICK N & BETTY N RILEY TRUSTEES OF THE
RILEY LIVIN**

Total Received	4,920.27
Net Received	4,920.27
Change	0.00

Receipt Payments	Amount	Reference Description
Check	4,920.27	42144465360

Receipt Applications	Amount
Holding	4,903.27
Service Charge	17.00

Deputy Clerk: **mavila** Transaction Date **07/18/2011 16:14:35**

Comments