

### Notice to Tax Collector of Application for Tax Deed

**TO: Tax Collector of Escambia County**

In accordance with Florida Statutes, I,

**WACHOVIA AS CUST/TTEE FOR PLYMOUTH PARK  
TAX SERVIC  
PO BOX 2288  
MORRISTOWN, New Jersey, 07962-2288**

holder of the following tax sale certificate hereby surrender same to the Tax Collector and make tax deed application thereon:

<b>Certificate No.</b>	<b>Parcel ID Number</b>	<b>Date</b>	<b>Legal Description</b>
81	01-0467-000	06/01/2009	07-1S2-920 LT 14 BLK 6 TIPPIN S/D PB 3 P 39 OR 1187 P 26 OR 2260 P 360 OR 5698 P 1705

**2010 TAX ROLL**

JACKSON BEATRICE N  
3526 RAINES ST  
PENSACOLA, Florida 32514

I agree to pay all delinquent taxes, redeem all outstanding certificates not in my possession, pay any omitted taxes, and pay current taxes, if due, covering the land, and pay any interest earned (a) on tax certificates not in my possession, (b) on omitted taxes or (c) on delinquent taxes. I also agree to pay all Tax Collector's fees, ownership and encumbrance reports costs, Clerk of the Court costs, charges and fees and Sheriff's costs, if applicable. Attached is the above-mentioned tax sale certificate on which this application is based and all other certificates of the same legal description which are in my possession.

MistyPlym (Misty Busteed)  
Applicant's Signature

04/19/2011  
Date

**TAX COLLECTOR'S CERTIFICATION**

**Application  
Date / Number  
Apr 19, 2011 / 110313**

This is to certify that the holder listed below of Tax Sale Certificate Number **2009 / 81** , issued the **1st day of June, 2009**, and which encumbers the following described property located in the County of Escambia, State of Florida to wit: **Parcel ID Number: 01-0467-000**

**Certificate Holder:**  
WACHOVIA AS CUST/TTEE FOR PLYMOUTH PARK TAX  
SERVIC  
PO BOX 2288  
MORRISTOWN, NEW JERSEY 07962-2288

**Property Owner:**  
JACKSON BEATRICE N  
3526 RAINES ST  
PENSACOLA, FLORIDA 32514

**Legal Description:** 07-1S2-920  
LT 14 BLK 6 TIPPIN S/D PB 3 P 39 OR 1187 P 26 OR 2260 P 360 OR 5698 P 1705

has surrendered same in my office and made written application for tax deed in accordance with Florida Statutes. I certify that the following tax certificates, interest, ownership and encumbrance report fee, and Tax Collector's fees have been paid:

**CERTIFICATES OWNED BY APPLICANT AND FILED IN CONNECTION WITH THIS TAX DEED APPLICATION:**

Cert. Year	Certificate Number	Date of Sale	Face Amt	T/C Fee	Interest	Total
2009	81	06/01/09	\$583.98	\$0.00	\$195.88	\$779.86

**CERTIFICATES REDEEMED BY APPLICANT OR INCLUDED (COUNTY) IN CONNECTION WITH THIS APPLICATION:**

Cert. Year	Certificate Number	Date of Sale	Face Amt	T/C Fee	Interest	Total
2010	76	06/01/10	\$590.04	\$6.25	\$29.50	\$625.79

1. Total of all Certificates in Applicant's Possession and Cost of the Certificates Redeemed by Applicant or Included (County)
2. Total of Delinquent Taxes Paid by Tax Deed Application
3. Total of Current Taxes Paid by Tax Deed Applicant (2010)
4. Ownership and Encumbrance Report Fee
5. Tax Deed Application Fee
6. Total Certified by Tax Collector to Clerk of Court
7. Clerk of Court Statutory Fee
8. Clerk of Court Certified Mail Charge
9. Clerk of Court Advertising Charge
10. Sheriff's Fee
11. \_\_\_\_\_
12. Total of Lines 6 thru 11
13. Interest Computed by Clerk of Court Per Florida Statutes.....( %)
14. One-Half of the assessed value of homestead property. If applicable pursuant to section 197.502, F.S.
15. Statutory (Opening) Bid; Total of Lines 12 thru 14
16. Redemption Fee
17. Total Amount to Redeem

\$1,405.65
\$0.00
\$556.25
\$150.00
\$75.00
\$2,186.90
\$2,186.90
\$6.25

\*Done this 19th day of April, 2011

TAX COLLECTOR, ESCAMBIA COUNTY, FLORIDA

By *Donna Makuron*

Date of Sale: *September 6, 2011*

\* This certification must be surrendered to the Clerk of the Circuit Court no later than ten days after this date.

**ERNIE LEE MAGAHA**  
CLERK OF THE CIRCUIT COURT



BRANCH OFFICES  
ARCHIVES AND RECORDS  
JUVENILE DIVISION

CENTURY

ARCHIVES AND RECORDS  
CHILD SUPPORT  
CIRCUIT CIVIL  
CIRCUIT CRIMINAL  
COUNTY CIVIL  
COUNTY CRIMINAL  
DOMESTIC RELATIONS  
FAMILY LAW  
JURY ASSEMBLY  
JUVENILE  
MENTAL HEALTH  
MIS  
OPERATIONAL SERVICES  
PROBATE  
TRAFFIC

**COUNTY OF ESCAMBIA  
OFFICE OF THE  
CLERK OF THE CIRCUIT COURT**

CLERK TO THE BOARD OF  
COUNTY COMMISSIONERS

OFFICIAL RECORDS  
COUNTY TREASURY  
AUDITOR

## IMAGING COVER PAGE

This cover page is not a part of the original documents but is necessary to avoid obscuring any information on the original documents

---

Case: 2009 TD 000081



00034311116

Dkt: TD83 Pg#:

---

3

**Original Documents Follow**

IN THE COUNTY COURT IN THE FIRST JUDICIAL CIRCUIT  
IN AND FOR ESCAMBIA COUNTY, FLORIDA

ERNIE LEE MAGAHA  
CLERK OF CIRCUIT COURT  
JUNE 29 2010  
COUNTY CIVIL DIVISION

CASE NUMBER: 2009-SC-005414 DIV:

TARGET NATIONAL BANK / TARGET VISA,  
a corporation,  
Plaintiff,

vs.

BEATRICE JACKSON,  
Defendant.

FINAL JUDGMENT

The Defendant appeared at the Pre-Trial Conference and admitted to liability and damages as set forth in the  
Complaint, and the Court finding that Plaintiff is entitled to a Final Judgment, it is:

ADJUDGED that the Plaintiff, TARGET NATIONAL BANK / TARGET VISA, recover from the  
Defendant, BEATRICE JACKSON, the principal sum of \$3,304.35, together with \$345.00 for costs of this suit, that  
shall bear interest at the rate of six percent (6%) per year, for which let execution issue.

~~IT IS HEREBY ORDERED AND ADJUDGED that the Defendant shall complete Florida Small Claims  
Rules Form 1.1 (Fact Information Sheet) and return it to the Plaintiff's attorney within 14 days of this  
Final Judgment. The Plaintiff's attorney shall file a copy of this Final Judgment and the  
Fact Information Sheet with the Clerk of the Circuit Court and County Court of Escambia County, Florida. If an appeal is filed,  
jurisdiction of this case is retained in order for the court to accept the proper Escambia County Complete Form  
7-242 and return it to the Plaintiff's attorney.~~

DONE AND ORDERED at Pensacola, Escambia County, Florida this 29th day of  
JUNE, 2010.

  
County Court Judge

"CERTIFIED TO BE A TRUE COPY  
OF THE ORIGINAL ON FILE IN THIS OFFICE  
WITNESS MY HAND AND OFFICIAL SEAL  
ERNIE LEE MAGAHA, CLERK  
CIRCUIT COURT AND COUNTY COURT  
ESCAMBIA COUNTY, FLORIDA"



Copies to:  
Nicole Dawn Young  
Attorney for Plaintiff  
Rubin & Debski, P.A.  
P.O. Box 47718  
Jacksonville, FL 32247

BY: W.D. Weddington D.C.

BEATRICE JACKSON  
Defendant  
3526 RAINES ST  
PENSACOLA FL 32514-6334  
SSN: XXXXXXXXXX

Plaintiff's Address (F.S. 55.10):  
TARGET NATIONAL BANK / TARGET VISA  
3701 Wayzata Blvd.  
Minneapolis, MN 55416

IN THE COUNTY COURT IN AND FOR  
ESCAMBIA COUNTY, FLORIDA

CASE NO: 2009-SC-2609

NORTH STAR CAPITAL ACQUISITION, LLC  
AS ASSIGNEE OF WELLS FARGO

Plaintiff

FINAL JUDGMENT

vs.

BEATRICE JACKSON

Defendant(s)

THIS CAUSE having come to be heard before this Honorable Court for a Pre-Trial Conference  
on 07/15/2009 and the Court having heard argument of counsel and being otherwise fully advised in the  
premises, finds as follows:

IT IS HEREBY ORDERED AND ADJUDGED THAT:

Plaintiff whose address is 101 Gateway Center Parkway Richmond, VA 23235, shall recover  
from Defendant(s) BEATRICE JACKSON the principal sum of \$3,775.01, court costs in the amount of  
\$330.00, interest in the amount \$308.62. that shall bear interest at the rate of 8% per annum for all of the  
above let execution issue.

IT IS FURTHER ORDERED AND ADJUDGED THAT:

The Defendant(s) shall complete the Florida Small Claims Rules Form 7.343 (Fact Information  
Sheet) and return it to the Plaintiff's attorney, within 45 days from the date of this Final Judgment, unless  
the Final Judgment is satisfied or a motion for new trial or notice of appeal is filed.

Jurisdiction of this case is retained to enter further orders that are proper to compel the  
Defendant(s) to complete form 7.343 and return it to the Plaintiff's attorney. The Fact Information Sheet  
need not be recorded in the Public Records.

DONE AND ORDERED in Escambia County, Florida on this the 29 day of Sept  
2009.

  
COUNTY COURT JUDGE

Copies furnished to:  
Hayt, Hayt & Landau, P.L.  
7765 SW 87 Ave, Suite 101  
Miami, FL 33173

BEATRICE JACKSON  
3526 RAINES ST  
PENSACOLA, FL 32514-6334  
Our File #: 110379 

ERNE LEE MAGAHA  
CLERK OF CIRCUIT COURT  
ESCAMBIA COUNTY, FL  
2009 SEP 30 A 9:22  
COUNTY CIVIL DIVISION  
FILED & RECORDED

CERTIFIED TO BE A TRUE COPY OF THE  
ORIGINAL ON FILE IN THIS OFFICE  
WITNESS MY HAND AND OFFICIAL SEAL  
ERNE LEE MAGAHA  
CLERK & COMPTROLLER  
ESCAMBIA COUNTY, FLORIDA

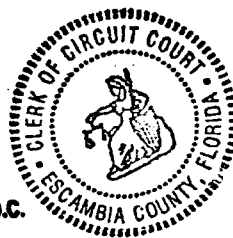

BY:  D.C.

Case: 2009 SC 002609

  
00063389014

Dkt: CC1036 Pg#: 1

After recording, please return to:  
CITIFINANCIAL EQUITY  
SERVICES, INC.  
5007 N DAVIS HWY SUITE 17  
PENSACOLA FL 32503

This instrument was prepared by:  
CITIFINANCIAL EQUITY  
SERVICES, INC.  
5007 N DAVIS HWY SUITE 17  
PENSACOLA FL 32503

## MORTGAGE

THIS MORTGAGE is made this 9th day of August, 2005, between the Mortgagor,  
BEATRICE NELLIE JACKSON A SINGLE PERSON

(herein "Borrower"),

and the Mortgagee, CITIFINANCIAL EQUITY SERVICES, INC.,  
a corporation organized and existing under the laws of Oklahoma,  
whose address is 5007 N DAVIS HWY SUITE 17 PENSACOLA FL 32503  
(herein "Lender").

WHEREAS, Borrower is indebted to Lender in the principal sum of U.S. \$ 78,702.31,  
which indebtedness is evidenced by Borrower's note dated 08/09/2005 and extensions and renewals  
thereof (herein "Note"), providing for monthly installments of principal and interest, with the balance of  
indebtedness, if not sooner paid, due and payable on 08/15/2025 ;

TO SECURE to Lender the repayment of the indebtedness evidenced by the Note, with the interest thereon;  
the payment of all other sums, with interest thereon, advanced in accordance herewith to protect the security of  
this Mortgage; and the performance of the covenants and agreements of Borrower herein contained, Borrower  
does hereby mortgage, grant and convey to Lender the following described property located in the County of  
ESCAMBIA, State of Florida:

ALL THAT CERTAIN PARCEL OF LAND IN ESCAMBIA COUNTY, STATE OF FL, AS  
MORE FULLY DESCRIBED IN OR BOOK 2260 PAGE 360 ID#0718-29-2000-014-006,  
BEING KNOWN AND DESIGNATED AS LOT 14, BLOCK 6, TIPPIN SUBDIVISION,  
FILED IN PLAT BOOK 3 AT PAGE 39.

BEING THE SAME PROPERTY CONVEYED BY FEE SIMPLE DEED FROM JIMMY LEE  
JACKSON AND BEATRICE NELLIE JACKSON TO BEATRICE NELLIE JACKSON AND  
AMANDA LEA JACKSON, DATED 07/28/1986 RECORDED ON 08/08/1986 IN OR  
BOOK 2260, PAGE 360 IN ESCAMBIA COUNTY RECORDS, STATE OF FL.

TOGETHER with all the improvements now or hereafter erected on the property, and all easements, rights,  
appurtenances and rents, all of which shall be deemed to be and remain a part of the property covered by this  
Mortgage; and all of the foregoing, together with said property (or the leasehold estate if this Mortgage is on a  
leasehold) are hereinafter referred to as the "Property."

Borrower covenants that Borrower is lawfully seised of the estate hereby conveyed and has the right to  
mortgage, grant and convey the Property, and that the Property is unencumbered, except for encumbrances of  
record. Borrower covenants that Borrower warrants and will defend generally the title to the Property against all  
claims and demands, subject to encumbrances of record.

### QUIT CLAIM DEED

STATE OF FLORIDA  
COUNTY OF ESCAMBIA

KNOW ALL MEN BY THESE PRESENTS, That AMANDA LEA LEGEAR Formerly Amanda Lea Jackson, for and in consideration of the sum of TEN DOLLARS(\$10.00), and other valuable considerations, receipt whereof is hereby acknowledged, to remise, release, and quit claim unto BEATRICE NELLIE JACKSON, her heirs, executors, administrators and assigns forever, the following described property, situated in Escambia County, State of Florida to wit:

Lot numbered Fourteen(14) in Block numbered Six(6) in the subdivision known as Tippin Subdivision in part of the South Half (S½) of Section 7, Township 1 South, Range 29 West, as shown on plat of said subdivision appearing of record at Page 39 of Plat Book 3 of the records of Escambia County, Florida.

Parcel ID# 07 1S 29 2000 014 006

Together with all and singular the tenements, hereditaments and appurtenances thereto belonging or in any wise appertaining, free from all exemptions and right of homestead.

IN WITNESS WHEREOF, I have hereunto set my hand and seal this 4 day of August, 2005.

Signed, sealed and delivered in our presence

[Signature]  
Beulah B. Robinson  
[Signature]  
Kathy Shon

[Signature]  
AMANDA LEA LEGEAR [Signature]

STATE OF FLORIDA  
COUNTY OF ESCAMBIA

The foregoing instrument was acknowledged before me this 4th day of August 2005, by Amanda Lea Legear, who produced identification of FL Driver's License and did not take an oath.  
Ernie Lee Magaha, Clerk of the Circuit Court

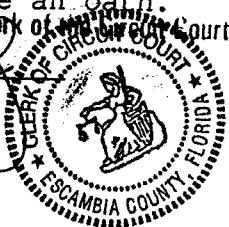
[Signature]  
Notary Public  
Deputy Clerk  

Prepared By:  
Beatrice Nellie Jackson  
3526 Raines St  
Pensacola, FL 32514  
Return To:  
Same Name and Address as Above

# SOUTHERN GUARANTY TITLE COMPANY

4400 BAYOU BLVD., SUITE 13-B, CORDOVA SQUARE

PENSACOLA, FLORIDA 32503

TEL. (850) 478-8121 FAX (850) 476-1437

Email: rcsgr@aol.com

Janet Holley  
Escambia County Tax Collector  
P.O. Box 1312  
Pensacola, FL 32596

CERTIFICATION: TITLE SEARCH FOR TDA

TAX DEED SALE DATE: September 6, 2011

TAX ACCOUNT NO.: 01-0467-000

CERTIFICATE NO.: 2009-81

In compliance with Section 197.256, Florida Statutes, the following is a list of names and addresses of those persons, firms and/or agencies having legal interest in or claim against the above described property. The above referenced tax sale certificate is being submitted as proper notification of tax deed sale.

YES NO

- Notify City of Pensacola, P.O. Box 12910, 32596
- Notify Escambia County, 190 Governmental Center, 32501
- Homestead for 2010<sup>or</sup> tax year.

Beatrice Nelli Jackson  
Jimmy Lee Jackson (husband)  
3526 Raines St.  
Pensacola, FL 32514

North Star Capital Acquisition, LLC  
as Assignee of Wells Fargo  
101 Gateway Center Pkwy.  
Richmond, VA 23235

Citifinancial Equity Services, Inc.  
5007 N. Davis Hwy Ste 17  
Pensacola, FL 32503

Target National Bank/Target VISA  
3701 Wayzata Blvd.  
Minneapolis, MN 55416

Certified and delivered to Escambia County Tax Collector,  
this 12th day of May, 2011.

SOUTHERN GUARANTY TITLE COMPANY

  
by: Richard S. Combs, President

NOTE: The above listed addresses are based upon current information available, but said addresses are not guaranteed to be true or correct.



**OWNERSHIP AND ENCUMBRANCE REPORT  
CONTINUATION PAGE**

File No.: 8771

May 5, 2011

**UNSATISFIED MORTGAGES, LIENS AND JUDGMENTS AFFECTING THE LAND COVERED BY THIS REPORT THAT APPEAR OF RECORD:**

1. That certain mortgage executed by Beatrice Nellie Jackson, a married woman in favor of Citifinancial Equity Services, Inc. dated 08/09/2005 and recorded 08/09/2005 in Official Records Book 5703, page 1010 of the public records of Escambia County, Florida, in the original amount of \$78,702.31.
2. Judgment filed by North Star Capital Acquisition, LLC as assignee of Wells Fargo recorded in O.R. Book 6531, page 224.
3. Judgment filed by Target National Bank/Target Visa recorded in O.R. Book 6667, page 925.
4. Taxes for the year 2008-2009 delinquent. The assessed value is \$59,656.00. Tax ID 01-0467-000.

**PLEASE NOTE THE FOLLOWING:**

- A. Taxes and assessments due now or in subsequent years.
- B. Subject to Easements, Restrictions and Covenants of record.
- C. Oil, gas, mineral or any other subsurface rights of any kind or nature.
- D. Encroachments, overlaps, boundary line disputes, and any other matters which would be disclosed by an accurate survey and inspection of the premises.

**OWNERSHIP AND ENCUMBRANCE REPORT  
LEGAL DESCRIPTION**

File No.: 8771

May 5, 2011

Lot 14, Block 6, Tippin Subdivision, as per plat thereof, recorded in Plat Book 3, Page 39, of the Public Records of Escambia County, Florida

# Southern Guaranty Title Company

4400 Bayou Boulevard, Suite 13B

Pensacola, Florida 32503

Telephone: 850-478-8121

Facsimile: 850-476-1437

## OWNERSHIP AND ENCUMBRANCE REPORT

File No.: 8771

May 5, 2011

Escambia County Tax Collector  
P.O. Box 1312  
Pensacola, Florida 32569

Pursuant to your request, the Company has caused a search to be made of the Public Records of Escambia County, Florida, solely as revealed by records maintained from 05-05-91, through 05-05-11, and said search reveals the following:

1. THE GRANTEE(S) OF THE LAST DEED(S) OF RECORD IS:

Beatrice Nellie Jackson, a married woman

2. The land covered by this Report is:

LEGAL DESCRIPTION IS ATTACHED HERETO AND MADE A PART HEREOF

3. The following unsatisfied mortgages, liens and judgments affecting the land covered by this Report appear of record:

SEE CONTINUATION PAGE ATTACHED HERETO AND MADE A PART HEREOF

4. Taxes:

SEE CONTINUATION PAGE ATTACHED HERETO AND MADE A PART HEREOF

The foregoing report is prepared and furnished for information only, is not intended to constitute or imply any opinion, warranty, guaranty, insurance, or similar assurance as to the status of title, and no determination has been made of the authenticity of any instrument described or referred to herein. The name search for the purposes of determining applicable judgments and liens is limited to the apparent record owner(s) shown herein, No attempt has been made to determine whether the land is subject to liens or assessments which are not shown as existing liens by the public records. The Company's liability hereunder shall not exceed the cost of this Report, or \$1,000.00 whichever is less.

THIS REPORT SHALL NOT BE USED FOR THE ISSUANCE OF TITLE INSURANCE.

Southern Guaranty Title Company

By: 

May 5, 2011

**ERNIE LEE MAGAHA**  
CLERK OF THE CIRCUIT COURT



BRANCH OFFICES  
ARCHIVES AND RECORDS  
JUVENILE DIVISION

CENTURY

ARCHIVES AND RECORDS  
CHILD SUPPORT  
CIRCUIT CIVIL  
CIRCUIT CRIMINAL  
COUNTY CIVIL  
COUNTY CRIMINAL  
DOMESTIC RELATIONS  
FAMILY LAW  
JURY ASSEMBLY  
JUVENILE  
MENTAL HEALTH  
MIS  
OPERATIONAL SERVICES  
PROBATE  
TRAFFIC

**COUNTY OF ESCAMBIA  
OFFICE OF THE  
CLERK OF THE CIRCUIT COURT**

CLERK TO THE BOARD OF  
COUNTY COMMISSIONERS

OFFICIAL RECORDS  
COUNTY TREASURY  
AUDITOR

## IMAGING COVER PAGE

This cover page is not a part of the original documents but is necessary to avoid obscuring any information on the original documents

---

Case: 2009 TD 000081



00068593356

Dkt: TD82 Pg#:

---

9

**Original Documents Follow**

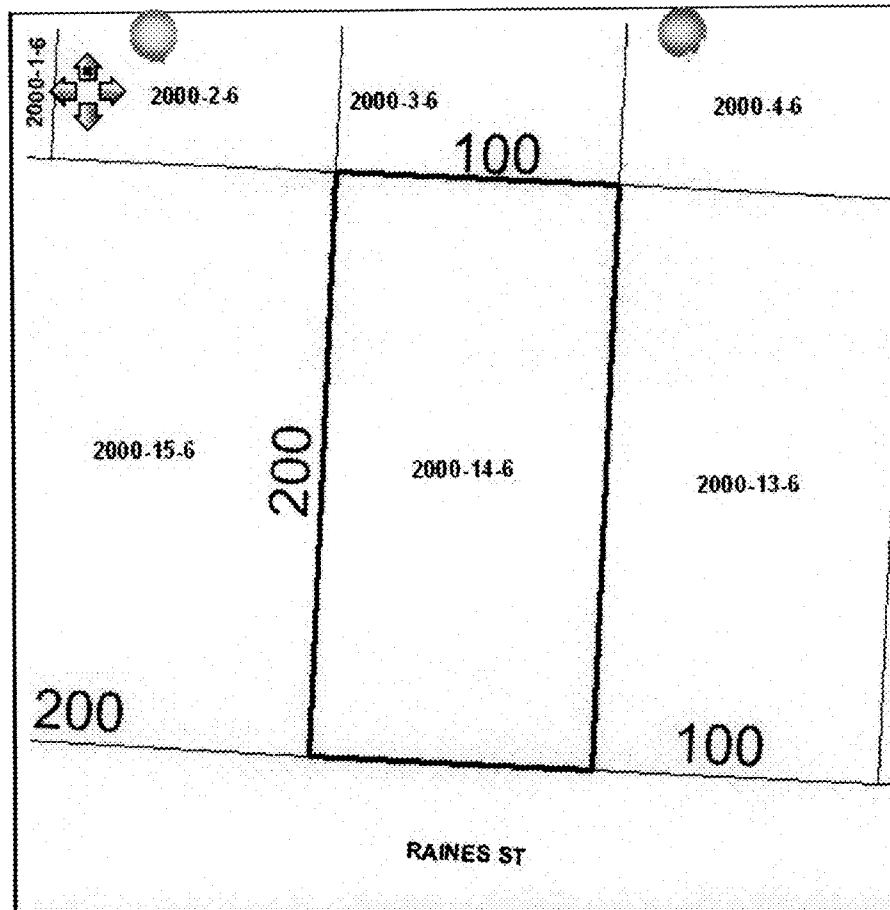

**Buildings**

Building 1 - Address: 3526 RAINES ST, Year Built: 1963, Effective Year: 1975

**Structural Elements**

- FOUNDATION-SLAB ON GRADE**
- EXTERIOR WALL-SIDING-SHT.AVG.**
- NO. PLUMBING FIXTURES-3.00**
- DWELLING UNITS-1.00**
- ROOF FRAMING-GABLE-HI PITCH**
- ROOF COVER-DIMEN/ARCH SHNG**
- INTERIOR WALL-DRYWALL-PLASTER**
- FLOOR COVER-CARPET**
- NO. STORIES-1.00**
- DECOR/MILLWORK-AVERAGE**
- HEAT/AIR-CENTRAL H/AC**
- STRUCTURAL FRAME-WOOD FRAME**

**Areas - 2198 Total SF**

- BASE AREA - 1289**
- GARAGE UNFIN - 405**
- OPEN PORCH FIN - 130**
- OPEN PORCH UNF - 286**
- UTILITY FIN - 88**

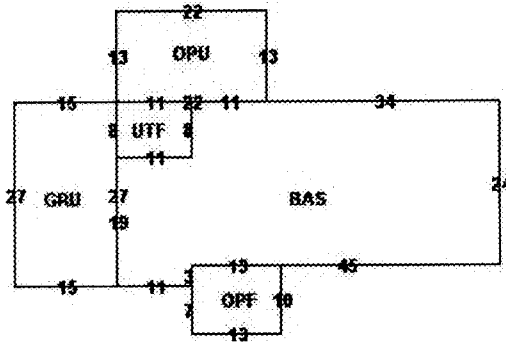

**Images**



02/06/02



# Chris Jones

## Escambia County Property Appraiser

Real Estate Search | Tangible Property Search | Amendment 1 Calculations

[Back](#)

**Navigate Mode**
 **Account**  
 **Reference**

[Print Friendly Version](#)

General Information	
<b>Reference:</b>	071S292000014006
<b>Account:</b>	010467000
<b>Owners:</b>	JACKSON BEATRICE N
<b>Mail:</b>	3526 RAINES ST PENSACOLA, FL 32514
<b>Situs:</b>	3526 RAINES ST 32514
<b>Use Code:</b>	SINGLE FAMILY RESID
<b>Taxing Authority:</b>	COUNTY MSTU
<b>Tax Inquiry:</b>	<a href="#">Open Tax Inquiry Window</a>
Tax Inquiry link courtesy of Janet Holley, Escambia County Tax Collector	

2010 Certified Roll Assessment	
<b>Improvements:</b>	\$54,665
<b>Land:</b>	\$24,700
<b>Total:</b>	\$79,365
<b>Save Our Homes:</b>	\$59,656
<a href="#">Disclaimer</a>	

[Amendment 1 Calculations](#)

Sales Data					
Sale Date	Book	Page	Value	Type	Official Records (New Window)
08/2005	5698	1705	\$100	QC	<a href="#">View Instr</a>
07/1986	2260	360	\$100	WD	<a href="#">View Instr</a>
01/1978	1187	26	\$22,000	WD	<a href="#">View Instr</a>
01/1967	348	853	\$9,400	WD	<a href="#">View Instr</a>
Official Records Inquiry courtesy of Ernie Lee Magaha, Escambia County Clerk of the Court					

2010 Certified Roll Exemptions	
HOMESTEAD EXEMPTION	
<a href="#">Legal Description</a>	
LT 14 BLK 6 TIPPIN S/D PB 3 P 39 OR 1187 P 26 OR 2260 P 360...	
<a href="#">Extra Features</a>	
FRAME BUILDING FRAME SHED	

Parcel Information [Print Map](#) [Get Map Image](#) [Launch Interactive Map](#)

<b>Section Map Id:</b> 07-1S-29-2
<b>Approx. Acreage:</b> 0.4600
<b>Zoned:</b> R-4

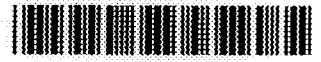

**Print Date:**  
5/4/2011 2:53:02 PM

ERNIE LEE MAGAHA  
Clerk of the Circuit Court  
Escambia County, FL  
P.O. Box 333  
Pensacola, FL 32591  
850-595-3930

Transaction #: 857175  
Receipt #: 201123850  
Cashier Date: 5/4/2011 2:53:00 PM (MAVILA)

Customer Information	Transaction Information	Payment Summary
(TXD) TAX DEED DIVISION CLERK OF THE CIRCUIT COURT 221 PALAFOX PLACE Pensacola, FL 32502	Date Received: 05/04/2011 Source Code: Over the Counter Q Code: Return Code: Government Trans Type: Recording Agent Ref Num:	Total Fees \$390.00 Total Payments \$390.00

1 Payments	
CLERK	\$390.00

0 Recorded Items	
------------------	--

0 Search Items	
----------------	--

1 Miscellaneous Items		
(MISC FEE) MISCELLANEOUS FEES 2009 TD 00081		
TAXCT	1	\$60.00
TAXCR	330	\$330.00

**Ernie Lee Magaha,  
Clerk of the Circuit Court of Escambia County Florida**

Receipt Type **Case** Outstanding Amount **0.00**  
Receipt Number **1282047** Receipt Date **05/04/2011**

Case Number **2009 TD 000081**  
Description **WACHOVIA AS CUST/TTEE FOR PLYMOUTH PARK TAX SERVIC VS**

Action **TAX DEED APPLICATION**

Judge

Received From **PLYMOUTH PARK TAX SERVICES**

On Behalf Of **WACHOVIA AS CUST/TTEE FOR PLYMOUTH PARK  
TAX SERVIC**

Total Received	390.00
Net Received	390.00
Change	0.00

Receipt Payments	Amount	Reference Description
Cash	390.00	ONCORE TRANS#857175

Receipt Applications	Amount
Holding	330.00
Service Charge	60.00

Deputy Clerk: **mavila** Transaction Date **05/04/2011 14:53:44**

Comments



**ERNIE LEE MAGAHA**  
 CLERK OF THE CIRCUIT COURT  
 ARCHIVES AND RECORDS  
 CHILDSUPPORT  
 CIRCUIT CIVIL  
 CIRCUIT CRIMINAL  
 COUNTY CIVIL  
 COUNTY CRIMINAL  
 DOMESTIC RELATIONS  
 FAMILY LAW  
 JURY ASSEMBLY  
 JUVENILE  
 MENTAL HEALTH  
 MIS  
 OPERATIONAL SERVICES  
 PROBATE  
 TRAFFIC



**BRANCH OFFICES**  
**ARCHIVES AND RECORDS**  
**JUVENILE DIVISION**  
**CENTURY**

CLERK TO THE BOARD OF  
 COUNTY COMMISSIONERS  
 OFFICIAL RECORDS  
 COUNTY TREASURY  
 AUDITOR

**COUNTY OF ESCAMBIA**  
**OFFICE OF THE**  
**CLERK OF THE CIRCUIT COURT**

**Case # 2009 TD 000081**

**Redeemed Date 05/05/2011**

**Name BEATRICE N JACKSON 3526 RAINES ST PENSACOLA, FL 32514**

Clerk's Total = TAXDEED	\$419.25
Due Tax Collector = TAXDEED	\$2,357.17
<input type="checkbox"/> Postage = TD2	\$60.00
<input type="checkbox"/> ResearcherCopies = TD6	\$40.00

Apply Docket Codes

• For Office Use Only

Date	Docket	Desc	Amount Owed	Amount Due	Payee Name
06/01/2009	TD1	TAX DEED APPLICATION Receipt: 1282047 Date: 05/04/2011	60.00	0.00	
06/01/2009	TAXDEED	TAX DEED CERTIFICATES Receipt: 1282047 Date: 05/04/2011	330.00	0.00	
05/02/2011	TD83	TAX COLLECTOR CERTIFICATION nlk	0.00	0.00	
05/05/2011	TAXDEED	TAXDEED Due Tax Collector	2,357.17	2,357.17	
05/05/2011	TAXDEED	TAXDEED Clerk's Total	419.25	419.25	

Red	Docket Application	Owed	Paid	Dismissed	Due
1	Service Charge	\$60.00	\$60.00	\$0.00	\$0.00
2	Holding	\$3,106.42	\$330.00	\$0.00	\$2,776.42
	<b>TOTAL</b>	<b>\$3,166.42</b>	<b>\$390.00</b>	<b>\$0.00</b>	<b>\$2,776.42</b>

**ERNIE LEE MAGAHA**  
CLERK OF THE CIRCUIT COURT  
ARCHIVES AND RECORDS  
CHILDSUPPORT  
CIRCUIT CIVIL  
CIRCUIT CRIMINAL  
COUNTY CIVIL  
COUNTY CRIMINAL  
DOMESTIC RELATIONS  
FAMILY LAW  
JURY ASSEMBLY  
JUVENILE  
MENTAL HEALTH  
MIS  
OPERATIONAL SERVICES  
PROBATE  
TRAFFIC



**COUNTY OF ESCAMBIA  
OFFICE OF THE  
CLERK OF THE CIRCUIT COURT**

**BRANCH OFFICES  
ARCHIVES AND RECORDS  
JUVENILE DIVISION  
CENTURY**

CLERK TO THE BOARD OF  
COUNTY COMMISSIONERS  
OFFICIAL RECORDS  
COUNTY TREASURY  
AUDITOR

**ERNIE LEE MAGAHA, CLERK OF THE CIRCUIT COURT**  
**Tax Certificate Redeemed From Sale**  
**Account: 010467000 Certificate Number: 000081 of 2009**

**Payor: BEATRICE N JACKSON 3526 RAINES ST PENSACOLA, FL 32514 Date 05/05/2011**

Clerk's Check #	10000078946	Clerk's Total	\$419.25
Tax Collector Check #	1	Tax Collector's Total	\$2,357.17
		Postage	\$60.00
		Researcher Copies	\$40.00
		Total Received	\$2,876.42

**ERNIE LEE MAGAHA**  
Clerk of the Circuit Court

Received By: \_\_\_\_\_  
Deputy Clerk

Escambia County Government Complex • 221 Palafox Place Ste 110 • PENSACOLA, FLORIDA 32502  
(850) 595-3793 • FAX (850) 595-4827 • <http://www.clerk.co.escambia.fl.us>

Ernie Lee Magaha,  
Clerk of the Circuit Court of Escambia County Florida

Receipt Type Case Outstanding Amount 0.00  
Receipt Number 1282483 Receipt Date 05/05/2011

Case Number 2009 TD 000081

Description WACHOVIA AS CUST/TTEE FOR PLYMOUTH PARK TAX SERVIC VS

Action TAX DEED REDEMPTION

Judge

Received From BEATRICE JACKSON

On Behalf Of WACHOVIA AS CUST/TTEE FOR PLYMOUTH PARK  
TAX SERVIC

Total Received	2,876.42
Net Received	2,876.42
Change	0.00

Receipt Payments	Amount	Reference	Description
Check	2,876.42	010000078946	

Receipt Applications	Amount
Holding	2,876.42

Deputy Clerk: mavila Transaction Date 05/05/2011 12:48:28

Comments



**ERNIE LEE MAGAHA  
CLERK OF THE CIRCUIT COURT  
ESCAMBIA COUNTY, FLORIDA**

**Tax Deed - Redemption Calculator**

**Account: 010467000 Certificate Number: 000081 of 2009**

Redemption  Yes Application Date  Interest Rate

	Final Redemption Payment ESTIMATED	Redemption Overpayment ACTUAL
	Auction Date <input type="text" value="09/06/2011"/>	Redemption Date <input type="text" value="05/05/2011"/>
Months	5	1
Tax Collector	<input type="text" value="\$2,186.90"/>	<input type="text" value="\$2,186.90"/>
Tax Collector Interest	\$164.02	\$32.80
Tax Collector Fee	<input type="text" value="\$6.25"/>	<input type="text" value="\$6.25"/>
<b>Total Tax Collector</b>	<b>\$2,357.17</b>	<b>\$2,225.95</b>
Clerk Fee	<input type="text" value="\$60.00"/>	<input type="text" value="\$60.00"/>
Sheriff Fee	<input type="text" value="\$120.00"/>	<input type="text" value="\$120.00"/>
Legal Advertisement	<input type="text" value="\$210.00"/>	<input type="text" value="\$210.00"/>
App. Fee Interest	\$29.25	\$5.85
<b>Total Clerk</b>	<b>\$419.25</b>	<b>\$395.85</b>
Postage	<input type="text" value="\$60.00"/>	<input type="text" value="\$0.00"/>
Researcher Copies	<input type="text" value="\$40.00"/>	<input type="text" value="\$0.00"/>
<b>Total Redemption Amount</b>	<b>\$2,876.42</b>	<b>\$2,621.80</b>
	Repayment Overpayment Refund Amount	$254.62 + 120 + 210 = 584.62$

Notes

**ERNIE LEE MAGAHA**  
CLERK OF THE COURT & COMPTROLLER  
P.O. BOX 333  
PENSACOLA, FL 32591-0333  
(850) 595-4140  
REGISTRY ACCOUNT

Bank of America  
PENSACOLA, FLORIDA

9000014279

63-27  
631

VOID AFTER 6 MONTHS

PAY

\*FIVE HUNDRED EIGHTY FOUR AND 62/100

BEATRICE N JACKSON

TO THE ORDER OF BEATRICE N JACKSON  
3526 RAINES ST  
PENSACOLA, FL 32514

DATE: 05/10/2011  
AMOUNT: 584.62

*Ernie Lee Magaha*  
ERNIE LEE MAGAHA, CLERK OF THE COURT



⑈9000014279⑈ ⑆063100277⑆ 898033991356⑈

**ERNIE LEE MAGAHA**  
CLERK OF THE COURT & COMPTROLLER

9000014279

Date	Case Number	Description	Amount
05/10/2011	2009 TD 000081	PAYMENT TAX DEEDS	584.62

9000014279

Check: 9000014279 05/10/2011 BEATRICE N JACKSON

Check Amount: 584.62

THE REVERSE SIDE OF THIS DOCUMENT INCLUDES MICROPRINTED ENDORSEMENT LINES AND AN ARTIFICIAL WATERMARK. HOLD AT AN ANGLE TO VIEW.

**ERNIE LEE MAGAHA**  
CLERK OF THE COURT & COMPTROLLER  
P.O. BOX 333  
PENSACOLA, FL 32591-0333  
(850) 595-4140  
REGISTRY ACCOUNT

Bank of America  
PENSACOLA, FLORIDA  
VOID AFTER 6 MONTHS

9000014279

63-27  
631

PAY

\*FIVE HUNDRED EIGHTY FOUR AND 62/100

BEATRICE N JACKSON

TO THE ORDER OF BEATRICE N JACKSON  
3526 RAINES ST  
PENSACOLA, FL 32514

DATE 05/10/2011  
AMOUNT 584.62

*Ernie Lee Magaha*  
ERNIE LEE MAGAHA, CLERK OF THE COURT



⑈9000014279⑈ ⑆063100277⑆ 898033991356⑈

**ERNIE LEE MAGAHA**  
CLERK OF THE COURT & COMPTROLLER

9000014279

Date	Case Number	Description	Amount
05/10/2011	2009 TD 000081	PAYMENT TAX DEEDS	584.62

9000014279

Check: 9000014279 05/10/2011 BEATRICE N JACKSON

Check Amount: 584.62

**ERNIE LEE MAGAHA**  
CLERK OF THE COURT & COMPTROLLER  
P.O. BOX 333  
PENSACOLA, FL 32581-0333  
(850) 595-4140  
REGISTRY ACCOUNT

Bank of America  
PENSACOLA, FLORIDA  
VOID AFTER 6 MONTHS

9000014306

63-27  
631

PAY

\*THREE THOUSAND ONE HUNDRED SIXTY AND 95/100

WACHOVIA AS CUST/TTEE FOR PLYMOUTH PARK  
TAX SERVICE

TO THE  
ORDER  
OF

WACHOVIA AS CUST/TTEE FOR PLYMOUTH PARK TAX  
P O BOX 2289  
MORRISTOWN, NJ 07962

DATE

AMOUNT

05/10/2011

3,160.95

*Ernie Lee Magaha*  
ERNIE LEE MAGAHA, CLERK OF THE COURT



⑈9000014306⑈ ⑆063100277⑆ 898033991356⑈

**ERNIE LEE MAGAHA**  
CLERK OF THE COURT & COMPTROLLER

9000014306

Date	Case Number	Description	Amount
05/10/2011	2009 TD 008637	PAYMENT TAX DEEDS	395.85
05/10/2011	2009 TD 002847	PAYMENT TAX DEEDS	390.00
05/10/2011	2009 TD 007754	PAYMENT TAX DEEDS	395.85
05/10/2011	2009 TD 000330	PAYMENT TAX DEEDS	395.85
05/10/2011	2009 TD 007164	PAYMENT TAX DEEDS	395.85
05/10/2011	2009 TD 011535	PAYMENT TAX DEEDS	395.85
05/10/2011	2009 TD 005173	PAYMENT TAX DEEDS	395.85
05/10/2011	2009 TD 000081	PAYMENT TAX DEEDS	395.85

9000014306

Check: 9000014306 05/10/2011 WACHOVIA AS CUST/TTEE FOR  
PLYMOUTH PARK TAX SERVICE

Check Amount: 3,160.95

THE REVERSE SIDE OF THIS DOCUMENT INCLUDES MICROPRINTED ENDORSEMENT LINES AND ARTIFICIAL WATERMARK - HOLD AT AN ANGLE TO VIEW

ERNIE LEE MAGAHA  
CLERK OF THE COURT & COMPTROLLER  
P.O. BOX 333  
PENSACOLA, FL 32591-0333  
(850) 595-4140  
REGISTRY ACCOUNT

Bank of America  
PENSACOLA, FLORIDA  
VOID AFTER 6 MONTHS

9000014295

63-27  
631

PAY \*EIGHTY TWO THOUSAND FIVE HUNDRED FORTY FIVE AND 16/100

JANET HOLLEY TAX COLLECTOR

TO THE ORDER OF JANET HOLLEY TAX COLLECTOR  
213 PALAFOX PLACE  
PENSACOLA, FL 32502

DATE 05/10/2011 AMOUNT 82,545.16

*Ernie Lee Magaha*  
ERNIE LEE MAGAHA, CLERK OF THE COURT



⑈9000014295⑈ ⑆063100277⑆ 898033991356⑈

ERNIE LEE MAGAHA  
CLERK OF THE COURT & COMPTROLLER

9000014295

Date	Case Number	Description	Amount
05/10/2011	2008 TD 001089	PAYMENT TAX DEEDS	1,951.05
05/10/2011	2008 TD 002332	PAYMENT TAX DEEDS	464.01
05/10/2011	2009 TD 008637	PAYMENT TAX DEEDS	9,256.58
05/10/2011	2009 TD 001286	PAYMENT TAX DEEDS	1,257.57
05/10/2011	2009 TD 005173	PAYMENT TAX DEEDS	11,496.51
05/10/2011	2009 TD 000330	PAYMENT TAX DEEDS	11,469.02
05/10/2011	2009 TD 007754	PAYMENT TAX DEEDS	19,651.53
05/10/2011	2009 TD 001307	PAYMENT TAX DEEDS	5,057.74
05/10/2011	2009 TD 001412	PAYMENT TAX DEEDS	387.17
05/10/2011	2009 TD 001654	PAYMENT TAX DEEDS	1,147.77

There are additional check details for this check that total:

21,105.04  
9000014295

Check: 9000014295 05/10/2011 JANET HOLLEY TAX COLLECTOR

Check Amount: 82,545.16

2006 TD 05661 936.87  
 2008 TD 03017 961.68  
 2009 TD 07164 5,095.54  
 2009 TD 02847 7,215.53  
 2009 TD 011535 2,857.10  
 2008 TD 02185 1,812.37  
 2009 TD 10081 2,225.95

*Janet M.*  
5-10-11