

Print Date:
4/28/2010 8:40:18 AM

ERNIE LEE MAGAHA
Clerk of the Circuit Court
Escambia County, FL
P.O. Box 333
Pensacola, FL 32591
850-595-3930

Transaction #: 791353
Receipt #: 201018704
Cashier Date: 4/28/2010 8:40:18 AM (MAVILA)

Customer Information	Transaction Information	Payment Summary
(TXD) TAX DEED DIVISION CLERK OF THE CIRCUIT COURT 221 PALAFOX PLACE Pensacola, FL 32502	Date Received: 04/28/2010 Source Code: Over the Counter Q Code: Return Code: Government Trans Type: Recording Agent Ref Num:	Total Fees \$12090.00 Total Payments \$12090.00

1 Payments	
 CLERK	\$12090.00

0 Recorded Items	
------------------	--

0 Search Items	
----------------	--

1 Miscellaneous Items		
 (MISCFEE) MISCELLANEOUS FEES 09/13/2010 TAX DEED SALE(31 CASES)		
TAXCT	31	\$1860.00
TAXCR	10230	\$10230.00



Chris Jones

Escambia County Property Appraiser

Real Estate Search | Tangible Property Search | Amendment 1 Calculations

Back

Navigate Mode
 Account
 Reference

Printer Friendly Version

General Information	
Reference:	282S262150007010
Account:	170836500
Owners:	HAZEN MELANIE J
Mail:	1895 DANBURY EAST OKEMOS, MI 48864
Situs:	807 ARIOLA DR
Use Code:	SINGLE FAMILY RESID
Taxing Authority:	PENSACOLA BEACH
Tax Inquiry:	Open Tax Inquiry Window
Tax Inquiry link courtesy of Janet Holley, Escambia County Tax Collector	

2009 Certified Roll Assessment	
Improvements:	\$257,140
Land:	\$256,500
Total:	\$513,640
<i>Save Our Homes:</i>	\$0
Disclaimer	
Amendment 1 Calculations	

Sales Data					
Sale Date	Book	Page	Value	Type	Official Records (New Window)
10/2005	5789	1456	\$100	LI	View Instr
04/1991	3000	438	\$100	LI	View Instr
04/1991	2998	772	\$95,000	LI	View Instr
Official Records Inquiry courtesy of Ernie Lee Magaha, Escambia County Clerk of the Court					

2009 Certified Roll Exemptions	
LAND (PENSACOLA BEACH)	
Legal Description	LTS 7 & 8 BLK 10 VILLA SEGUNDA PB 3 P 80 OR 2998 P 772 OR 5789 P 1456...
Extra Features	None

Parcel Information [Restore Map](#) [Launch Interactive Map](#)

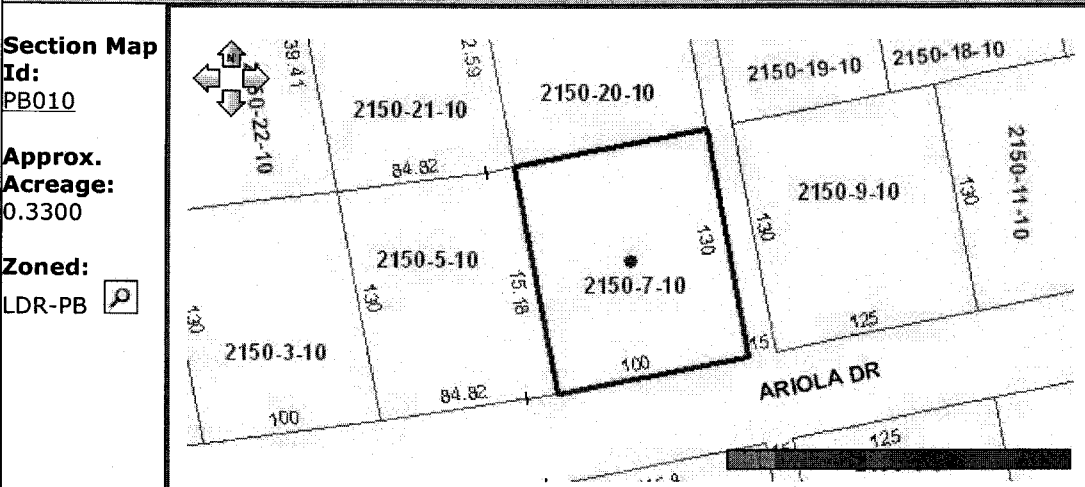

Buildings	
Building 1 - Address: 807 ARIOLA DR, Year Built: 1998, Effective Year: 1998	
Structural Elements	
FOUNDATION-PILINGS	
EXTERIOR WALL-STUCCO	
NO. PLUMBING FIXTURES-11.00	
DWELLING UNITS-1.00	

ROOF FRAMING-DIMEN ROOF DESGN
ROOF COVER-DIMEN/ARCH SHNG
STORY HEIGHT-9.00
INTERIOR WALL-DRYWALL-DECORAT
FLOOR COVER-CARPET
NO. STORIES-2.00
FLOOR COVER-HARD TILE/BRICK
DECOR/MILLWORK-ABOVE AVERAGE
HEAT/AIR-GEO-THERMAL SYS
STRUCTURAL FRAME-WOOD FRAME

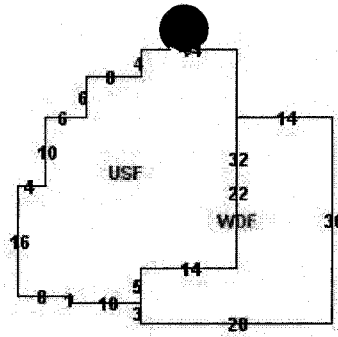

Areas - 5177 Total SF

BASE AREA - 1922
BASE SEMI FIN - 330
CARPORT FIN - 498
CARPORT UNF - 392
OPEN PORCH FIN - 176
PATIO - 213
UPPER STORY FIN - 934
UTILITY UNF - 180
WOOD DECK FIN - 532

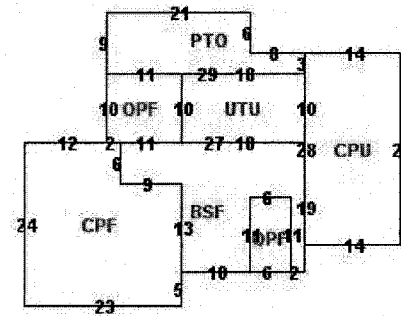
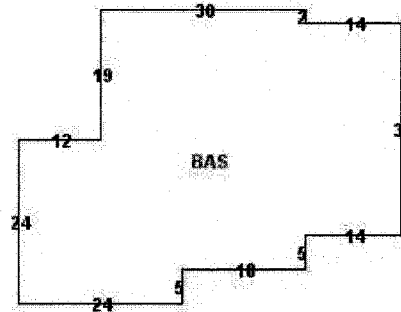

Images

None

The primary use of the assessment data is for the preparation of the current year tax roll. No responsibility or liability is assumed for inaccuracies or errors.

**Ernie Lee Magaha,
Clerk of the Circuit Court of Escambia County Florida**

Receipt Type	Case	Outstanding Amount	0.00
Receipt Number	1145064	Receipt Date	04/28/2010

Case Number	2008 TD 009250
Description	WACHOVIA AS CUST/TR FOR PLYMOUTH PARK TAX SERVICES VS

Action **TAX DEED APPLICATION**

Judge

Received From **WACHOVIA**

On Behalf Of **WACHOVIA AS CUST/TR FOR PLYMOUTH PARK TAX SERVICES**

Total Received	390.00
Net Received	390.00
Change	0.00

Receipt Payments	Amount	Reference Description
Cash	390.00	ONCORE TRANS#791353

Receipt Applications	Amount
Holding	330.00
Service Charge	60.00

Deputy Clerk: mavila Transaction Date 04/28/2010 09:09:59

Comments

Notice to Tax Collector of Application for Tax Deed

TO: Tax Collector of Escambia County

In accordance with Florida Statutes, I,

**WACHOVIA AS CUST/TTEE FOR PLYMOUTH PARK
TAX SERVIC
PO BOX 2288
MORRISTOWN, New Jersey, 07962-2288**

holder of the following tax sale certificate hereby surrender same to the Tax Collector and make tax deed application thereon:

Certificate No.	Parcel ID Number	Date	Legal Description
9250	17-0836-500	05/30/2008	28-2S2-621 LTS 7 & 8 BLK 10 VILLA SEGUNDA PB 3 P 80 OR 2998 P 772 OR 5789 P 1456 SHHET 10

2009 TAX ROLL

HAZEN MELANIE J
1895 DANBURY EAST
OKEMOS, Michigan 48864

I agree to pay all delinquent taxes, redeem all outstanding certificates not in my possession, pay any omitted taxes, and pay current taxes, if due, covering the land, and pay any interest earned (a) on tax certificates not in my possession, (b) on omitted taxes or (c) on delinquent taxes. I also agree to pay all Tax Collector's fees, ownership and encumbrance reports costs, Clerk of the Court costs, charges and fees and Sheriff's costs, if applicable. Attached is the above-mentioned tax sale certificate on which this application is based and all other certificates of the same legal description which are in my possession.

ddewitt (Donna Ernwein)
Applicant's Signature

04/14/2010
Date

TAX COLLECTOR'S CERTIFICATION

**Application
Date / Number
Apr 14, 2010 / 2011**

This is to certify that the holder listed below of Tax Sale Certificate Number **2008 / 9250** , issued the **30th** day of **May, 2008**, and which encumbers the following described property located in the County of Escambia, State of Florida to wit: **Parcel ID Number: 17-0836-500**

Certificate Holder:
WACHOVIA AS CUST/TTEE FOR PLYMOUTH PARK TAX
SERVIC
PO BOX 2288
MORRISTOWN, NEW JERSEY 07962-2288

Property Owner:
HAZEN MELANIE J
1895 DANBURY EAST
OKEMOS, MICHIGAN 48864

Legal Description: 28-2S2-621
LTS 7 & 8 BLK 10 VILLA SEGUNDA PB 3 P 80 OR 2998 P 772 OR 5789 P 1456 SHHET 10

has surrendered same in my office and made written application for tax deed in accordance with Florida Statutes. I certify that the following tax certificates, interest, ownership and encumbrance report fee, and Tax Collector's fees have been paid:

CERTIFICATES OWNED BY APPLICANT AND FILED IN CONNECTION WITH THIS TAX DEED APPLICATION:

Cert. Year	Certificate Number	Date of Sale	Face Amt	T/C Fee	Interest	Total
2008	9250	05/30/08	\$5,033.88	\$0.00	\$604.07	\$5,637.95

CERTIFICATES REDEEMED BY APPLICANT OR INCLUDED (COUNTY) IN CONNECTION WITH THIS APPLICATION:

Cert. Year	Certificate Number	Date of Sale	Face Amt	T/C Fee	Interest	Total
2009	11522	06/01/09	\$4,739.07	\$6.25	\$369.25	\$5,114.57
2005	6701	06/01/05	\$3,195.29	\$6.25	\$159.76	\$3,361.30

1. Total of all Certificates in Applicant's Possession and Cost of the Certificates Redeemed by Applicant or Included (County)
2. Total of Delinquent Taxes Paid by Tax Deed Application
3. Total of Current Taxes Paid by Tax Deed Applicant (2009)
4. Ownership and Encumbrance Report Fee
5. Tax Deed Application Fee
6. Total Certified by Tax Collector to Clerk of Court
7. Clerk of Court Statutory Fee
8. Clerk of Court Certified Mail Charge
9. Clerk of Court Advertising Charge
10. Sheriff's Fee
11. _____
12. Total of Lines 6 thru 11
13. Interest Computed by Clerk of Court Per Florida Statutes.....(%)
14. One-Half of the assessed value of homestead property. If applicable pursuant to section 197.502, F.S.
15. Statutory (Opening) Bid; Total of Lines 12 thru 14
16. Redemption Fee
17. Total Amount to Redeem

\$14,113.82
\$0.00
\$3,941.16
\$150.00
\$75.00
\$18,279.98
\$18,279.98
\$6.25

*Done this 14th day of April, 2010

TAX COLLECTOR, ESCAMBIA COUNTY, FLORIDA

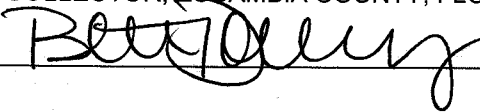
By 

Date of Sale: Sept. 13, 2010

* This certification must be surrendered to the Clerk of the Circuit Court no later than ten days after this date.

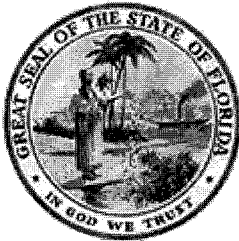

ERNIE LEE MAGAHA
CLERK OF THE CIRCUIT COURT
ESCAMBIA COUNTY, FLORIDA

Tax Deed - Redemption Calculator
Account: 170836500 Certificate Number: 009250 of 2008

Redemption Application Date Interest Rate

	Final Redemption Payment ESTIMATED	Redemption Overpayment ACTUAL
	Auction Date <input type="text" value="09/13/2010"/>	Redemption Date <input type="text" value="09/13/2010"/>
Months	5	5
Tax Collector	<input type="text" value="\$18,279.98"/>	<input type="text" value="\$0.00"/>
Tax Collector Interest	\$1,371.00	\$0.00
Tax Collector Fee	<input type="text" value="\$6.25"/>	<input type="text" value="\$0.00"/>
Total Tax Collector	\$19,657.23	\$0.00
Clerk Fee	<input type="text" value="\$60.00"/>	<input type="text" value="\$0.00"/>
Sheriff Fee	<input type="text" value="\$120.00"/>	<input type="text" value="\$0.00"/>
Legal Advertisement	<input type="text" value="\$210.00"/>	<input type="text" value="\$0.00"/>
App. Fee Interest	\$29.25	\$0.00
Total Clerk	\$419.25	\$0.00
Postage	<input type="text" value="\$60.00"/>	<input type="text" value="\$0.00"/>
Researcher Copies	<input type="text" value="\$40.00"/>	<input type="text" value="\$0.00"/>
Total Redemption Amount	\$20,176.48	\$0.00
	Repayment Overpayment Refund Amount	<input type="text" value="\$20,176.48"/>

Notes ACTUAL SHERIFF \$40.00 COM FEE \$
 5/10/2010 LYNN W/ BAC TAX SERVICES CALLED FOR QUOTE, FAXED
 PAYOFF TO 866-207-0571. HS

Amount needed to redeem property

ERNIE LEE MAGAHA
CLERK OF THE CIRCUIT COURT

ARCHIVES AND RECORDS
CHILD SUPPORT
CIRCUIT CIVIL
CIRCUIT CRIMINAL
COUNTY CIVIL
COUNTY CRIMINAL
DOMESTIC RELATIONS
FAMILY LAW
JURY ASSEMBLY
JUVENILE
MENTAL HEALTH
MIS
OPERATIONAL SERVICES
PROBATE
TRAFFIC

BRANCH OFFICES
ARCHIVES AND RECORDS
JUVENILE DIVISION
CENTURY

CLERK TO THE BOARD OF
COUNTY COMMISSIONERS

OFFICIAL RECORDS
COUNTY TREASURY
AUDITOR

COUNTY OF ESCAMBIA
OFFICE OF THE
CLERK OF THE CIRCUIT COURT

FAX COVER SHEET

FAX NUMBER TRANSMITTED TO: 1-866-207-0171

To: Lynn

Of: BAC Tax Service

From: Escambia County Official Records/Tax Deeds 850-595-3930/850-595-3793
Fax 850-595-4827

Client/Matter: pay ff amount of 09250/08

Date: 5/11/10

DOCUMENTS	NUMBER OF PAGES*
	3

COMMENTS:

Please see attached

* NUMBER OF PAGES, INCLUDING COVER:

Search Property
 Property Sheet
 Lien Holder's
 Sold To
 Redem.
 Forms
 Courtview

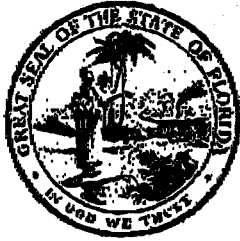

ERNIE LEE MAGAHA
CLERK OF THE CIRCUIT COURT
ESCAMBIA COUNTY, FLORIDA

Tax Deed - Redemption Calculator

Account: 170836500 Certificate Number: 009250 of 2008

Redemption No Application Date 04/14/2010 Interest Rate 18%

	Final Redemption Payment ESTIMATED	Redemption Overpayment ACTUAL
	Auction Date <u>09/13/2010</u>	Redemption Date <u>09/13/2010</u> <input checked="" type="checkbox"/>
Months	5	5
Tax Collector	<u>\$18,279.98</u>	<u>\$0.00</u>
Tax Collector Interest	<u>\$1,371.00</u>	<u>\$0.00</u>
Tax Collector Fee	<u>\$6.25</u>	<u>\$0.00</u>
Total Tax Collector	<u>\$19,657.23</u>	<u>\$0.00</u>
Clerk Fee	<u>\$60.00</u>	<u>\$0.00</u>
Sheriff Fee	<u>\$120.00</u>	<u>\$0.00</u>
Legal Advertisement	<u>\$210.00</u>	<u>\$0.00</u>
App. Fee Interest	<u>\$29.25</u>	<u>\$0.00</u>
Total Clerk	<u>\$419.25</u>	<u>\$0.00</u>
Postage	<u>\$60.00</u>	<u>\$0.00</u>
Researcher Copies	<u>\$40.00</u>	<u>\$0.00</u>
Total Redemption Amount	<u>\$20,176.48</u>	<u>\$0.00</u>
	Repayment Overpayment Refund Amount	<u>\$20,176.48</u>

Notes: ACTUAL SHERIFF \$40.00 COM FEE \$
 5/10/2010 LYNN W/ BAC TAX SERVICES CALLED FOR QUOTE, FAXED
 PAYOFF TO 866-207-0571. HS

Amount needed to redeem property

S411E-05

ENTER/UPDATE TAX DATA

5/13/10

LGALLANT

Bank of America Home Loan

08:01:07

ACCT NUMBER: 037073642

ESCROW TYPE: 90

CUSTOMER NAME: JON M & MELANIE J HAZEN

ADDRESS: 807 ARIOLA DRIVE

CITY/STATE: PENSACOLA BEACH, FL

ZIP: 32561

STATE CODE: 10

LEGAL DESCRIPTION OF PROPERTY: LOT TRACTBLOCK BOOK PAGES

AMOUNT DUE

20,176.48

TAX I.D.#/DESC.

17-0836-500

5.31.10

Tax Authority Name/Address:

8033

ESCAMBIA CLERK OF COURT

ATTN: TAX DEED DIVISION

221 PALAFOX PL, SUITE #110

PENSACOLA

FL 32502

F12=Previous

**Ernie Lee Magaha,
Clerk of the Circuit Court of Escambia County Florida**

Receipt Type	Case	Outstanding Amount	0.00
Receipt Number	1151580	Receipt Date	05/14/2010
Case Number	2008 TD 009250		
Description	WACHOVIA AS CUST/TR FOR PLYMOUTH PARK TAX SERVICES VS		
Action	TAX DEED REDEMPTION		
Judge			
Received From	BANK OF AMERICA HOME LOAN		
On Behalf Of	WACHOVIA AS CUST/TR FOR PLYMOUTH PARK TAX SERVICES		

Total Received	20,176.48
Net Received	20,176.48
Change	0.00

Receipt Payments	Amount	Reference Description
Check	20,176.48	2112254446

Receipt Applications	Amount
Holding	20,076.48
Service Charge	100.00

Deputy Clerk: hms Transaction Date 05/14/2010 10:42:52

Comments

ERNIE LEE MAGAHA
 CLERK OF THE CIRCUIT COURT
 ARCHIVES AND RECORDS
 CHILDSUPPORT
 CIRCUIT CIVIL
 CIRCUIT CRIMINAL
 COUNTY CIVIL
 COUNTY CRIMINAL
 DOMESTIC RELATIONS
 FAMILY LAW
 JURY ASSEMBLY
 JUVENILE
 MENTAL HEALTH
 MIS
 OPERATIONAL SERVICES
 PROBATE
 TRAFFIC

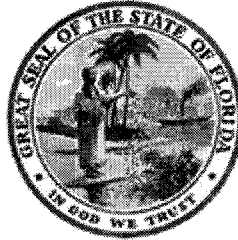

BRANCH OFFICES
ARCHIVES AND RECORDS
JUVENILE DIVISION
CENTURY

CLERK TO THE BOARD OF
 COUNTY COMMISSIONERS
 OFFICIAL RECORDS
 COUNTY TREASURY
 AUDITOR

COUNTY OF ESCAMBIA
OFFICE OF THE
CLERK OF THE CIRCUIT COURT

Case # 2008 TD 009250
Redeemed Date 05/14/2010

Name BANK OF AMERICA HOME LOANS DEUTSCHE BANK

Clerk's Total = TAXDEED	\$419.25
Due Tax Collector = TAXDEED	\$19,657.23
Postage = TD2	\$60.00
ResearcherCopies = TD6	\$40.00

Apply Docket Codes

• For Office Use Only

Date	Docket	Desc	Amount Owed	Amount Due	Payee Name
05/30/2008	TD1	TAX DEED APPLICATION Receipt: 1145064 Date: 04/28/2010	60.00	0.00	
05/30/2008	TAXDEED	TAX DEED CERTIFICATES Receipt: 1145064 Date: 04/28/2010	330.00	0.00	
05/14/2010	TD6	TITLE RESEARCHER COPY CHARGES	40.00	40.00	
05/14/2010	TD2	POSTAGE TAX DEEDS	60.00	60.00	
05/14/2010	TAXDEED	TAXDEED Due Tax Collector	19,657.23	19,657.23	
05/14/2010	TAXDEED	TAXDEED Clerk's Total	419.25	419.25	

FINANCIAL SUMMARY

Rcd	Docket Application	Owed	Paid	Dismissed	Due
1	Service Charge	\$160.00	\$60.00	\$0.00	\$100.00
2	Holding	\$20,406.48	\$330.00	\$0.00	\$20,076.48
	TOTAL	\$20,566.48	\$390.00	\$0.00	\$20,176.48

ERNIE LEE MAGAHA
 CLERK OF THE CIRCUIT COURT
 ARCHIVES AND RECORDS
 CHILDSUPPORT
 CIRCUIT CIVIL
 CIRCUIT CRIMINAL
 COUNTY CIVIL
 COUNTY CRIMINAL
 DOMESTIC RELATIONS
 FAMILY LAW
 JURY ASSEMBLY
 JUVENILE
 MENTAL HEALTH
 MIS
 OPERATIONAL SERVICES
 PROBATE
 TRAFFIC

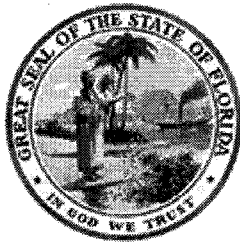

BRANCH OFFICES
ARCHIVES AND RECORDS
JUVENILE DIVISION
CENTURY

CLERK TO THE BOARD OF
 COUNTY COMMISSIONERS
 OFFICIAL RECORDS
 COUNTY TREASURY
 AUDITOR

COUNTY OF ESCAMBIA
OFFICE OF THE
CLERK OF THE CIRCUIT COURT

ERNIE LEE MAGAHA, CLERK OF THE CIRCUIT COURT
Tax Certificate Redeemed From Sale
Account: 170836500 Certificate Number: 009250 of 2008

Payor: BANK OF AMERICA HOME LOANS DEUTSCHE BANK Date 05/14/2010

Clerk's Check #	2112254446	Clerk's Total	\$419.25
Tax Collector Check #	1	Tax Collector's Total	\$19,657.23
		Postage	\$60.00
		Researcher Copies	\$40.00
		Total Received	\$20,176.48

ERNIE LEE MAGAHA
 Clerk of the Circuit Court

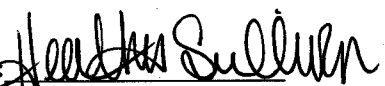
Received By: 
 Deputy Clerk

Escambia County Government Complex • 221 Palafox Place Ste 110 • PENSACOLA, FLORIDA 32502
(850) 595-3793 • FAX (850) 595-4827 • <http://www.clerk.co.escambia.fl.us>

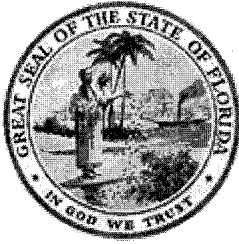

ERNIE LEE MAGAHA
CLERK OF THE CIRCUIT COURT
ESCAMBIA COUNTY, FLORIDA

Tax Deed - Redemption Calculator

Account: 17083650 Certificate Number: 009250 of 2008

Redemption Yes
 Application Date
 Interest Rate

	Final Redemption Payment ESTIMATED	Redemption Overpayment ACTUAL
	Auction Date <input type="text" value="09/13/2010"/>	Redemption Date <input type="text" value="05/14/2010"/>
Months	5	1
Tax Collector	<input type="text" value="\$18,279.98"/>	<input type="text" value="\$18,279.98"/>
Tax Collector Interest	\$1,371.00	\$274.20
Tax Collector Fee	<input type="text" value="\$6.25"/>	<input type="text" value="\$6.25"/>
Total Tax Collector	\$19,657.23	\$18,560.43
Clerk Fee	<input type="text" value="\$60.00"/>	<input type="text" value="\$60.00"/>
Sheriff Fee	<input type="text" value="\$120.00"/>	<input type="text" value="\$120.00"/>
Legal Advertisement	<input type="text" value="\$210.00"/>	<input type="text" value="\$210.00"/>
App. Fee Interest	\$29.25	\$5.85
Total Clerk	\$419.25	\$395.85
Postage	<input type="text" value="\$60.00"/>	<input type="text" value="\$60.00"/>
Researcher Copies	<input type="text" value="\$40.00"/>	<input type="text" value="\$40.00"/>
Total Redemption Amount	\$20,176.48	\$19,056.28
	Repayment Overpayment Refund Amount	\$1,120.20 + 120 + 210 = 1450.20

Notes ACTUAL SHERIFF \$40.00 COM FEE \$
 5/10/2010 LYNN W/ BAC TAX SERVICES CALLED FOR QUOTE, FAXED
 PAYOFF TO 866-207-0571. HS

ERNIE LEE MAGAHA
CLERK OF THE COURT & COMPTROLLER
P.O. BOX 333
PENSACOLA, FL 32591-0333
(850) 595-4140
REGISTRY ACCOUNT

Bank of America
PENSACOLA, FLORIDA

63-27
631

9000012311

VOID AFTER 6 MONTHS

PAY

*ONE THOUSAND FOUR HUNDRED FIFTY AND 20/100

JON M & MELANIE J HAZEN

TO THE ORDER OF JON M & MELANIE J HAZEN
807 ARIOLA DRIVE
PENSACOLA BEACH, FL 32561-

DATE

05/19/2010

AMOUNT

1,450.20

Ernie Lee Magaha
ERNIE LEE MAGAHA, CLERK OF THE COURT



⑈9000012311⑈ ⑆063100277⑆ 898033991356⑈

ERNIE LEE MAGAHA
CLERK OF THE COURT & COMPTROLLER

9000012311

Date	Case Number	Description	Amount
05/19/2010	2008 TD 009250	PAYMENT TAX DEEDS	1,450.20

9000012311

Check: 9000012311 05/19/2010 JON M & MELANIE J HAZEN Check Amount: 1,450.20

ERNIE LEE MAGAHA
CLERK OF THE COURT & COMPTROLLER
P.O. BOX 333
PENSACOLA, FL 32591-0333
(850) 595-4140
REGISTRY ACCOUNT

Bank of America
PENSACOLA, FLORIDA
VOID AFTER 6 MONTHS

63-27
631

9000012322

PAY

*TWO THOUSAND EIGHT HUNDRED TWENTY FOUR AND 75/100

WACHOVIA AS TRUSTEE FOR PLYMOUTH PARK TAX SERVICE

TO THE ORDER OF

WACHOVIA AS TRUSTEE FOR PLYMOUTH PARK TAX S P O BOX 2288

MORRISTOWN, NJ 07962

DATE

AMOUNT

05/19/2010

2,824.75

Ernie Lee Magaha
ERNIE LEE MAGAHA, CLERK OF THE COURT



⑈9000012322⑈ ⑆063100277⑆ 898033991356⑈

ERNIE LEE MAGAHA
CLERK OF THE COURT & COMPTROLLER

9000012322

Date	Case Number	Description	Amount
05/19/2010	2008 TD 000867	PAYMENT TAX DEEDS	395.85
05/19/2010	2008 TD 000868	PAYMENT TAX DEEDS	449.65
05/19/2010	2008 TD 000452	PAYMENT TAX DEEDS	395.85
05/19/2010	2008 TD 000048	PAYMENT TAX DEEDS	395.85
05/19/2010	2008 TD 000866	PAYMENT TAX DEEDS	395.85
05/19/2010	2008 TD 009100	PAYMENT TAX DEEDS	395.85
05/19/2010	2008 TD 009250	PAYMENT TAX DEEDS	395.85

9000012322

Check: 9000012322 05/19/2010 WACHOVIA AS TRUSTEE FOR PLYMOUTH PARK TAX SERVICE Check Amount: 2,824.75

THE REVERSE SIDE OF THIS DOCUMENT INCLUDES MICROPRINTED ENDORSEMENT LINES AND ARTIFICIAL WATERMARK - HOLD AT AN ANGLE TO VIEW

ERNIE LEE MAGAHA
CLERK OF THE COURT & COMPTROLLER
P.O. BOX 333
PENSACOLA, FL 32591-0333
(850) 595-4140
REGISTRY ACCOUNT

Bank of America
PENSACOLA, FLORIDA
63-27
631
VOID AFTER 6 MONTHS

9000012309

PAY *EIGHTY FIVE THOUSAND ONE HUNDRED EIGHTY FIVE AND 60/100
JANET HOLLEY TAX COLLECTOR

TO THE ORDER OF JANET HOLLEY TAX COLLECTOR
213 PALAFOX PLACE
PENSACOLA, FL 32502
DATE 05/19/2010
AMOUNT 85,185.60

Ernie Lee Magaha
ERNIE LEE MAGAHA, CLERK OF THE COURT



⑈9000012309⑈ ⑆063100277⑆ 898033991356⑈

ERNIE LEE MAGAHA
CLERK OF THE COURT & COMPTROLLER

9000012309

Date	Case Number	Description	Amount
05/19/2010	2008 TD 009100	PAYMENT TAX DEEDS	5,738.39
05/19/2010	2008 TD 000868	PAYMENT TAX DEEDS	18,180.38
05/19/2010	2008 TD 003815	PAYMENT TAX DEEDS	767.92
05/19/2010	2008 TD 009250	PAYMENT TAX DEEDS	18,560.43
05/19/2010	2008 TD 003387	PAYMENT TAX DEEDS	721.59
05/19/2010	2008 TD 006355	PAYMENT TAX DEEDS	560.97
05/19/2010	2008 TD 000866	PAYMENT TAX DEEDS	13,403.78
05/19/2010	2008 TD 000867	PAYMENT TAX DEEDS	12,206.53
05/19/2010	2008 TD 000048	PAYMENT TAX DEEDS	3,126.15
05/19/2010	2008 TD 000452	PAYMENT TAX DEEDS	7,042.44

There are additional check details for this check that total: 4,877.02

9000012309

Check: 9000012309 05/19/2010 JANET HOLLEY TAX COLLECTOR Check Amount: 85,185.60

2008 td 08905 - 4,877.02

WITNESS AS TO LESSEE(S):

Kathleen C. Hamm
(Signature of 1st Witness)

KATHLEEN C. HAMM
(Type/Print Name of 1st Witness)

Jessie I. Ferrero
(Signature of 2nd Witness)

Jessie I. Ferrero
(Type/Print Name of 2nd Witness)

LESSEE SIGNATURE:

Melaine J. Hazen
Melaine J. Hazen

STATE OF Nevada
COUNTY OF Clark

The foregoing instrument was acknowledged before me this 5 day of October, 2005 by Melanie Hazen and Dwight Jackson who produced _____ as identification.

Carol A. Allen
NOTARY PUBLIC
My Commission Expires: 6/3/06



Prepared by: Sue Smith
Santa Rosa Island Authority
Post Office Box 1208
Pensacola Beach, Florida 32561

Dated this 12th day of October, 2005.

ATTEST:

Secretary

W. McGuire Martin
(Type/Print Name of Secretary)

SANTA ROSA ISLAND AUTHORITY

Chairman

Thomas E. Blas
(Type/Print Name of Chairman)



WITNESSES AS TO SANTA ROSA ISLAND AUTHORITY:

Sue Smith
SUE Smith
(Type/Print Name of Witness)

Lisa Thorsen
Lisa Thorsen
(Type/Print Name of Witness)

STATE OF FLORIDA
COUNTY OF ESCAMBIA

Before me, the undersigned Notary Public, personally appeared Thomas E. Blas and W. McGuire Martin who are personally known to me and known to be the Chairman and Secretary, respectively, of the Santa Rosa Island Authority, and acknowledged that they executed the foregoing instrument for and in the name of said Authority, as its Chairman and Secretary, and caused its seal to be thereto affixed pursuant to due and legal action of said Authority authorizing them to do so. They did (did not) take and oath.

GIVEN under my hand and official seal this the 12th day of October, 2005

Melink Sellers
NOTARY PUBLIC
My commission expires: May 13, 2009

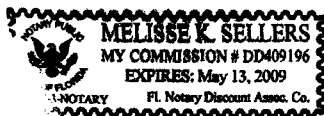

- c. SRIA, Escambia County and Federal Emergency Management Agency ("FEMA") regulations specifically require that none of the area below the Base Flood Elevation (BFE) be designed or used for the purpose of human habitation. Human habitation includes, but is not limited to, working, sleeping, eating, cooking, recreation or a combination thereof.
- d. Periodic inspections may be conducted by the Santa Rosa Island Authority during the progress of construction projects to insure that prescribed construction methods and materials are utilized in order to comply with the objective of eliminating or minimizing flood damage. The Santa Rosa Island Authority reserves the right to make future inspections of the leasehold upon reasonable notice to the Lessee.
- e. Lessee accepts the obligation to abide by current and future regulations regarding flood insurance and building code requirements at Pensacola Beach, and to insure that no additional construction will take place on the leasehold property without first obtaining written approval from the SRIA and issuance of all required permits for said construction.

(5) It is expressly declared to be the intent of the parties that the responsibilities of the undersigned Lessee under this Amendment shall bind Lessee's heirs, administrators, successors and assigns.

(6) It is expressly agreed that upon execution, this Amendment shall be promptly recorded by Lessee in the public records of Escambia County, Florida, and shall encumber the leasehold estate created by the Lease Agreement. Lessee agrees to provide a copy of the recorded amendment to the SRIA upon receipt thereof.

AMENDMENT TO SINGLE FAMILY RESIDENTIAL LEASE AGREEMENT

CONSTRUCTION BELOW THE BASE FLOOD ELEVATION

This amendment is hereby incorporated into and made part of that certain lease agreement previously entered into between the Santa Rosa Island Authority, as an agency of Escambia County, Florida (hereinafter "Lessor" or the "SRIA"), and Gaylord C. Hunt, a married man, which lease agreement is dated April 22, 1957 and recorded in Plat Book 3 Page 80 of the public records of Escambia County, Florida (herein the "Lease Agreement").

Melanie J. Hazen is the Assignee of the Lease as evidenced by that certain Assignment of Lease dated April 29, 1991 and recorded in Official Records Book 2998 Pages 772, public records of Escambia County, Florida;

In consideration of the Santa Rosa Island Authority's approval of the Post Firm Pile Supported Addition, located at 807 Ariola, Lots 7 & 8, Block 10, Villa Segunda, Pensacola Beach, Florida, the undersigned lessee hereby covenants, warrants, and agrees as follows:

- (1) In this amendment, the use of the singular shall include the plural, the use of the masculine shall include the feminine, and the use of the masculine shall also include an owner that is a corporation or partnership.
- (2) The undersigned Lessee covenants and warrants that he is the present owner of the lease agreement and the leasehold estate created by the lease agreement.
- (3) The purpose of this document is to draw attention to certain rules, regulations, and requirements regarding construction on Pensacola Beach. This document is not intended to and does not create or impair any rights or obligation that either party may have under existing laws, codes or regulations.

- (4) Said lease is hereby amended to include the following wording:

As a condition of obtaining SRIA approval, Lessee understands and agrees as follows:

- a. All new and substantial improvement construction at Pensacola Beach is subject to the regulations, which from time to time may be amended, promulgated by the SRIA, Escambia County, and state and federal agencies.
- b. The lease and subdivision plat for the subject leasehold restricts use of the structure thereon to a single family dwelling unit. Conversion to allow for more than one dwelling unit is expressly prohibited under the terms of the lease with the SRIA.

SOUTHERN GUARANTY TITLE COMPANY

4400 BAYOU BLVD., SUITE 13-B, CORDOVA SQUARE

PENSACOLA, FLORIDA 32503

TEL. (850) 478-8121 FAX (850) 476-1437

Email: rcsgrt@aol.com

Janet Holley
Escambia County Tax Collector
P.O. Box 1312
Pensacola, FL 32596

CERTIFICATION: TITLE SEARCH FOR TDA

TAX DEED SALE DATE: 09-13-10

TAX ACCOUNT NO.: 17-0836-500

CERTIFICATE NO.: 2008-9250

In compliance with Section 197.256, Florida Statutes, the following is a list of names and addresses of those persons, firms and/or agencies having legal interest in or claim against the above described property. The above referenced tax sale certificate is being submitted as proper notification of tax deed sale.

YES NO

 Notify City of Pensacola, P.O. Box 12910, 32596

 Notify Escambia County, 190 Governmental Center, 32501

 Homestead for tax year.

Melanie J. Hazen
1895 Danbury East
Okemos, MI 48864
and
807 Ariola Dr.
Pensacola Beach, FL 32561

Santa Rosa Island Authority
P.O. Box 1208
Pensacola, FL 32562
Beach

Certified and delivered to Escambia County Tax Collector,
this 28th day of May, 2010.

SOUTHERN GUARANTY TITLE COMPANY

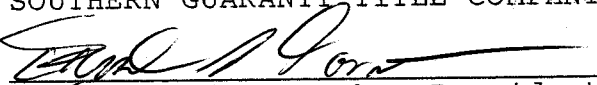
by: Richard S. Combs, President

NOTE: The above listed addresses are based upon current information available, but said addresses are not guaranteed to be true or correct.

OWNERSHIP AND ENCUMBERANCE REPORT

CONTINUATION PAGE

File No.: 7865

May 21, 2010

UNSATISFIED MORTGAGES, LIENS AND JUDGMENTS AFFECTING THE LAND COVERED BY THIS REPORT THAT APPEAR OF RECORD:

1. Subject to terms and conditions of any controlling Santa Rosa Island leases, subleases, lease assignments, or condominium documents applicable to this parcel.
2. Taxes for the year 2007-2008 delinquent. The assessed value is \$513,640.00. Tax ID 17-0836-500.

PLEASE NOTE THE FOLLOWING:

- A. Taxes and Assessments due now or in subsequent years.
- B. Subject to Easements, Restrictions and Covenants of record.
- C. Oil, gas, mineral or any other subsurface rights of any kind or nature.
- D. Encroachments, overlaps, boundary line disputes, and any other matters which would be disclosed by an accurate survey and inspection of the premises.

**OWNERSHIP AND ENCUMBERANCE REPORT
LEGAL DESCRIPTION**

File No.: 7865

May 21, 2010

Lots 7 and 8, Block 10, Villa Segunda, according to the plat thereof recorded in Plat Book 3, Page 80, Public Records of Escambia County, Florida.

Southern Guaranty Title Company

4400 Bayou Blvd., Suite 13B

Pensacola, Florida 32503

Telephone: (850) 478-8121

Facsimile: (850) 476-1437

OWNERSHIP AND ENCUMBERANCE REPORT

File No.: 7865

May 21, 2010

Escambia County Tax Collector
P.O. Box 1312
Pensacola, FL 32569
ATTN: Beth Donnelly

Pursuant to your request, the Company has caused a search to be made of the Public Records of Escambia County, Florida, solely as revealed by records maintained from 05-20-90, through 05-20-10, and said search reveals the following:

1. THE GRANTEE(S) OF THE LAST DEED(S) OF RECORD IS:

Melanie J. Hazen

2. The land covered by this Report is:

LEGAL DESCRIPTION IS ATTACHED HERETO AND MADE A PART HEREOF

3. The following unsatisfied mortgages, liens and judgments affecting the land covered by this Report appear of record:

SEE CONTINUATION PAGE ATTACHED HERETO AND MADE A PART HEREOF

4. Taxes:

SEE CONTINUATION PAGE ATTACHED HERETO AND MADE A PART HEREOF

The foregoing report is prepared and furnished for information only, is not intended to constitute or imply any opinion, warranty, guaranty, insurance, or similar assurance as to the status of title, and no determination has been made of the authenticity of any instrument described or referred to herein. The name search for the purposes of determining applicable judgments and liens is limited to the apparent record owner(s) shown herein. No attempt has been made to determine whether the land is subject to liens or assessments which are not shown as existing liens by the public records. The Company's liability hereunder shall not exceed the cost of this Report, or \$1,000.00 whichever is less.

THIS REPORT SHALL NOT BE USED FOR THE ISSUANCE OF TITLE INSURANCE.

Southern Guaranty Title Company

BY: 
Richard S. Combs

May 21, 2010

ERNIE LEE MAGAHA
CLERK OF THE CIRCUIT COURT



BRANCH OFFICES
ARCHIVES AND RECORDS
JUVENILE DIVISION

CENTURY

ARCHIVES AND RECORDS
CHILD SUPPORT
CIRCUIT CIVIL
CIRCUIT CRIMINAL
COUNTY CIVIL
COUNTY CRIMINAL
DOMESTIC RELATIONS
FAMILY LAW
JURY ASSEMBLY
JUVENILE
MENTAL HEALTH
MIS
OPERATIONAL SERVICES
PROBATE
TRAFFIC

COUNTY OF ESCAMBIA
OFFICE OF THE
CLERK OF THE CIRCUIT COURT

CLERK TO THE BOARD OF
COUNTY COMMISSIONERS

OFFICIAL RECORDS
COUNTY TREASURY
AUDITOR

IMAGING COVER PAGE

This cover page is not a part of the original documents but is necessary to avoid obscuring any information on the original documents.

Case: 2008 TD 009250

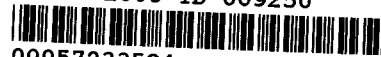

00057233584

Dkt: TD80 Pg#:

27

Original Documents Follow

Maryline Avila

From: "Maryline Avila" <mavila@escambiaclerk.com>
To: "Dana Moye" <dmoye@escambiaclerk.com>
Cc: "Carolyn Holland" <cholland@escambiaclerk.com>; "Brenda Robinson" <brobinson@clerk.co.escambia.fl.us>
Sent: Monday, May 17, 2010 9:06 AM
Subject: Check Request Tax Cert 2008 TD 09250

2008 TD 09250

Please issue checks:

Janet Holley Tax Collector
\$18,560.43(taxes due)

10 - 350

Wachovia as Trustees for Plymouth Park Tax Services
PO BOX 2288
Morristown NJ 07962-2288
\$395.85(\$390.00 app fees, \$5.85 interest)

Jon M & Melanie J Hazen
807 Ariola Dr
Pensacola Beach, FL 32561
\$1,450.20(refund overpayment)

Maryline Avila
Escambia County
Clerk of Circuit Court
Tax Deeds Division
(850) 595-3793
(850) 595-4827
mavila@escambiaclerk.com