

ERNIE LEE MAGAHA
CLERK OF THE CIRCUIT COURT



BRANCH OFFICES
ARCHIVES AND RECORDS
JUVENILE DIVISION

CENTURY

ARCHIVES AND RECORDS
CHILD SUPPORT
CIRCUIT CIVIL
CIRCUIT CRIMINAL
COUNTY CIVIL
COUNTY CRIMINAL
DOMESTIC RELATIONS
FAMILY LAW
JURY ASSEMBLY
JUVENILE
MENTAL HEALTH
MIS
OPERATIONAL SERVICES
PROBATE
TRAFFIC

**COUNTY OF ESCAMBIA
OFFICE OF THE
CLERK OF THE CIRCUIT COURT**

CLERK TO THE BOARD OF
COUNTY COMMISSIONERS

OFFICIAL RECORDS
COUNTY TREASURY
AUDITOR

IMAGING COVER PAGE

This cover page is not a part of the original documents but is necessary to avoid obscuring any information on the original documents

Case: 2008 TD 001396



00086863340

Dkt: TD83 Pg#:

3

Original Documents Follow

TAX COLLECTOR'S CERTIFICATION

**Application
Date / Number
Sep 30, 2010 / 2501**

This is to certify that the holder listed below of Tax Sale Certificate Number **2008 / 1396** , issued the **30th** day of **May, 2008**, and which encumbers the following described property located in the County of Escambia, State of Florida to wit: **Parcel ID Number: 03-1458-000**

Certificate Holder:
HEARTWOOD 3 LLC
PO BOX 5707
FT LAUDERDALE, FLORIDA 33310

Property Owner:
MANN WENDELL
4 PACIFIC ST
PENSACOLA , FLORIDA 32503

Legal Description: 27-1S3-012
LT 1 OAKFIELD ESTATES PB 5 P 5 SEC 27/28/38 T 1S R 30 OR 294 P 203 OR 2172 P 193 OR 5919 P 605 OR 6164 P 1158

has surrendered same in my office and made written application for tax deed in accordance with Florida Statutes. I certify that the following tax certificates, interest, ownership and encumbrance report fee, and Tax Collector's fees have been paid:

CERTIFICATES OWNED BY APPLICANT AND FILED IN CONNECTION WITH THIS TAX DEED APPLICATION:

Cert. Year	Certificate Number	Date of Sale	Face Amt	T/C Fee	Interest	Total
2008	1396	05/30/08	\$757.03	\$0.00	\$109.77	\$866.80

CERTIFICATES REDEEMED BY APPLICANT OR INCLUDED (COUNTY) IN CONNECTION WITH THIS APPLICATION:

Cert. Year	Certificate Number	Date of Sale	Face Amt	T/C Fee	Interest	Total
2010	1969	06/01/10	\$590.04	\$6.25	\$29.50	\$625.79
2009	1984	06/01/09	\$634.29	\$6.25	\$142.72	\$783.26

1. Total of all Certificates in Applicant's Possession and Cost of the Certificates Redeemed by Applicant or Included (County)
2. Total of Delinquent Taxes Paid by Tax Deed Application
3. Total of Current Taxes Paid by Tax Deed Applicant
4. Ownership and Encumbrance Report Fee
5. Tax Deed Application Fee
6. Total Certified by Tax Collector to Clerk of Court
7. Clerk of Court Statutory Fee
8. Clerk of Court Certified Mail Charge
9. Clerk of Court Advertising Charge
10. Sheriff's Fee
11. _____
12. Total of Lines 6 thru 11
13. Interest Computed by Clerk of Court Per Florida Statutes.....(%)
14. One-Half of the assessed value of homestead property. If applicable pursuant to section 197.502, F.S.
15. Statutory (Opening) Bid; Total of Lines 12 thru 14
16. Redemption Fee
17. Total Amount to Redeem

\$2,275.85
\$0.00
\$150.00
\$75.00
\$2,500.85
\$2,500.85
\$29,044.00
\$6.25

*Done this 30th day of September, 2010

TAX COLLECTOR, ESCAMBIA COUNTY, FLORIDA

By *Glenda Makum*

Date of Sale: March 7, 2011

* This certification must be surrendered to the Clerk of the Circuit Court no later than ten days after this date.

Notice to Tax Collector of Application for Tax Deed

TO: Tax Collector of Escambia County

In accordance with Florida Statutes, I,

**HEARTWOOD 3 LLC
PO BOX 5707
FT LAUDERDALE, Florida, 33310**

holder of the following tax sale certificate hereby surrender same to the Tax Collector and make tax deed application thereon:

Certificate No.	Parcel ID Number	Date	Legal Description
1396	03-1458-000	05/30/2008	27-1S3-012 LT 1 OAKFIELD ESTATES PB 5 P 5 SEC 27/28/38 T 1S R 30 OR 294 P 203 OR 2172 P 193 OR 5919 P 605 OR 6164 P 1158

2009 TAX ROLL

MANN WENDELL
4 PACIFIC ST
PENSACOLA , Florida 32503

I agree to pay all delinquent taxes, redeem all outstanding certificates not in my possession, pay any omitted taxes, and pay current taxes, if due, covering the land, and pay any interest earned (a) on tax certificates not in my possession, (b) on omitted taxes or (c) on delinquent taxes. I also agree to pay all Tax Collector's fees, ownership and encumbrance reports costs, Clerk of the Court costs, charges and fees and Sheriff's costs, if applicable. Attached is the above-mentioned tax sale certificate on which this application is based and all other certificates of the same legal description which are in my possession.

taxcerttda (Ivette Renje)

Applicant's Signature

09/30/2010

Date

ERNIE LEE MAGAHA
CLERK OF THE CIRCUIT COURT



BRANCH OFFICES
ARCHIVES AND RECORDS
JUVENILE DIVISION

ARCHIVES AND RECORDS
CHILD SUPPORT
CIRCUIT CIVIL
CIRCUIT CRIMINAL
COUNTY CIVIL
COUNTY CRIMINAL
DOMESTIC RELATIONS
FAMILY LAW
JURY ASSEMBLY
JUVENILE
MENTAL HEALTH
MIS
OPERATIONAL SERVICES
PROBATE
TRAFFIC

COUNTY OF ESCAMBIA
OFFICE OF THE
CLERK OF THE CIRCUIT COURT

CENTURY

CLERK TO THE BOARD OF
COUNTY COMMISSIONERS

OFFICIAL RECORDS
COUNTY TREASURY
AUDITOR

IMAGING COVER PAGE

This cover page is not a part of the original documents but is
necessary to avoid obscuring any information on
the original documents

Case: 2008 TD 001396



00047053994

Dkt: TD82 Pg#:

8

Original Documents Follow

Southern Guaranty Title Company

4400 Bayou Blvd., Suite 13B

Pensacola, Florida 32503

Telephone: (850) 478-8121

Facsimile: (850) 476-1437

11-169

OWNERSHIP AND ENCUMBERANCE REPORT

File No.: 8392

November 18, 2010

Escambia County Tax Collector
P.O. Box 1312
Pensacola, FL 32569
ATTN: Glenda Mahuron

Pursuant to your request, the Company has caused a search to be made of the Public Records of Escambia County, Florida, solely as revealed by records maintained from 11-16-90, through 11-16-10, and said search reveals the following:

1. THE GRANTEE(S) OF THE LAST DEED(S) OF RECORD IS:

Wendell Mann

2. The land covered by this Report is:

LEGAL DESCRIPTION IS ATTACHED HERETO AND MADE A PART HEREOF

3. The following unsatisfied mortgages, liens and judgments affecting the land covered by this Report appear of record:

SEE CONTINUATION PAGE ATTACHED HERETO AND MADE A PART HEREOF

4. Taxes:

SEE CONTINUATION PAGE ATTACHED HERETO AND MADE A PART HEREOF

The foregoing report is prepared and furnished for information only, is not intended to constitute or imply any opinion, warranty, guaranty, insurance, or similar assurance as to the status of title, and no determination has been made of the authenticity of any instrument described or referred to herein. The name search for the purposes of determining applicable judgments and liens is limited to the apparent record owner(s) shown herein, No attempt has been made to determine whether the land is subject to liens or assessments which are not shown as existing liens by the public records. The Company's liability hereunder shall not exceed the cost of this Report, or \$1,000.00 whichever is less.

THIS REPORT SHALL NOT BE USED FOR THE ISSUANCE OF TITLE INSURANCE.

Southern Guaranty Title Company

BY: 

Richard S. Combs

November 18, 2010

**OWNERSHIP AND ENCUMBERANCE REPORT
LEGAL DESCRIPTION**

File No.: 8392

November 18, 2010

Lot 1, Oakfield Estates, according to the plat thereof recorded in Plat Book 5, Page 5, Public Records of Escambia County, Florida.

OWNERSHIP AND ENCUMBERANCE REPORT

CONTINUATION PAGE

File No.: 8392

November 18, 2010

UNSATISFIED MORTGAGES, LIENS AND JUDGMENTS AFFECTING THE LAND COVERED BY THIS REPORT THAT APPEAR OF RECORD:

1. Certificate of Delinquency recorded in O.R. Book 6647, page 412, filed by Sarah E. Gates.
2. Taxes for the year 2007-2009 delinquent. The assessed value is \$56,157.00. Tax ID 03-1458-000.

PLEASE NOTE THE FOLLOWING:

- A. Taxes and Assessments due now or in subsequent years.
- B. Subject to Easements, Restrictions and Covenants of record.
- C. Oil, gas, mineral or any other subsurface rights of any kind or nature.
- D. Encroachments, overlaps, boundary line disputes, and any other matters which would be disclosed by an accurate survey and inspection of the premises.

SOUTHERN GUARANTY TITLE COMPANY

4400 BAYOU BLVD., SUITE 13-B, CORDOVA SQUARE

PENSACOLA, FLORIDA 32503

TEL. (850) 478-8121 FAX (850) 476-1437

Email: rcsgt@aol.com

Janet Holley
Escambia County Tax Collector
P.O. Box 1312
Pensacola, FL 32596

CERTIFICATION: TITLE SEARCH FOR TDA

TAX DEED SALE DATE: March 7, 2011

TAX ACCOUNT NO.: 03-1458-000

CERTIFICATE NO.: 2008-1396

In compliance with Section 197.256, Florida Statutes, the following is a list of names and addresses of those persons, firms and/or agencies having legal interest in or claim against the above described property. The above referenced tax sale certificate is being submitted as proper notification of tax deed sale.

YES NO

 X Notify City of Pensacola, P.O. Box 12910, 32596

X Notify Escambia County, 190 Governmental Center, 32501

X Homestead for 2010 tax year.

Wendell Mann
4 Pacific St.
Pensacola, FL 32503

Sarah E. Gates
425 Lakeview Ave.
Cantonment, FL 32533

Certified and delivered to Escambia County Tax Collector,
this 3rd day of December, 2010.

SOUTHERN GUARANTY TITLE COMPANY

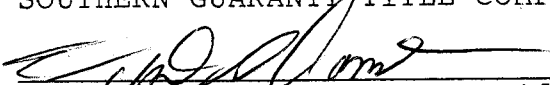
by: Richard S. Combs, President

NOTE: The above listed addresses are based upon current information available, but said addresses are not guaranteed to be true or correct.

QUITCLAIM DEED

This Quitclaim Deed made by **MARJORIE O. MANN**, an unmarried widow, herein called Grantor, to **MARJORIE O. MANN** and **WENDELL MANN**, as joint tenants with right of survivorship, Grantees, whose post office address is: 4 Pacific Street, Pensacola, Florida 32503 (The term "Grantor" and "Grantees" include all the parties in each capacity to this instrument and their respective heirs, personal representatives, successor and assigns.)

WITNESSETH that Grantor, in consideration of TEN (\$10.00) DOLLARS and other good and valuable consideration, receipt whereof is hereby acknowledged, hereby remises, releases and quitclaims unto the Grantees all the right, title, interest, claim and demand which the Grantor has in and to the following described real property in Escambia County, Florida, to-wit:

Lot 1, Oakfield Estates, a subdivision of a portion of Sections 27, 28 and 38, Township 1 South, Range 30 West, Escambia County, Florida, according to plat of said subdivision recorded in Plat Book 5, at Page 5, of the public records of said county, all of said property lying and being in Escambia County, Florida.

Property Appraiser's Parcel Identification No. 27-1S-30-1204-000-010

TO HAVE AND TO HOLD the same together with all and singular the appurtenances thereunto belonging or in anywise appertaining, and all of the estate, right, title, interest, and claim whatsoever of the Grantor, either in law or in equity, to the only proper use, benefit, and behoof of the Grantees and Grantees's assigns forever.

IN WITNESS WHEREOF, Grantor signed and sealed this deed on the 11th day of January, 2005.

Signed and delivered in the presence of:

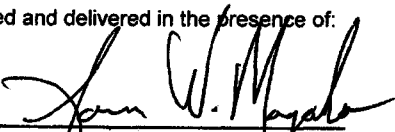

Witness - James W. Magaha

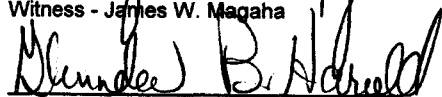
MARJORIE O. MANN

Witness - Glenda B. Harold

STATE OF FLORIDA
COUNTY OF ESCAMBIA

I HEREBY CERTIFY that on this day before me, an officer duly authorized in the state and county aforesaid to take acknowledgments, personally appeared MARJORIE O. MANN, who executed the foregoing instrument and who respectively provided her Florida Driver's Licenses number MS00-532-27-943 as identification.

NOTARY PUBLIC - State of Florida

This instrument prepared by:

James W. Magaha, Esquire
Florida Bar No. 394327
812 N. Spring Street
Pensacola, FL 32501
(850) 438-6224

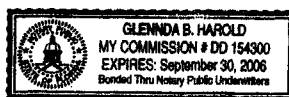

STATE OF FLORIDA

OFFICE of VITAL STATISTICS
 CERTIFIED COPY

FLORIDA CERTIFICATE OF DEATH

10M
 10K

LOCAL FILE NO. 2145

1. DECEDENT'S NAME (First, Middle, Last, Suffix) Marjorie Lewis Mann		2. SEX Female	
3. DATE OF BIRTH (Month, Day, Year) December 3, 1927		4a. AGE-Last Birthday (Years) 78	4b. UNDER 1 YEAR Months _____ Days _____
4. SOCIAL SECURITY NUMBER [REDACTED]		7. BIRTHPLACE (City and State or Foreign Country) Calhoun, Louisiana	8. COUNTY OF DEATH Escambia
9. PLACE OF DEATH (Check only one) HOSPITAL: <input checked="" type="checkbox"/> Inpatient _____ Emergency Room/Outpatient _____ Dead on Arrival _____ NON-HOSPITAL: _____ Hospice Facility _____ Nursing Home/Long Term Care Facility _____ Other (Specify) _____		5. DATE OF DEATH (Month, Day, Year) October 1, 2006	
10. FACILITY NAME (If not institution, give street address) Baptist Hospital		11a. CITY, TOWN, OR LOCATION OF DEATH Pensacola	11b. INSIDE CITY LIMITS? <input checked="" type="checkbox"/> Yes _____ No
12. MARITAL STATUS (Specify) ____ Married _____ Married, but Separated _____ Widowed <input checked="" type="checkbox"/> Divorced _____ Never Married		13. SURVIVING SPOUSE'S NAME (If wife, give maiden name)	
14a. RESIDENCE - STATE Florida		14b. COUNTY Escambia	14c. CITY, TOWN, OR LOCATION Pensacola
14d. STREET ADDRESS 4 Pacific Street		14e. APT. NO.	14f. ZIP CODE 32503
15a. DECEDENT'S USUAL OCCUPATION (Indicate type of work done during most of working life) Homemaker		15b. KIND OF BUSINESS/INDUSTRY Own Home	
16. DECEDENT'S RACE (Specify the race/races to indicate what decedent considered himself/herself to be. More than one race may be specified.) <input checked="" type="checkbox"/> White _____ Black or African American _____ American Indian or Alaskan Native (Specify tribe) _____ _____ Asian Indian _____ Chinese _____ Filipino _____ Japanese _____ Korean _____ Vietnamese _____ Other Asian (Specify) _____ _____ Native Hawaiian _____ Guamanian or Chamorro _____ Samoan _____ Other Pacific Isl. (Specify) _____ Other (Specify) _____			
17. DECEDENT OF HISPANIC OR HAITIAN ORIGIN? (Specify if decedent was of Hispanic or Haitian Origin.) _____ Yes (If Yes, specify) <input checked="" type="checkbox"/> No _____ Mexican _____ Puerto Rican _____ Cuban _____ Central/South American _____ Other Hispanic (Specify) _____ Haitian _____			
18. DECEDENT'S EDUCATION (Specify the decedent's highest degree or level of school completed at time of death.) _____ 8th or less <input checked="" type="checkbox"/> High school but no diploma _____ High school diploma or GED _____ College but no degree _____ College degree (Specify): _____ Associate _____ Bachelor's _____ Master's _____ Doctorate			19. WAS DECEDENT EVER IN U.S. ARMED FORCES? _____ Yes <input checked="" type="checkbox"/> No
20. FATHER'S NAME (First, Middle, Last, Suffix) James E. Lewis		21. MOTHER'S NAME (First, Middle, Last, Suffix) Oma E. Lewis	
22a. INFORMANT'S NAME Wendell Mann		22b. RELATIONSHIP TO DECEDENT Son	22c. INFORMANT'S MAILING - STATE Florida
23a. CITY OR TOWN Pensacola	23b. STREET ADDRESS 4 Pacific Street	23c. ZIP CODE 32503	
24. PLACE OF DISPOSITION (Name of cemetery, crematory, or other place) Hughes Cremation Center		25a. LOCATION - STATE Alabama	25b. LOCATION - CITY OR TOWN Daphne
26a. METHOD OF DISPOSITION _____ Burial _____ Entombment _____ Cremation _____ Donation <input checked="" type="checkbox"/> Removal from State _____ Other (Specify) _____			
26b. IF CREMATION, DONATION OR BURIAL AT SEA, WAS MEDICAL EXAMINER APPROVAL GRANTED? _____ Yes _____ No		27a. LICENSE NUMBER (of Licensee) FE-6136	27b. SIGNATURE OF FUNERAL SERVICE LICENSEE OR PERSON ACTING AS SUCH <i>[Signature]</i>
28. NAME OF FUNERAL FACILITY Trahan Family Funeral Home		28a. FACILITY'S MAILING - STATE Florida	
28b. CITY OR TOWN Pensacola	28c. STREET ADDRESS 430 Beverly Parkway	28d. ZIP CODE 32505	
30. CERTIFIER: <input checked="" type="checkbox"/> Certifying Physician - To the best of my knowledge, death occurred at the time, date and place, and due to the cause(s) and manner stated. (Check one) _____ Medical Examiner - On the basis of examination, and/or investigation, in my opinion, death occurred at the time, date and place, due to the cause(s) and manner stated.			
31a. (Signature and Title of Certifier) <i>[Signature]</i>		31b. DATE SIGNED (mm/dd/yyyy) 10/05/2006	32. TIME OF DEATH (24 Hr.) 1940
34a. LICENSE NUMBER (of Certifier) ME0062467		34b. CERTIFIER'S NAME Dr. Thomas Tan, M.D.	
35a. CERTIFIER'S STATE Florida		35b. CITY OR TOWN Pensacola	35c. NAME OF ATTENDING PHYSICIAN (If other than Certifier)
37. SUBREGISTRAR - Signature and Date <i>[Signature]</i>		38a. LOCAL REGISTRAR - Signature <i>[Signature]</i>	38b. DATE FILED BY REGISTRAR (Mo., Day, Yr.) OCT 13 2006

DEMOGRAPHIC INFORMATION TO BE COMPLETE BY FUNERAL DIRECTOR

MEDICAL CERTIFIER

State of Florida, Department of Health - Vital Statistics

VOID IF ALTERED OR ERASED

Jeanie S. Carpenter
CHIEF DEPUTY REGISTRAR

JUN 05 2007

THE ABOVE SIGNATURE CERTIFIES THAT THIS IS A TRUE AND CORRECT COPY OF THE OFFICIAL RECORD ON FILE IN THIS OFFICE.
WARNING: THIS DOCUMENT IS PRINTED OR PHOTOCOPIED ON SECURITY PAPER WITH A WATERMARK OF THE GREAT SEAL OF THE STATE OF FLORIDA ON THE FRONT, AND THE BACK CONTAINS SPECIAL LINES WITH TEXT AND SEALS IN THERMOCHROMIC INK.



23597643

CERTIFICATION OF VITAL RECORD

* 2 3 5 9 7 6 4 3 *

VOID IF ALTERED OR ERASED



DH FORM 1946 (08-04)

IN THE CIRCUIT COURT OF FLORIDA
FIRST JUDICIAL CIRCUIT, IN AND
FOR ESCAMBIA COUNTY, CIVIL ACTION

CASE NO.: 07-0101605-DR JD/DIV: V
UCN: 17 2007 DR 101605 XXXX JV

GATES, SARAH E.
425 LAKEVIEW AVE
CANTONMENT, FL 32533-
Petitioner.

vs.

MANN, WENDELL
4 PACIFIC STREET
PENSACOLA, FL 32503-0000
Respondent.

ERNIE LEE MAGAHA
CLERK OF CIRCUIT COURT
ESCAMBIA COUNTY FL

2010 OCT 14 P 12:47

DOMESTIC RELATIONS
FILED & RECORDED

JUDGMENT/CERTIFICATE OF DELINQUENCY

The undersigned, being the duly authorized local depository for court-ordered support payments pursuant to F.S. 61.181, in ESCAMBIA County, certifies that MANN, WENDELL has failed to pay into the depository the court-ordered support payment mandated by the current Support Order in this cause. As of this date, the total support arrearage is \$5,094.00 balance at terms, not including any costs or fees. Statutory interest automatically accrues on all past due support pursuant to F.S.55.03.

I further certify that MANN, WENDELL was issued a Notice of Delinquency on 12/21/2009, and 30 or more days have elapsed since the referenced delinquent payment was due. Pursuant to F.S. 61.14 this Certificate is a Final Judgment by operation of law for all past due and future payments together with all applicable costs and fees as provided by law for which execution may issue and which has the full force, effect and attributes of a Judgment entered by a Court in the State of Florida.

Dated October 14, 2010.

ESCAMBIA CTY CLERK OF CIRCUIT COURT ERNIE LEE MAGAHA

By:  Deputy Clerk

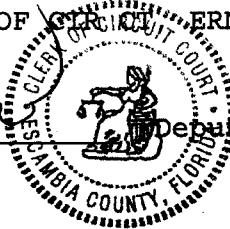

THE REVERSE SIDE OF THIS DOCUMENT INCLUDES MICROPRINTED EQUIPMENT IDENTIFICATION AND SECURITY INFORMATION.
ERNIE LEE MACAHA
CLERK OF THE COURT & COMPTROLLER
P.O. BOX 333
PENSACOLA, FL 32501-0333
(850) 595-4140
REGISTRY ACCOUNT

Bank of America
PENSACOLA, FLORIDA
VOID AFTER 6 MONTHS

9000013726

PAY FIFTEEN THOUSAND ONE HUNDRED EIGHTY TWO AND 20/100

JANET HOLLEY TAX COLLECTOR

TO THE ORDER OF JANET HOLLEY TAX COLLECTOR
213 PALAFOX PLACE
PENSACOLA, FL 32501

DATE: 01/18/2011 AMOUNT: 15,182.20

Ernie Lee Macaha
ERNIE LEE MACAHA, CLERK OF THE COURT & COMPTROLLER



⑈9000013726⑈ ⑆063100277⑆ 898033991356⑈

ERNIE LEE MACAHA
CLERK OF THE COURT & COMPTROLLER

9000013726

Date	Case Number	Description	Amount
01/18/2011	2008 TD 003140	PAYMENT TAX DEEDS	3,010.73
01/18/2011	2008 TD 003594	PAYMENT TAX DEEDS	2,320.63
01/18/2011	2008 TD 001296	PAYMENT TAX DEEDS	2,657.15
01/18/2011	2008 TD 005111	PAYMENT TAX DEEDS	4,073.79
01/18/2011	2008 TD 005112	PAYMENT TAX DEEDS	3,120.90

[Handwritten signature]

9000013726

Check: 9000013726 01/18/2011 JANET HOLLEY TAX COLLECTOR Check Amount: 15,182.20

ERNIE LEE MAGAHA
CLERK OF THE COURT & COMPTROLLER
P.O. BOX 333
PENSACOLA, FL 32591-0333
(850) 595-4140
REGISTRY ACCOUNT

Bank of America
PENSACOLA, FLORIDA

9000013724

53-27
631

VOID AFTER 6 MONTHS

PAY

*EIGHT HUNDRED TWENTY SIX AND 80/100

HEARTWOOD 3 LLC

TO THE
ORDER
OF

HEARTWOOD 3 LLC
P O BOX 5707
FORT LAUDERDALE, FL 33310

DATE

AMOUNT

01/18/2011

826.80

Ernie Lee Magaha
ERNIE LEE MAGAHA, CLERK OF THE COURT



⑈9000013724⑈ ⑆063100277⑆ 898033991356⑈

ERNIE LEE MAGAHA
CLERK OF THE COURT & COMPTROLLER

9000013724

Date	Case Number	Description	Amount
01/18/2011	2008 TD 003412	PAYMENT TAX DEEDS	413.40
01/18/2011	2008 TD 001396	PAYMENT TAX DEEDS	413.40

Check: 9000013724 01/18/2011 HEARTWOOD 3 LLC Check Amount: 826.80

9000013724

826.80

ERNIE LEE MAGAHA
CLERK OF THE COURT & COMPTROLLER
P.O. BOX 333
PENSACOLA, FL 32531-0333
(850) 595-4140
REGISTRY ACCOUNT

Bank of America
PENSACOLA, FLORIDA
VOID AFTER 6 MONTHS

9000013729

*FOUR HUNDRED SIXTEEN AND 73/100

PAY

MICHAEL MABIRE

TO THE ORDER OF
MICHAEL MABIRE
P O BOX 30664
PENSACOLA, FL 32503

DATE AMOUNT
01/18/2011 416.73

Ernie Lee Magaha
ERNIE LEE MAGAHA, CLERK OF THE COURT



⑈9000013729⑈ ⑆063100277⑆ 898033991356⑈

ERNIE LEE MAGAHA
CLERK OF THE COURT & COMPTROLLER

9000013729

Date	Case Number	Description	Amount
01/18/2011	2008 TD 001396	PAYMENT TAX DEEDS	416.73

Check: 9000013729 01/18/2011 MICHAEL MABIRE

Check Amount: 416.73

9000013729



**ERNIE LEE MAGAHA
CLERK OF THE CIRCUIT COURT
ESCAMBIA COUNTY, FLORIDA**

Tax Deed - Redemption Calculator
Account: 031458000 Certificate Number: 001396 of 2008

Redemption Yes Application Date Interest Rate

	Final Redemption Payment ESTIMATED	Redemption Overpayment ACTUAL
	Auction Date <input type="text" value="03/07/2011"/>	Redemption Date <input type="text" value="01/11/2011"/>
Months	6	4
Tax Collector	<input type="text" value="\$2,500.85"/>	<input type="text" value="\$2,500.85"/>
Tax Collector Interest	\$225.08	\$150.05
Tax Collector Fee	<input type="text" value="\$6.25"/>	<input type="text" value="\$6.25"/>
Total Tax Collector	\$2,732.18	\$2,657.15
Clerk Fee	<input type="text" value="\$60.00"/>	<input type="text" value="\$60.00"/>
Sheriff Fee	<input type="text" value="\$120.00"/>	<input type="text" value="\$120.00"/>
Legal Advertisement	<input type="text" value="\$210.00"/>	<input type="text" value="\$210.00"/>
App. Fee Interest	\$35.10	\$23.40
Total Clerk	\$425.10	\$413.40
Postage	<input type="text" value="\$18.00"/>	<input type="text" value="\$18.00"/>
Researcher Copies	<input type="text" value="\$5.00"/>	<input type="text" value="\$5.00"/>
Total Redemption Amount	\$3,180.28	\$3,093.55
	Repayment Overpayment Refund Amount	\$86.73 + 120 + 210 = 416.73

Notes

**Ernie Lee Magaha,
Clerk of the Circuit Court of Escambia County Florida**

Receipt Type **Case** Outstanding Amount **0.00**
Receipt Number **1237501** Receipt Date **01/11/2011**

Case Number **2008 TD 001396**
Description **HEARTWOOD 3 LLC VS**

Action **TAX DEED REDEMPTION**

Judge

Received From **MICHAEL MABIRE**

On Behalf Of **HEARTWOOD 3 LLC**

Total Received	3,180.28
Net Received	3,180.28
Change	0.00

Receipt Payments	Amount	Reference	Description
Cash	3,180.28	CASH	

Receipt Applications	Amount
Holding	3,157.28
Service Charge	23.00

Deputy Clerk: **mavila** Transaction Date **01/11/2011 11:43:55**

Comments

ERNIE LEE MAGAHA
 CLERK OF THE CIRCUIT COURT
 ARCHIVES AND RECORDS
 CHILDSUPPORT
 CIRCUIT CIVIL
 CIRCUIT CRIMINAL
 COUNTY CIVIL
 COUNTY CRIMINAL
 DOMESTIC RELATIONS
 FAMILY LAW
 JURY ASSEMBLY
 JUVENILE
 MENTAL HEALTH
 MIS
 OPERATIONAL SERVICES
 PROBATE
 TRAFFIC



BRANCH OFFICES
ARCHIVES AND RECORDS
JUVENILE DIVISION
CENTURY

CLERK TO THE BOARD OF
 COUNTY COMMISSIONERS
 OFFICIAL RECORDS
 COUNTY TREASURY
 AUDITOR

COUNTY OF ESCAMBIA
OFFICE OF THE
CLERK OF THE CIRCUIT COURT

ERNIE LEE MAGAHA, CLERK OF THE CIRCUIT COURT
Tax Certificate Redeemed From Sale
Account: 031458000 Certificate Number: 001396 of 2008

Payor: MICHAEL MABIRE PO BOX 30664 PENSACOLA, FL 32503 Date 01/11/2011

Clerk's Check #	1	Clerk's Total	\$425.10
Tax Collector Check #	1	Tax Collector's Total	\$2,732.18
		Postage	\$18.00
		Researcher Copies	\$5.00
		Total Received	\$3,180.28

ERNIE LEE MAGAHA
 Clerk of the Circuit Court

Received By: _____
 Deputy Clerk

Escambia County Government Complex • 221 Palafox Place Ste 110 • PENSACOLA, FLORIDA 32502
 (850) 595-3793 • FAX (850) 595-4827 • <http://www.clerk.co.escambia.fl.us>

ERNIE LEE MAGAHA
 CLERK OF THE CIRCUIT COURT
 ARCHIVES AND RECORDS
 CHILDSUPPORT
 CIRCUIT CIVIL
 CIRCUIT CRIMINAL
 COUNTY CIVIL
 COUNTY CRIMINAL
 DOMESTIC RELATIONS
 FAMILY LAW
 JURY ASSEMBLY
 JUVENILE
 MENTAL HEALTH
 MIS
 OPERATIONAL SERVICES
 PROBATE
 TRAFFIC



BRANCH OFFICES
ARCHIVES AND RECORDS
JUVENILE DIVISION
CENTURY

CLERK TO THE BOARD OF
 COUNTY COMMISSIONERS
 OFFICIAL RECORDS
 COUNTY TREASURY
 AUDITOR

COUNTY OF ESCAMBIA
OFFICE OF THE
CLERK OF THE CIRCUIT COURT

Case # 2008 TD 001396
Redeemed Date 01/11/2011

Name MICHAEL MABIRE PO BOX 30664 PENSACOLA, FL 32503

Clerk's Total = TAXDEED	\$425.10
Due Tax Collector = TAXDEED	\$2,732.18
Postage = TD2	\$18.00
ResearcherCopies = TD6	\$5.00

Apply Docket Codes

• For Office Use Only

Date	Docket	Desc	Amount Owed	Amount Due	Payee Name
05/30/2008	TD1	TAX DEED APPLICATION Receipt: 1207477 Date: 10/13/2010	60.00	0.00	
05/30/2008	TAXDEED	TAX DEED CERTIFICATES Receipt: 1207477 Date: 10/13/2010	330.00	0.00	
10/14/2010	TD83	TAX COLLECTOR CERTIFICATION	0.00	0.00	
12/09/2010	TD82	O & E REPORT	0.00	0.00	
01/11/2011	TD6	TITLE RESEARCHER COPY CHARGES	5.00	5.00	
01/11/2011	TD2	POSTAGE TAX DEEDS	18.00	18.00	
01/11/2011	TAXDEED	TAXDEED Due Tax Collector	2,732.18	2,732.18	
01/11/2011	TAXDEED	TAXDEED Clerk's Total	425.10	425.10	

Rcd	Docket Application	Owed	Paid	Dismissed	Due
1	Service Charge	\$83.00	\$60.00	\$0.00	\$23.00
2	Holding	\$3,487.28	\$330.00	\$0.00	\$3,157.28
	TOTAL	\$3,570.28	\$390.00	\$0.00	\$3,180.28

**Ernie Lee Magaha,
Clerk of the Circuit Court of Escambia County Florida**

Receipt Type **Case** Outstanding Amount **0.00**
Receipt Number **1207477** Receipt Date **10/13/2010**

Case Number **2008 TD 001396**
Description **HEARTWOOD 3 LLC VS**

Action **TAX DEED APPLICATION**

Judge

Received From **BANK ATLANTIC**

On Behalf Of **HEARTWOOD 3 LLC**

Total Received	390.00
Net Received	390.00
Change	0.00

Receipt Payments	Amount	Reference	Description
Check	390.00	7030278	

Receipt Applications	Amount
Holding	330.00
Service Charge	60.00

Deputy Clerk: **mavila** Transaction Date **10/13/2010 15:24:16**

Comments



Chris Jones

Escambia County Property Appraiser

Real Estate Search | Tangible Property Search | Amendment 1 Calculations

[Back](#)

Reference
 Account
 Navigate Mode

[Printer Friendly Version](#)

General Information	
Reference:	2715301204000010
Account:	031458000
Owners:	MANN WENDELL
Mail:	4 PACIFIC ST PENSACOLA, FL 32503
Situs:	4 E PACIFIC ST 32503
Use Code:	SINGLE FAMILY RESID
Taxing Authority:	COUNTY MSTU
Tax Inquiry:	Open Tax Inquiry Window
Tax Inquiry link courtesy of Janet Holley, Escambia County Tax Collector	

2010 Certified Roll Assessment	
Improvements:	\$41,907
Land:	\$14,250
Total:	\$56,157
<i>Save Our Homes:</i>	\$56,157
Disclaimer	
Amendment 1 Calculations	

Sales Data					
Sale Date	Book	Page	Value	Type	Official Records (New Window)
06/2007	6164	1158	\$100	OT	View Instr
01/2005	5819	605	\$100	QC	View Instr
10/1985	2172	193	\$100	QC	View Instr
01/1966	294	203	\$12,300	WD	View Instr
Official Records Inquiry courtesy of Ernie Lee Magaha, Escambia County Clerk of the Court					

2010 Certified Roll Exemptions	
HOMESTEAD EXEMPTION	
Legal Description	LT 1 OAKFIELD ESTATES PB 5 P 5 SEC 27/28/38 T 1S R 30 OR 294 P 203 OR 2172 P 193...
Extra Features	FRAME BUILDING METAL BUILDING UTILITY BLDG

[Parcel Information](#)
[Return Map](#)
[Get Map Image](#)
[Launch Interactive Map](#)

Section Map Id: 27-15-30-1
Approx. Acreage: 0.2400
Zoned: R-5

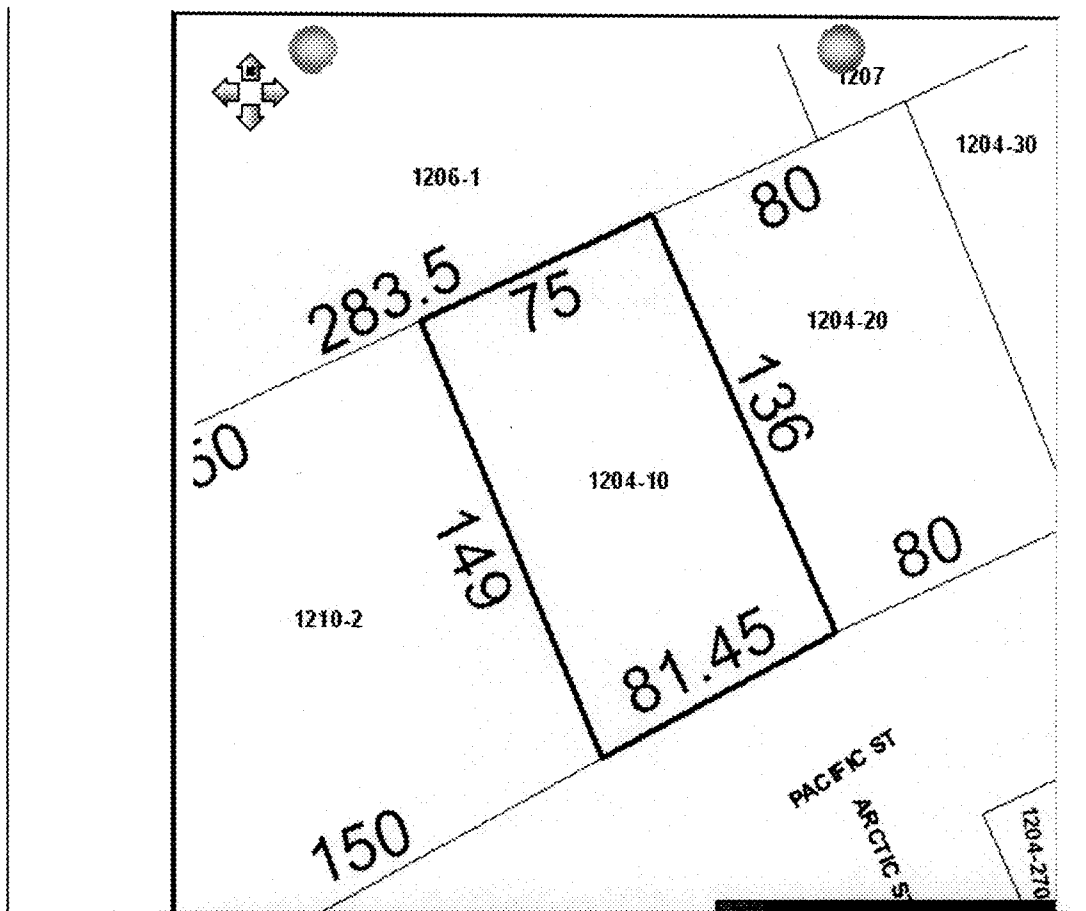

Buildings

Building 1 - Address: 4 E PACIFIC ST, Year Built: 1960, Effective Year: 1960

Structural Elements
FOUNDATION-SLAB ON GRADE
EXTERIOR WALL-CONCRETE BLOCK
NO. PLUMBING FIXTURES-3.00
DWELLING UNITS-1.00
ROOF FRAMING-GABL/HIP COMBO
ROOF COVER-COMPOSITION SHG
INTERIOR WALL-DRYWALL-PLASTER
FLOOR COVER-CARPET
NO. STORIES-1.00
DECOR/MILLWORK-AVERAGE
HEAT/AIR-WALL/FLOOR FURN
STRUCTURAL FRAME-WOOD FRAME

Areas - 2228 Total SF
BASE AREA - 1137
CARPORT UNF - 312
GARAGE FIN - 297
OPEN PORCH FIN - 8
OPEN PORCH UNF - 474

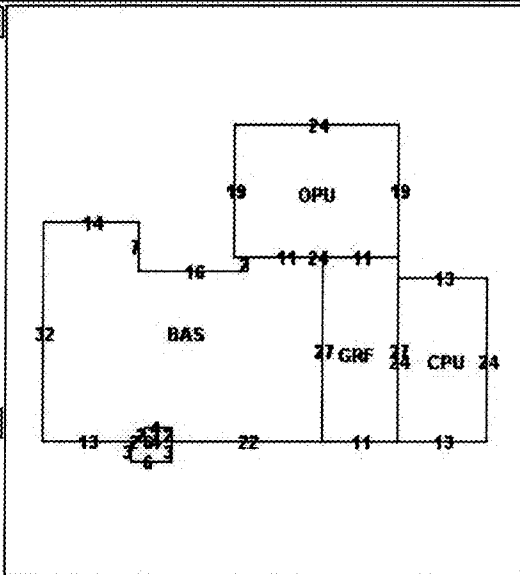

Images

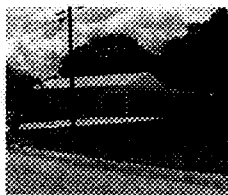

06/19/02



09/15/10

The primary use of the assessment data is for the preparation of the current year tax roll. No responsibility or liability is assumed for inaccuracies or errors.